

NOS PARTENAIRES

Carburier, Porte-outils et plaquette



Fraise carbure - HSS CO



Foret HSS + CW, Alésoir



Taraudage



Accessoire Machine outil



Attachement, Centre, Tour, Etaux



Métrieologie



Divers



Techmo Satech
techmo.fr | satech.fr

Franco de port départ agences - 150 €

Forfait expédition usine - 20 €

Les articles lourds sont indiqués par un logo poids. **KG**
Pour ces articles, des frais de transport supplémentaires sont appliqués.

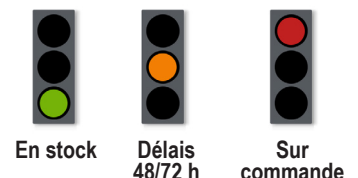

UTILISATION DU COMPTE CLIENT SUR NOTRE SITE INTERNET

www.techmo.fr



www.satech.fr



Accueil | Créer un compte | Me connecter | Actualités



[NOS PRODUITS](#)

Accueil | Mon compte | Actualités



[NOS PRODUITS](#)

Vos informations de connexion

Nom de connexion | IDENTIFIANTS
Adresse courriel | ADRESSE E-MAIL RATTACHÉE AU COMPTE

***POSSIBILITÉ DE CHANGER LE MOT DE PASSE APRÈS CRÉATION DU COMPTE SI CELUI-CI EST OUVERT PAR NOS SOINS**

Modifier

Vos paniers mémorisés

Page 1 sur 1 | Aucune donnée

Nom du panier

Aucune donnée disponible ...

Vos devis en cours

No document	Ref Client	Date
DV2023006794		6 sept. 2023
DV2023006504		25 août 2023
DV2023005094		22 juin 2023
DV2023004711		9 juin 2023
DV2022006488		12 sept. 2022

Page 1 sur 11 | 1 - 5 de 53

Vos commandes en cours

No document	Ref Client	Date
CV2023009306	CDE	4 oct. 2023
CV2023006329	CDE	4 juil. 2023
CV2023001714	CDE TEL	21 févr. 2023
CV2022010091	CDE	26 oct. 2022
CV2022008153	CDE TEL	8 sept. 2022
CV2022007914	CDE	1 sept. 2022

Page 1 sur 1 | 1 - 6 de 6

Vos commandes archivées

No document	Ref Client	Date
CV2023009306	CDE	4 oct. 2023
CV2023009306	CDE	4 oct. 2023
CV2023006329	CDE TEL	4 juil. 2023
CV2023006329	CDE	3 juil. 2023
CV2023006329	CDE TEL	28 juin 2023

Page 1 sur 1 | 1 - 5 de 5



VOTRE RECHERCHE : Code article Techmo-Satech

ou Désignation ou REF fournisseur

Rechercher par code article TECHMO/SATECH
(Exemple : 366095)

Rechercher par désignation article ou
référence fournisseur (Exemple : CNMG120408) →
puis choisir le fournisseur souhaité

ou CNMG120408

Fournisseurs disponibles:

- EINES CANELA S.L. [850080]
- KENAMETAL-HERTEL FRANCE SA [956700]
- KORLOY EUROPE GmbH [850103]
- MITSUBISHI CARBIDE [973700]
- SCHWARZ GmbH Vollhartmetall Präzisions [850133]
- SUMITOMO [993340]
- TUNGALOY FRANCE S.A.S. [995100]

MÉMO

IDENTIFIANT :

LOGIN :

FRAISAGE

FRAISES CARBURE	6
FRAISES HSS	25
FRAISES À CHANFREINER	26
FRAISES SCIES	28

PERÇAGE

FORETS CARBURE	30
ALESAGE	38
FORETS HSS HSS CO	39
FORETS À PLAQUETTES FORETS À POINTER	40

TARAUDAGE

TARAUDS MACHINE VERGNANO	41
TARAUDS MACHINE BASS	44
BRAS DE TARAUDAGE PNEUMATIQUE ÉLECTRIQUE	48

TOURNAGE

PORTE-OUTILS INTÉRIEUR EXTÉRIEUR	48
PLAQUETTES FRAISAGE FILETAGE TOURNAGE	56

DIVERS | MACHINES

OUTILS DE RÉPARATION FILETAGE	60
MÉTROLOGIE	61
AFFÛTEUSE DE FORETS	62
COLONNES DE MESURE	62
STATION DE FRETTAGE	63
MACHINES TRADITIONNELLES	64

ATTACHEMENTS

PINCES	65
MANDRINS HYDRAULIQUES	69
MANDRINS PORTE-PINCES PORTE-FRAISES	70
MANDRINS WELDON	73
MANDRINS DE FRETTAGE	76
ATTACHEMENT COOLCAP	78
FILTRES POUR MACHINES	80

PRISE PIÈCES

ÉTAUX MÉTRIQUES ÉTAUX DE PRÉCISION	81
KIT ACCESSOIRES TOURNEVIS	83

ABRASIF

POLISSAGE	84
BROSSES EXPANSIBLES	85
MACHINE DE MARQUAGE	86
PLATEAU À DÉPRESSION	88
OUTILS DE BROCHAGE	89
PORTE-OUTILS VDI	90
TAMPONS ET BAGUES	93

SLOTWORX® VF

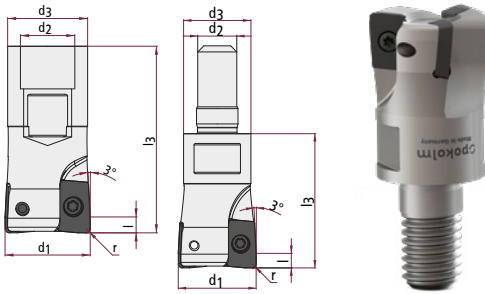

La nouvelle SLOTWORX® VF est une fraise spécialement conçue pour la finition. Grâce à la géométrie spéciale de la plaquette indexable, l'outil peut être utilisé pour la finition des parois et des faces. Le siège de plaquette robuste encastré dans la fraise garantit une grande précision de la plaquette indexable et un fonctionnement régulier de l'outil.

- Finition des surfaces murales ou frontales
- Nombre élevé de dents pour une plus grande avance
- Disponible en version vissée ou interface de connexion DuoPlug®
- Le rayon d'angle R0.8 de la plaquette réduit la pression de coupe

	Catalogue no.	d ₁	l	r	l ₃	l ₂	l ₁	d ₂	d ₃	z	Accessories	Features
Screw-in type	VF09-016-E08-02	16	9.52	0.8	27.5	-	-	M 8	13.8	2	A, B, C, D, E	
	VF09-020-E10-03	20	9.52	0.8	27.5	-	-	M 10	18	3	A, B, C, D, E	
	VF09-025-E12-04	25	9.52	0.8	32.5	-	-	M 12	21	4	A, B, C, D, E	
	VF09-032-E16-05	32	9.52	0.8	32.5	-	-	M 16	29	5	A, B, C, D, E	
	VF09-035-E16-06	35	9.52	0.8	32.5	-	-	M 16	29	6	A, B, C, D, E	
	VF09-042-E16-07	42	9.52	0.8	32.5	-	-	M 16	29	7	A, B, C, D, E	
DuoPlug®	VF09-016-D10-02	16	9.52	0.8	35	-	-	M 10	15	2	A, B, C, D, E	
	VF09-020-D12-03	20	9.52	0.8	37.5	-	-	M 12	18.6	3	A, B, C, D, E	
	VF09-025-D16-04	25	9.52	0.8	42	-	-	M 16	23.5	4	A, B, C, D, E	
Indexable inserts	Catalogue no.	DIN description		Carbide Grade	Coating	l/d	s	r	Torx-screw			
	VF09-8035-R08-LH-2	BPHX 090308 PER-1.5		HSC 05	PPTi	9.52	2.38	0.8	M 2.5			

Milling cutter:	VF09-025-E12-04
D _c :	25 mm
Cooling:	air outside
Indexable insert:	VF09-8035-R08-LH-2
V _c (speed):	400 m/min
n (revolutions):	6366 min ⁻¹
f _t (feed per tooth):	0,25 mm
V _f (feed rate):	4775 mm/min
a _p (depth of cut):	0,5 mm
a _e (width of cut):	0,3 mm
Milling cutter:	VF09-025-E12-04
D _c :	25 mm
Cooling:	air outside
Indexable insert:	VF09-8035-R08-LH-2
V _c (speed):	400 m/min
n (revolutions):	5093 min ⁻¹
f _t (feed per tooth):	0,25 mm
V _f (feed rate):	5093 mm/min
a _p (depth of cut):	1 mm
a _e (width of cut):	1,5 mm

SPINWORX®



- Utilisation à 100 % de l'arête de coupe totale
- Temps d'installation minimisés puisqu'aucune indexation manuelle des inserts n'est nécessaire
- Le volume de copeaux est beaucoup plus élevé sans interruption du processus de production
- Convient pour l'usinage de l'acier, de la fonte, de l'acier inoxydable et des superalliages résistants à la chaleur
- Idéal pour l'ébauche et l'usinage de la matière résiduelle lors du surfacage, du rainurage, du fraisage périphérique et de poche
- Faible consommation d'énergie de la broche de la machine grâce à la formation de copeaux



Matière	INCONEL 718	Matière	TA 6 V	Matière	40 CMD 8	Matière	35 NCD16
Fraise	DR12 032 E 16 04	Fraise	DR12-050-A22-07	Fraise	DR10-025-E12-04	Fraise	DR16-080-A27-07
Diamètre nominal	32mm	Diamètre nominal	50 mm	Diamètre nominal	25 mm	Diamètre nominal	80 mm
Attachement	SK 40	Attachement	SK 40	Attachement	BT 40	Attachement	SK50
Porte à faux	85 mm	Porte à faux	approx. 100 mm	Porte à faux	approx. 80 mm	Porte à faux	165mm
Lubrification	Huile soluble à 10%	Lubrification	Huile soluble à 8%	Lubrification	Air centre broche	Lubrification	Air centre broche
Plaquette	DR12 8 B7	Plaquette	DR12-8B7	Plaquette	DR10 8 F4	Plaquette	DR16 8 F4
V _c	45 m/min	V _c	50m/min	V _c	180 m/min	V _c	200 m/min
N	448 tr /min	N	318 tr/min	N	2291tr/min	N	796 min-1
Fz	0,2mm/dt	Fz	0,19mm/dt	Fz	0,5 mm/dt	Fz	1 mm
Vf	358mm/min	Vf	423 mm/min	Vf	4584 mm/min	Vf	5570 mm/min
Ap	1mm	Ap	1,7mm	Ap	0,7 mm	Ap	2,5 mm
Ae	16mm	Ae	35 mm	Ae	15 mm	Ae	32 mm
Durée de vie	3,6 h	Durée de vie	10 h	Durée de vie	8,2 h	Durée de vie	11,3 h
Volume copeaux	5,73 cm ³ /min	Volume copeaux	29,63 cm ³ /min	Volume copeaux	48,13 cm ³ /min	Volume copeaux	445,63 cm ³ /min

FRAISES CARBURE | FRAISE À USINAGE INOX - TITANE

Articles 288... / 289... / 266...

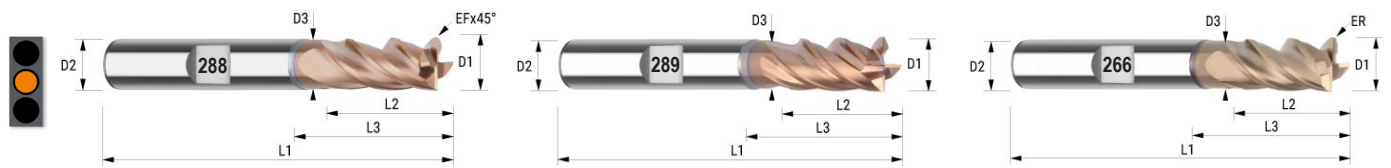

288 / 289 INOX

266 TITANE | INCONEL

D1	D2	L2	L1	D3	L3	EF	Z	Référence	Code HA	Prix promo € net HT	Code HB	Prix promo € net HT	ER	Référence	Code HA	Prix promo € net HT	Code HB	Prix promo € net HT
3,00	6,00	8	57	-	-	0,06	4	288.031...	364341	33,16	363763	33,93	0,10	266.031...	364442	44,02	364451	45,26
4,00	6,00	11	57	-	-	0,08	4	288.041...	364342	33,16	363764	33,93	0,10	266.041...	364443	44,02	364452	45,26
5,00	6,00	13	57	-	-	0,10	4	288.051...	364343	33,16	363765	33,93	0,10	266.051...	364444	44,02	364453	45,26
6,00	6,00	13	57	5,50	21	-	4	289.060...	364349	36,66	363757	37,50	0,10	266.060...	364445	44,02	364454	45,26
8,00	8,00	19	63	7,50	27	-	4	289.080...	364350	48,79	363758	49,62	0,20	266.080...	364446	55,43	364455	56,67
10,00	10,00	22	72	9,50	32	-	4	289.100...	364351	68,34	363759	69,60	0,20	266.100...	364447	72,31	364456	73,97
12,00	12,00	26	83	11,50	38	-	4	289.120...	364352	89,85	363760	91,11	0,20	266.120...	364448	99,48	364457	101,14
16,00	16,00	32	92	15,50	44	-	4	289.160...	364353	158,87	363761	160,61	0,30	266.160...	364449	150,47	364458	152,71
20,00	20,00	38	104	19,50	54	-	4	289.200...	364354	216,54	363762	218,64	0,30	266.200...	364450	219,30	364459	222,00

FRAISES CARBURE | HELICE VARIABLE 4Z INOX



INCONEL | TITANE | INOX

Articles 1.393 ...

SÉRIE NORMALE - DÉGAGEMENT ARRIÈRE - RAYONNÉE

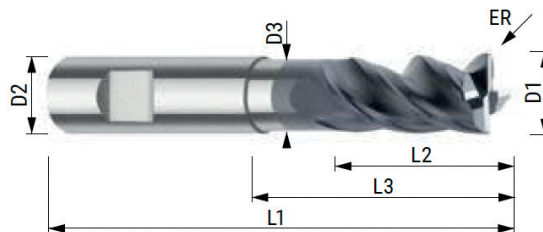

D1	D2	L2	L1	D3	L3	ER	Z	Articles	Code	Prix promo € net HT	D1	D2	L2	L1	D3	L3	ER	Z	Articles	Code	Prix promo € net HT	
8,00	8,00	19	63	7,5	27	0,5	4	1.393.081.10	366905	32,17	12,00	12,00	26	83	11,5	38	4,0	4	1.393.127.10	366925	59,64	
8,00	8,00	19	63	7,5	27	1,0	4	1.393.082.10	366906	32,17	16,00	16,00	32	92	15,5	44	0,5	4	1.393.161.10	366927	90,78	
8,00	8,00	19	63	7,5	27	1,5	4	1.393.083.10	366907	32,17	16,00	16,00	32	92	15,5	44	1,0	4	1.393.162.10	366928	90,78	
8,00	8,00	19	63	7,5	27	2,0	4	1.393.084.10	366908	32,17	16,00	16,00	32	92	15,5	44	1,5	4	1.393.163.10	366929	90,78	
8,00	8,00	19	63	7,5	27	2,5	4	1.393.085.10	366909	32,17	16,00	16,00	32	92	15,5	44	2,0	4	1.393.164.10	366930	90,78	
10,00	10,00	22	72	9,5	32	0,5	4	1.393.101.10	366911	44,05	16,00	16,00	32	92	15,5	44	2,5	4	1.393.164.10	366931	90,78	
10,00	10,00	22	72	9,5	32	1,0	4	1.393.102.10	366912	44,05	16,00	16,00	32	92	15,5	44	3,0	4	1.393.166.10	366932	90,78	
10,00	10,00	22	72	9,5	32	1,5	4	1.393.103.10	366913	44,05	16,00	16,00	32	92	15,5	44	4,0	4	1.393.167.10	366933	90,78	
10,00	10,00	22	72	9,5	32	2,0	4	1.393.104.10	366914	44,05	20,00	20,00	38	104	19,5	54	0,5	4	1.393.201.10	366935	133,16	
10,00	10,00	22	72	9,5	32	2,5	4	1.393.105.10	366915	44,05	20,00	20,00	38	104	19,5	54	1,0	4	1.393.202.10	366936	133,16	
10,00	10,00	22	72	9,5	32	3,0	4	1.393.106.10	366916	44,05	20,00	20,00	38	104	19,5	54	1,5	4	1.393.203.10	366937	133,16	
10,00	10,00	22	72	9,5	32	4,0	4	1.393.107.10	366917	44,05	20,00	20,00	38	104	19,5	54	2,0	4	1.393.204.10	366938	133,16	
12,00	12,00	26	83	11,5	38	0,5	4	1.393.121.10	366919	59,64	20,00	20,00	38	104	19,5	54	2,5	4	1.393.205.10	366939	133,16	
12,00	12,00	26	83	11,5	38	1,0	4	1.393.122.10	366920	59,64	20,00	20,00	38	104	19,5	54	3,0	4	1.393.206.10	366940	133,16	
12,00	12,00	26	83	11,5	38	1,5	4	1.393.123.10	366921	59,64	20,00	20,00	38	104	19,5	54	4,0	4	1.393.207.10	366941	133,16	
12,00	12,00	26	83	11,5	38	2,0	4	1.393.124.10	366922	59,64												
12,00	12,00	26	83	11,5	38	2,5	4	1.393.125.10	366923	59,64												
12,00	12,00	26	83	11,5	38	3,0	4	1.393.126.10	366924	59,64												

FRAISES CARBURE | HELICE VARIABLE 4Z INOX



INCONEL | TITANE | INOX



Articles 1.389 ...

SÉRIE NORMALE

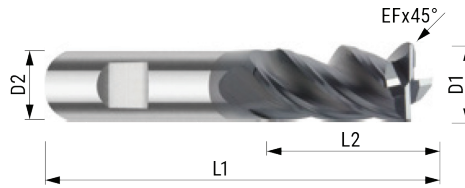

D1	D2 H6	L2	L1	EF	Z	Articles	Code	Prix promo € net HT
6,00	6,00	13	57	0,20	4	1.389.060.10	366082	16,91
8,00	8,00	19	63	0,20	4	1.389.080.10	366083	22,05
10,00	10,00	22	72	0,20	4	1.389.100.10	366084	32,40
12,00	12,00	26	83	0,30	4	1.389.120.10	366085	44,31
16,00	16,00	32	92	0,30	4	1.389.160.10	366086	69,73
20,00	20,00	38	104	0,40	4	1.389.200.10	366087	107,99

| DANS LA LIMITE DES STOCKS DISPONIBLES |

Articles 1.390 ...

SÉRIE NORMALE - DÉGAGEMENT ARRIÈRE

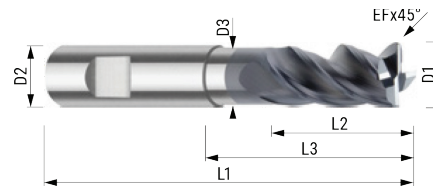

D1	D2	L2	L1	D3	L3	EF	Z	Articles	HA	HB	Code		Prix promo € net HT
											HA	HB	
3,00	6,00	8	57	2,75	18	0,10	4	1.390.03000	.10	366330	366901	21,59
4,00	6,00	11	57	3,50	21	0,13	4	1.390.04000	.10	366331	366902	21,59
5,00	6,00	13	57	4,50	21	0,20	4	1.390.05000	.10	366332	366903	21,59
6,00	6,00	13	57	5,50	21	0,20	4	1.390.06000	.10	366333	366090	21,59
8,00	8,00	19	63	7,50	27	0,20	4	1.390.08000	.10	366334	366091	29,25
10,00	10,00	22	72	9,50	32	0,20	4	1.390.10000	.10	366335	366092	40,17
12,00	12,00	26	83	11,50	38	0,30	4	1.390.12000	.10	366336	366093	55,14
16,00	16,00	32	92	15,50	44	0,30	4	1.390.16000	.10	366337	366094	84,52
20,00	20,00	38	104	19,50	54	0,40	4	1.390.20000	.10	366338	366095	125,27

Articles 1.388...

SÉRIE EXTRA COURTE

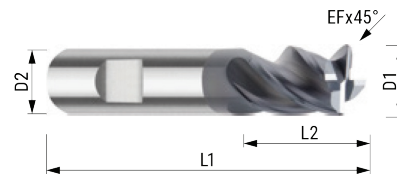

D1	D2 H6	L2	L1	EF	Z	Articles	Code	Prix promo € net HT
3,00	6,00	6	54	0,10	4	1.388.030.10	366058	18,39
4,00	6,00	8	54	0,13	4	1.388.040.10	366059	18,39
5,00	6,00	9	54	0,18	4	1.388.050.10	366060	18,39
6,00	6,00	10	54	0,20	4	1.388.060.10	366052	18,39
8,00	8,00	12	58	0,20	4	1.388.080.10	366053	22,58
10,00	10,00	14	66	0,20	4	1.388.100.10	366054	31,71
12,00	12,00	16	73	0,30	4	1.388.120.10	366055	37,31
16,00	16,00	22	82	0,30	4	1.388.160.10	366056	76,53
20,00	20,00	26	92	0,40	4	1.388.200.10	366057	114,69

FRAISES CARBURE | HELICE VARIABLE 4Z INOX

InovaTools
GERMAN TOOLS GROUP

TITANE | INOX

Articles 1.392 ...

SÉRIE NORMALE - BEC VIF

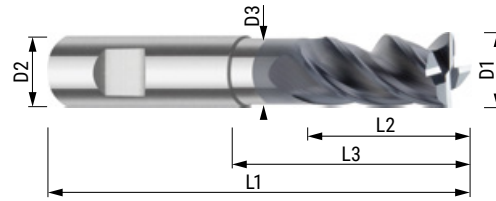

D1	D2 H6	L2	L1	D3	L3	Z	Articles	Code	Prix promo € net HT
3,00	6,00	8	57	2,75	18	4	1.392.030.10	366021	22,58
4,00	6,00	11	57	3,50	21	4	1.392.040.10	366022	22,58
5,00	6,00	13	57	4,50	21	4	1.392.050.10	366023	22,58
6,00	6,00	13	57	5,50	21	4	1.392.060.10	366024	22,58
8,00	8,00	19	63	7,50	27	4	1.392.080.10	366025	30,24
10,00	10,00	22	78	9,50	32	4	1.392.100.10	366026	41,67
12,00	12,00	26	83	11,50	38	4	1.392.120.10	366027	56,64
16,00	16,00	32	92	15,50	44	4	1.392.160.10	366028	86,60
20,00	20,00	38	104	19,50	54	4	1.392.200.10	366029	127,77

FRAISES CARBURE | HELICE VARIABLE 3Z INOX

InovaTools
GERMAN TOOLS GROUP

INOX

Articles 1.391 ...

SÉRIE NORMALE

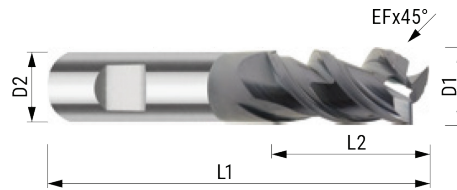

D1	D2 H6	L2	L1	EF	Z	Articles	Code	Prix promo € net HT
3,00	6,00	8	57	0,05	3	1.391.030.10	366134	25,17
4,00	6,00	11	57	0,05	3	1.391.040.10	366135	25,17
5,00	6,00	13	57	0,08	3	1.391.050.10	366136	22,59
6,00	6,00	13	57	0,08	3	1.391.060.10	366137	25,17
7,00	8,00	16	63	0,08	3	1.391.070.10	366138	33,75
8,00	8,00	19	63	0,10	3	1.391.080.10	366139	33,75
9,00	10,00	19	72	0,10	3	1.391.090.10	366140	34,25
10,00	10,00	22	72	0,10	3	1.391.100.10	366141	47,14
12,00	12,00	26	83	0,15	3	1.391.120.10	366142	68,01
16,00	16,00	32	92	0,20	3	1.391.160.10	366143	104,73
20,00	20,00	38	104	0,20	3	1.391.200.10	366144	167,84

FRAISES CARBURE | FRAISES A CHANFREINER 60° / 90°



TITANE | INOX | ACIER | FONTE

Articles 1.795 ... / 760

SÉRIE NORMALE

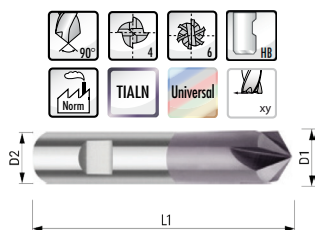

D1	D2 H6	L1	Z	Articles	Z	Code	Prix promo € net HT	Articles	Z	Code	Prix promo € net HT
4,00	4,00	54	4	1.795.040.10	4	366176	16,68	760.040.00	4	363777	21,14
6,00	6,00	57	4	1.795.060.10	4	366177	21,49	760.060.00	4	363778	26,18
8,00	8,00	63	4	1.795.080.10	4	366178	27,85	760.080.00	5	363779	34,24
10,00	10,00	72	4	1.795.100.10	4	366179	32,31	760.100.00	6	363780	39,27
12,00	12,00	83	4	1.795.120.10	4	366180	47,41	760.120.00	6	363781	58,41
16,00	16,00	92	4	1.795.160.10	4	366181	80,36	760.160.00	6	363782	99,68
20,00	20,00	104	4	1.795.200.10	4	366182	121,16	760.200.00	6	363783	151,05

FRAISES CARBURE | FRAISES POUR USINAGE DYNAMIQUE 5Z



ACIER

Articles 591 ...

DEUX TAILLES CARBURE MONOBLOC ACIER
POUR FRAISAGE TROCHOÏDAL



D1	D2	L2	L1	D3	L3	EF	Z	Articles	HA	HB	Code		Prix promo € net HT
											HA	HB	
6,00	6,00	18	62	5,80	25	0,10	5	591.06000	.10	364367	364418	35,31
8,00	8,00	24	68	7,80	30	0,15	5	591.08000	.10	364368	364419	48,33
10,00	10,00	30	80	9,80	35	0,20	5	591.10000	.10	364369	364420	64,63
12,00	12,00	36	93	11,80	45	0,20	5	591.12000	.10	364370	364421	84,19
16,00	16,00	48	108	15,80	55	0,30	5	591.16000	.10	364371	364422	130,34
20,00	20,00	60	126	19,80	70	0,40	5	591.20000	.10	364372	364423	209,10



INOX | ACIER

Articles 592 ...

DEUX TAILLES CARBURE MONOBLOC INOX
POUR FRAISAGE TROCHOÏDAL



D1	D2	L2	L1	D3	L3	EF	Z	Articles	HA	HB	Code		Prix promo € net HT
											HA	HB	
6,00	6,00	18	62	5,80	25	0,10	5	592.06000	.10	364373	364424	42,91
8,00	8,00	24	68	7,80	30	0,15	5	592.08000	.10	364374	364425	55,40
10,00	10,00	30	80	9,80	35	0,20	5	592.10000	.10	364375	364426	71,69
12,00	12,00	36	93	11,80	45	0,20	5	592.12000	.10	364376	364427	89,61
16,00	16,00	48	108	15,80	55	0,30	5	592.16000	.10	364377	364428	146,64
20,00	20,00	60	126	19,80	70	0,40	5	592.20000	.10	364378	364429	228,12

Articles 593 ...

FRAISES CARBURE MONOBLOC TITANE
POUR FRAISAGE TROCHOÏDAL

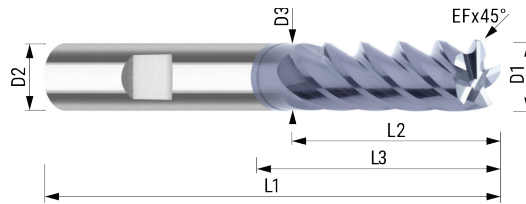

D1	D2 H6	L2	L1	D3	L3	EF	Z	Articles	Code	Prix promo € net HT
6,00	6,00	18	62	5,80	25	0,10	5	593.060.10	363910	49,57
8,00	8,00	24	68	7,80	30	0,15	5	593.080.10	363911	63,16
10,00	10,00	30	80	9,80	35	0,20	5	593.100.10	363912	79,80
12,00	12,00	36	93	11,80	45	0,20	5	593.120.10	363913	101,53
16,00	16,00	48	108	15,80	55	0,30	5	593.160.10	363914	163,84
20,00	20,00	60	126	19,80	70	0,40	5	593.200.10	363915	246,15

Articles 595 ...

FRAISE DYNAMIQUE DEUX TAILLES
CARBURE MONOBLOC

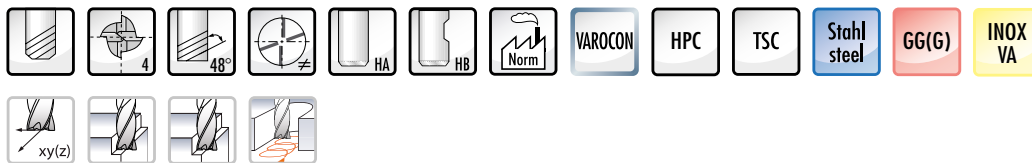
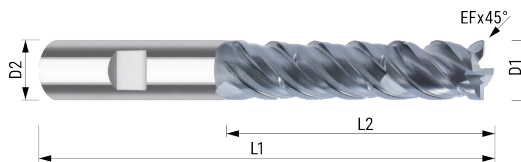

D1	D2 H6	L2	L1	EF	Z	Articles	HA	HB	Code		Prix promo € net HT
									HA	HB	
6,00	6,00	14	54	0,08	4	595.06000	.10	363950	363962	36,66
6,00	6,00	23	80	0,08	4	595.06300	.10	363951	363963	54,64
8,00	8,00	18	60	0,10	4	595.08000	.10	363952	363964	55,63
8,00	8,00	32	100	0,10	4	595.08300	.10	363953	363965	71,17
10,00	10,00	22	70	0,10	4	595.10000	.10	363954	363966	68,43
10,00	10,00	40	100	0,10	4	595.10300	.10	363955	363967	96,34
12,00	12,00	23	83	0,15	4	595.12000	.10	363956	363968	93,84
12,00	12,00	45	110	0,15	4	595.12300	.10	363957	363969	124,82
16,00	16,00	34	92	0,20	4	595.16000	.10	363958	363970	165,22
16,00	16,00	55	150	0,20	4	595.16300	.10	363959	363971	194,90
20,00	20,00	42	104	0,25	4	595.20000	.10	363960	363972	243,42
20,00	20,00	65	150	0,25	4	595.20300	.10	363961	363973	294,54

FRAISES CARBURE | FRAISE HPC INOX 3xD

InovaTools
GERMAN TOOLS GROUP

INOX

Articles 1395 ...

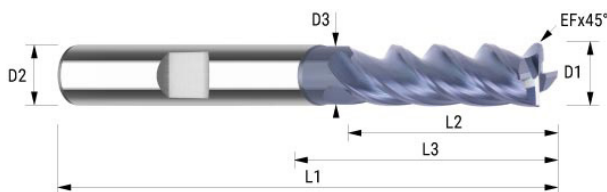

D1	D2	L2	L1	D3	L3	EF	Z	Articles	Code	Prix promo € net HT
6,00	6,00	22	63	5,50	30	0,20	4,00	139506010	3630115	28,71
8,00	8,00	28	80	7,50	36	0,20	4,00	139508010	3630116	34,28
10,00	10,00	33	100	9,50	54	0,20	4,00	139510010	3630117	52,42
12,00	12,00	42	100	11,50	54	0,30	4,00	139512010	3630118	64,20
14,00	14,00	48	100	13,50	54	0,30	4,00	139514010	3630119	92,31
16,00	16,00	53	150	15,50	69	0,30	4,00	139516010	3630120	125,71
18,00	18,00	65	150	17,50	84	0,40	4,00	139518010	3630121	166,54
20,00	20,00	68	150	19,50	84	0,40	4,00	139520010	3630122	193,44

FRAISES CARBURE | FRAISE À COPIER INO-SPEED 4Z

InovaTools
GERMAN TOOLS GROUP

ACIER

Articles 338 ...

FRAISE À COPIER GRANDE AVANCE
CARBURE MONOBLOC TORIQUE INO-SPEED

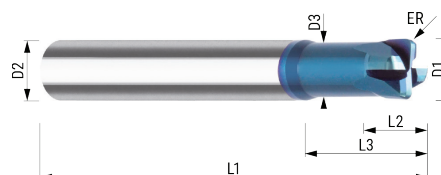

D1	D2 H6	L2	L1	D3	L3	ER	Z	Articles	Code	Prix promo € net HT
2,00	6,00	1,50	50	1,90	6	0,50	4	338.020.05	364379	37,20
3,00	6,00	2,00	50	2,80	8	0,50	4	338.030.05	364380	37,20
4,00	6,00	4,50	50	3,80	20	0,50	4	338.040.05	364381	37,20
5,00	6,00	2,00	60	4,80	10	0,50	4	338.050.05	364382	37,20
6,00	6,00	2,50	75	5,40	25	0,50	4	338.060.05	364383	37,20
6,00	6,00	2,50	60	5,40	30	1,00	4	338.060.10	364384	37,20
8,00	8,00	3,50	75	7,60	40	1,00	4	338.080.10	364385	58,30
10,00	10,00	4,00	70	9,00	45	1,00	4	339.100.10	364386	72,87
10,00	10,00	4,00	70	9,00	45	2,00	4	338.100.20	364387	72,87
12,00	12,00	5,00	100	11,00	62	1,00	4	338.120.10	364388	105,20
12,00	12,00	5,00	80	11,00	45	2,00	4	338.120.20	364389	97,15
12,00	12,00	5,00	100	11,00	62	2,00	4	338.121.20	364390	105,20
16,00	16,00	7,00	120	15,00	70	1,00	4	338.160.10	364391	137,13
16,00	6,00	7,00	120	15,00	70	2,00	4	338.160.20	364392	137,13
20,00	20,00	8,00	130	19,00	75	2,00	4	338.200.20	364393	200,42
20,00	20,00	8,00	130	19,00	75	3,00	4	338.200.30	364394	200,42

FRAISES CARBURE | FRAISE HPC UNI 3xD

InovaTools
GERMAN TOOLS GROUP

ACIER | FONTE

Articles 1.724...

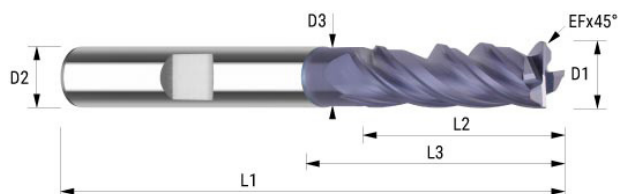

D1	D2	L2	L1	D3	L3	EF	Z	Articles	Code	Prix promo € net HT
6,00	6,00	22	63	5,50	30	0,20	4	172406010	366272	31,56
8,00	8,00	28	80	7,50	36	0,20	4	172408010	366273	38,76
10,00	10,00	33	100	9,50	54	0,20	4	172410010	366274	50,66
12,00	12,00	42	100	11,50	54	0,30	4	172412010	366275	65,03
16,00	16,00	53	150	15,50	69	0,30	4	172416010	366276	117,15
20,00	20,00	68	150	19,50	84	0,40	4	172420010	366277	170,31

FRAISES CARBURE | HELICE VARIABLE 3Z UNIVERSELLE

InovaTools
GERMAN TOOLS GROUP

INOX | ACIER | FONTE

Articles 1.929 ...

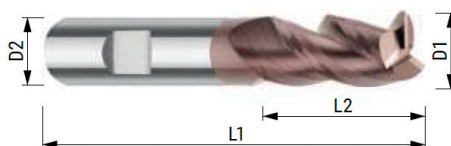

SÉRIE NORMALE



D1	D2	L2	L1	EF	Z	Articles	Code	Prix promo € net HT
3,00	6,00	8	57	0,10	3	1.929.030.10	366185	12,17
4,00	6,00	11	57	0,10	3	1.929.040.10	366186	11,46
5,00	6,00	13	57	0,15	3	1.929.050.10	366187	17,58
6,00	6,00	13	57	0,20	3	1.929.060.10	366188	18,32
8,00	8,00	19	63	0,20	3	1.929.080.10	366189	24,84
10,00	10,00	22	72	0,20	3	1.929.100.10	366190	32,62
12,00	12,00	26	83	0,30	3	1.929.120.10	366191	37,04
16,00	16,00	32	92	0,30	3	1.929.160.10	366192	51,98
20,00	20,00	38	104	0,40	3	1.929.200.10	366193	80,34

Le saviez-vous ?

InovaTools
GERMAN TOOLS GROUP



Usinage haute performance des aciers au chrome et superalliages



Usinage haute performance d'Inox/ aciers alliés (forte résistance à l'oxydation, propre dureté et dureté thermique)



Usinage HSC et dur (forte teneur en aluminium, réfractaire et résistant à l'oxydation)



Revêtement standard universel pour ébauche et finition



Usinage haute performance / usinage dur (couche nano-composite avec haute résistance à la chaleur et à l'oxydation)



Alliages d'Aluminium et Titane (mono-couche pour réduire les arêtes rapportées)

FRAISES CARBURE | HELICE VARIABLE 4Z UNIVERSELLE



INOX | ACIER | FONTE

Articles 1.741...

SÉRIE EXTRA COURTE

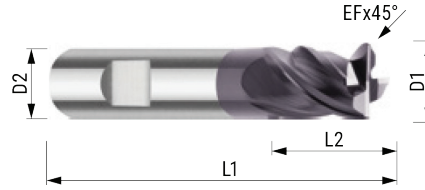

D1	D2 H6	L2	L1	EF	Z	Articles	Code	Prix promo € net HT
3,00	6,00	6	54	0,10	4	1.741.030.10	366243	13,67
4,00	6,00	8	54	0,13	4	1.741.040.10	366244	13,67
5,00	6,00	9	54	0,18	4	1.741.050.10	366245	13,67
6,00	6,00	10	54	0,20	4	1.741.060.10	366246	13,67
8,00	8,00	12	58	0,20	4	1.741.080.10	366247	17,95
10,00	10,00	14	66	0,20	4	1.741.100.10	366248	24,02
12,00	12,00	16	73	0,30	4	1.741.120.10	366249	32,71
16,00	16,00	22	82	0,30	4	1.741.160.10	366250	55,64
20,00	20,00	26	92	0,40	4	1.741.200.10	366251	81,29

Articles 1.742 ...

SÉRIE NORMALE

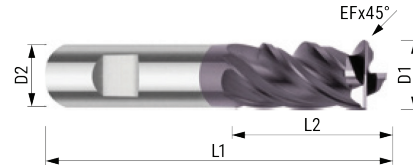

D1	D2 H6	L2	L1	EF	Z	Articles	Code	Prix promo € net HT
6,00	6,00	13	57	0,2	4	1.742.060.10	366255	13,07
8,00	8,00	19	63	0,2	4	1.742.080.10	366256	19,08
10,00	10,00	22	72	0,2	4	1.742.100.10	366257	25,00
12,00	12,00	26	83	0,3	4	1.742.120.10	366258	36,00
16,00	16,00	32	92	0,3	4	1.742.160.10	366259	56,73
20,00	20,00	38	104	0,4	4	1.742.200.10	366260	82,63

| DANS LA LIMITE DES STOCKS DISPONIBLES |

Articles 1.743 ...

SÉRIE NORMALE - DÉGAGEMENT ARRIÈRE

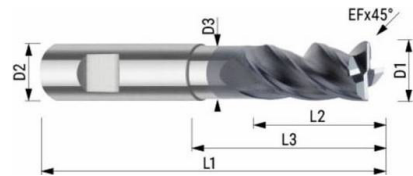

D1	D2	L2	L1	D3	L3	EF	Z	Articles	HA	HB	Code		Prix promo € net HT
											HA	HB	
3,00	6,00	8	57	2,80	18	0,13	4	1.743.03000	.10	366280	366261	17,58
4,00	6,00	11	57	3,60	21	0,13	4	1.743.04000	.10	366281	366262	17,58
5,00	6,00	13	57	4,60	21	0,20	4	1.743.05000	.10	366282	366263	17,58
6,00	6,00	13	57	5,50	21	0,20	4	1.743.06000	.10	366283	366264	17,58
8,00	8,00	19	63	7,50	27	0,20	4	1.743.08000	.10	366284	366265	24,74
10,00	10,00	22	72	9,50	32	0,20	4	1.743.10000	.10	366285	366266	30,77
12,00	12,00	26	83	11,50	38	0,30	4	1.743.12000	.10	366286	366267	42,86
16,00	16,00	32	92	15,50	44	0,30	4	1.743.16000	.10	366287	366268	65,84
20,00	20,00	38	104	19,50	54	0,40	4	1.743.20000	.10	366288	366269	97,80

FRAISES CARBURE | PAS VARIABLE

Fraise ravageuse

ACIER | INOX | FONTE

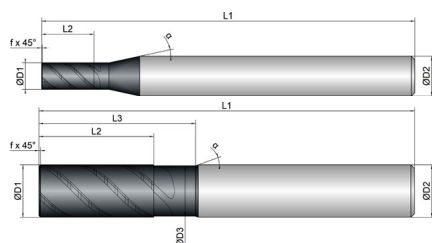
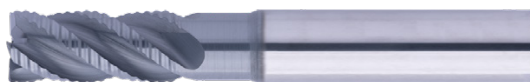
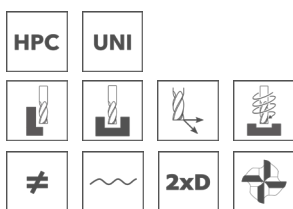

Désignation	D1	D2	L2	L3	L1	Code	HA € net HT	Code	HB € net HT
Fr carb. ravageuse hél. Variable ø 4,0 mm	4.0	6.0	8.0	-	57.0	277001	26,81	277009	26,81
Fr carb. ravageuse hél. Variable ø 5,0 mm	5.0	6.0	9.0	-	57.0	277002	26,81	277010	26,81
Fr carb. ravageuse hél. Variable ø 6,0 mm	6.0	6.0	13.0	19.0	57.0	277003	26,81	277011	26,81
Fr carb. ravageuse hél. Variable ø 8,0 mm	8.0	8.0	19.0	25.0	63.0	277004	34,84	277012	34,84
Fr carb. ravageuse hél. Variable ø 10,0 mm	10.0	10.0	22.0	30.0	72.0	277005	42,24	277013	42,24
Fr carb. ravageuse hél. Variable ø 12,0 mm	12.0	12.0	26.0	36.0	83.0	277006	50,84	277014	50,84
Fr carb. ravageuse hél. Variable ø 16,0 mm	16.0	16.0	31.0	42.0	92.0	277007	89,55	277015	89,55
Fr carb. ravageuse hél. Variable ø 20,0 mm	20.0	20.0	41.0	52.0	104.0	277008	129,83	277016	129,83

FRAISES CARBURE | FRAISE DYNAMIQUE TSC

Articles 600... / 599...

INOX | ACIER | FONTE

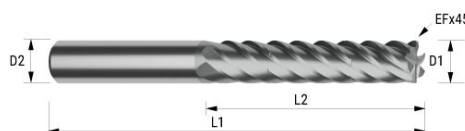
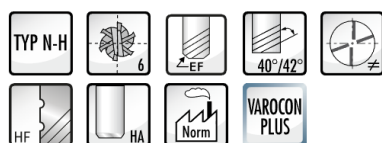

600										599				
D1	D2	EF	F	L2	L1	Articles	Code	Prix promo € net HT	L2	L1	Articles	Code	Prix promo € net HT	
10,00	10,00	0,20	6	50	96	60010000	366421	110,18	40	89	59910000	366425	98,06	
12,00	12,00	0,24	6	60	112	60012000	366422	144,73	48	100	59912000	366426	118,83	
16,00	16,00	0,32	6	80	136	60016000	366423	245,84	64	123	59916000	366427	203,72	
20,00	20,00	0,40	6	100	160	60020000	366424	362,43	80	140	59920000	366428	316,89	

FRAISES CARBURE | SERIE COURTE 3Z

Articles 351...

INOX | ACIER | FONTE

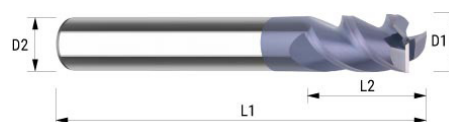

D1h10	D2h6	L2	L1	Z	Référence	Code	Prix promo € net HT
1,00	6	3	50	3	35101000	282286	16,46
1,50	6	4	50	3	35101500	282287	16,46
2,00	6	5	50	3	35102000	282288	16,46
2,50	6	6	50	3	35102500	282289	16,46
3,00	6	7	50	3	35103000	282290	16,46
3,50	6	7	50	3	35103500	282291	16,46
4,00	6	8	50	3	35104000	282292	16,46
4,50	6	9	50	3	35104500	282293	16,46
5,00	6	10	50	3	35105000	282294	16,46
5,50	6	10	50	3	35105500	282295	16,46

FRAISES CARBURE | FRAISE TORIQUE 902

FRAISE 902 TORIQUE

ACIER

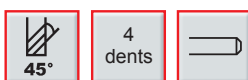

SÉRIE EXTRA LONGUE



D1	D2	HA	L2	L1	Z	R	Code	Prix tarif € net HT
7	6	9	120	4	0,5		363740	86,88
9	8	12	135	4	1		363741	126,12
11	10	15	150	4	1		363742	134,57
13	12	18	160	4	1		363743	193,11
17	16	24	180	4	1,5		363744	321,66

queue réduite

FRAISE 216 - 217

ALUMINIUM

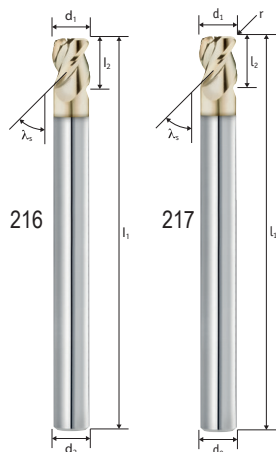

216 45 03C

D1	D2	L2	L1	r	Article	Code	Prix promo € net HT	Article	Code	Prix promo € net HT
7	6	8	125		216 45 03C-070	277072	128,36			
9	8	10	140		216 45 03C-090	277073	171,89			
11	10	13	150		216 45 03C-110	277074	207,06			
13	12	15	150		216 45 03C-130	277075	249,27			
7	6	8	125	1,5				998074244	277076	136,33
9	8	10	140	2				998074246	277077	163,62
11	10	13	150	2				998074248	277078	196,09
13	12	15	150	2,5				998074250	277079	245,12

queue réduite

FRAISES CARBURE | FRAISE TORIQUE

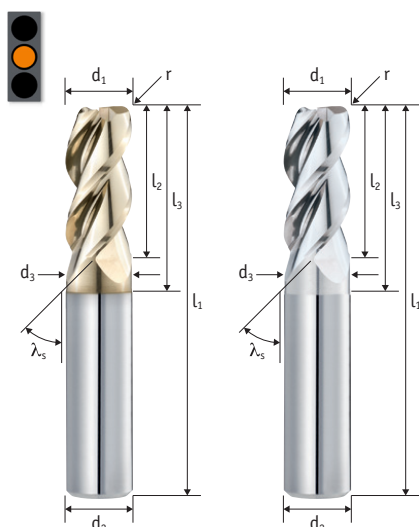

d1	d2	l2	l1	d3	l3	r	Code	Revêtues € promo ht	Non Revêtues Code	€ promo ht
4	6	11	57	3,7	14	0,5	277080	41,96	277111	36,15
4	6	11	57	3,7	14	1	277081	41,96	277112	36,15
5	6	13	57	4,7	16	0,5	277082	41,96	277113	36,15
5	6	13	57	4,7	16	1	277083	41,96	277114	36,15
6	6	13	57	5,7	21	0,5	277084	40,65	277115	35,07
6	6	13	57	5,7	21	1	277085	40,65	277116	35,07
6	6	13	57	5,7	21	2	277086	40,65	277117	35,07
8	8	19	63	7,7	27	0,5	277087	52,18	277118	43,90
8	8	19	63	7,7	27	1	277088	52,18	277119	43,90
8	8	19	63	7,7	27	2	277089	52,18	277120	43,90
10	10	22	72	9,7	32	0,5	277090	68,67	277121	57,91
10	10	22	72	9,7	32	1	277091	68,67	277122	57,91
10	10	22	72	9,7	32	2	277092	68,67	277123	57,91
10	10	22	72	9,7	32	3	277093	68,67	277124	57,91
10	10	22	72	9,7	32	4	277094	68,67	277125	57,91
12	12	26	83	11,7	38	0,5	277095	89,03	277126	74,32
12	12	26	83	11,7	38	1	277096	89,03	277127	74,32
12	12	26	83	11,7	38	2	277097	89,03	277128	74,32
12	12	26	83	11,7	38	3	277098	89,03	277129	74,32
12	12	26	83	11,7	38	4	277099	89,03	277130	74,32
16	16	32	92	15,7	44	0,5	277100	141,06	277131	115,66
16	16	32	92	15,7	44	1	277101	141,06	277132	115,66
16	16	32	92	15,7	44	2	277102	141,06	277133	115,66
16	16	32	92	15,7	44	3	277103	141,06	277134	115,66
16	16	32	92	15,7	44	4	277104	141,06	277135	115,66
20	20	38	104	19,7	54	0,5	277105	217,39	277136	177,21
20	20	38	104	19,7	54	1	277106	217,39	277137	177,21
20	20	38	104	19,7	54	2	277107	217,39	277138	177,21
20	20	38	104	19,7	54	3	277108	217,39	277139	177,21
20	20	38	104	19,7	54	4	277109	217,39	277140	177,21
20	20	38	104	19,7	54	5	277110	217,39	277141	177,21

| DANS LA LIMITE DES STOCKS DISPONIBLES |

FRAISES CARBURE | STANDARD - SÉRIES COURTES 2Z 3Z NORMALE 4Z

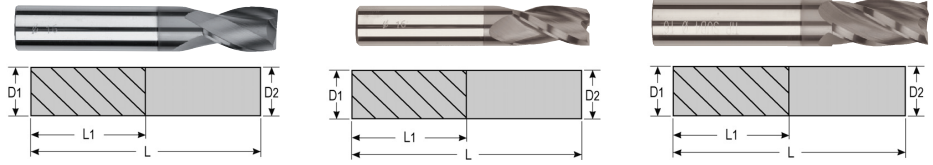

* Jusqu'à épuisement des stocks



		2 dents				3 dents				4 dents				
D1	D2	H6	L1	L	Code	Prix promo € net HT	L1	L	Code	Prix promo € net HT	L1	L	Code	Prix promo € net HT
2	2	6	40		366200	13,81	6	40	366300	14,39	6	40	366400	15,25
2,5	2,5	8	40		366201	9,85 *	10	40	366301*	9,85	10	40	366401*	10,20
3	3	8	40		366202	13,81	10	40	366302	14,07	10	40	366402	15,25
3,5	3,5	8	50		366203	9,85 *	8	50	366303*	14,07	10	50	366403*	14,91
4	4	12	40		366204	12,63	12	40	366304	14,39	11	50	366404	13,95
4,5	4,5	12	40		366209	9,85 *	12	40	366307*	9,85	12	40	366407*	10,20
5	5	14	50		366205	13,68	14	50	366305	16,36	13	50	366405	16,71
5,5	5,5	14	50		366211	10,59*	14	50	366309*	10,59	14	50	366409*	14,55
6	6	16	50		366206	13,68	16	50	366306	17,23	13	57	366406	18,45
6,5	6,5	16	60		366207	11,79*	16	60	366311*	12,92	16	60	366411*	18,13
8	8	20	60		366208	19,31	20	60	366308	23,65	19	63	366408	21,98
10	10	22	70		366210	24,90	22	70	366310*	28,24	22	72	366410	29,62
12	12	22	70		366212*	35,35	22	70	366312	38,57	26	83	366412	41,17
14	14	-	-		-	-	25	75	366314*	67,34	32	92	366414	71,45
16	16	25	75		366216*	71,01	25	75	366316	73,11	32	92	366416	76,27
18	18	26	92		366218*	85,10	32	100	366318*	83,41	38	100	366418	89,43
20	20	32	100		366220*	100,40	32	100	366320	110,71	38	100	366420	108,56

FRAISES CARBURE | ALU QUEUE RÉDUITE



d1	d2	l2	l1	r	Z	Référence	Code	€ promo ht
2	1,9	3	40	0,1	2	216 27 02-02040	277150	56,28
3	2,9	4	60	0,1	2	216 27 02-03060	277151	56,28
4	3,8	5	60	0,1	2	216 27 02-04060	277152	56,28
5	4,8	8	70	0,1	2	216 27 02-05070	277153	63,87
6	5,8	8	100	0,1	2	216 27 02-06100	277154	73,47
8	7,8	10	100	0,1	2	216 27 02-08100	277155	86,71
10	9,7	14	100	0,1	2	216 27 02-10100	277156	100,10
12	11,7	16	125	0,1	2	216 27 02-12125	277157	133,47
16	15,7	20	125	0,1	2	216 27 02-16125	277158	190,68

▲
queue réduite



Schaft / Queue Tol. h7:

Zähne Dents: **2**

Typ / Type Tol. h7: **W**

λ_s : **27°**

Schneidstoff Matière: **HM**

Zentrumschneiden Coupe au centre:

Material Selection: P, M, K, N, S, H

FRAISES HÉMISPHERIQUE ALU

Articles 2.411 ...

ALUMINIUM



NEW, TYP W, 2, R, 45°, polished, HA, Norm, ta-C, HSC, ALU NE, Kunststoff plastic, GFK/CFK, KSS, HP

TIALN

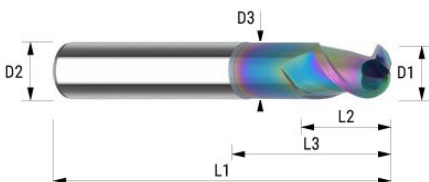

Désignation	D1	D2	L2	L1	L3	Code	Prix promo € net HT
VHM-fraise hémisphérique ø 3,0 mm	3.0	3.0	6	50	16	277020	45,79
VHM-fraise hémisphérique ø 4,0 mm	4.0	4.0	7	54	17	277021	45,79
VHM-fraise hémisphérique ø 5,0 mm	5.0	5.0	8	54	18	277022	45,79
VHM-fraise hémisphérique ø 6,0 mm	6.0	6.0	10	54	21	277023	45,79
VHM-fraise hémisphérique ø 8,0 mm	8.0	8.0	12	59	27	277024	56,03
VHM-fraise hémisphérique ø 10,0 mm	10.0	10.0	13	67	32	277025	74,23
VHM-fraise hémisphérique ø 12,0 mm	12.0	12.0	16	73	38	277026	94,97
VHM-fraise hémisphérique ø 16,0 mm	16.0	16.0	20	83	44	277071	157,86

Articles 941 ...

ALUMINIUM

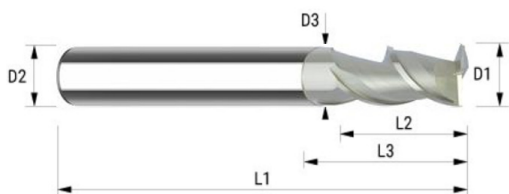

Désignation	D1	D2	L2	L1	L3	Code	Prix promo € net HT
VHM-Alucutter ø 3,0 mm	3.0	3.0	8	57	16	366063	15,13
VHM-Alucutter ø 4,0 mm	4.0	4.0	11	57	18	366064	15,13
VHM-Alucutter ø 5,0 mm	5.0	5.0	13	57	20	366065	15,13
VHM-Alucutter ø 6,0 mm	6.0	6.0	13	57	20	366066	16,81
VHM-Alucutter ø 8,0 mm	8.0	8.0	19	63	26	366068	25,21
VHM-Alucutter ø 10,0 mm	10.0	10.0	22	72	29	366070	33,12
VHM-Alucutter ø 12,0 mm	12.0	12.0	26	83	36	366072	45,37
VHM-Alucutter ø 14,0 mm	14.0	14.0	26	83	36	366075	57,62
VHM-Alucutter ø 16,0 mm	16.0	16.0	32	92	42	366076	69,63
VHM-Alucutter ø 18,0 mm	18.0	18.0	32	92	42	366078	90,04
VHM-Alucutter ø 20,0 mm	20.0	20.0	38	104	52	366080	114,99

FRAISES CARBURE | FRAISES HPC

Articles 2.415

ALUMINIUM

FRAISE CARBURE HPC À TROUS D'HUILE

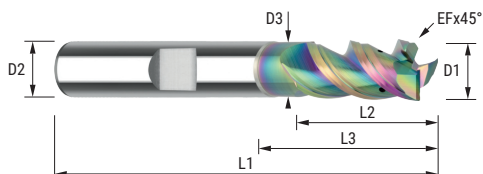

D1	D2	L2	L1	D3	L3	EF	Z	Référence	Code	€ promo ht
3,00 *	6,00	12	57	2,90	14	0,10	3	241503000	364460	70,99
4,00 *	6,00	12	57	3,90	15	0,10	3	241504000	364461	70,99
5,00	6,00	15	57	4,90	18	0,10	3	241505000	364462	66,87
6,00	6,00	15	57	5,80	21	0,10	3	241506000	364463	64,77
8,00	8,00	22	64	7,80	28	0,10	3	241508000	364464	75,68
10,00	10,00	25	73	9,70	33	0,20	3	241510000	364465	95,38
12,00	12,00	28	84	11,70	39	0,20	3	241512000	364466	116,56
16,00	16,00	35	93	15,70	45	0,20	3	241516000	364467	172,32
20,00	20,00	41	104	19,50	52	0,20	3	241520000	364468	268,72

Articles 2.416

FRAISE CARBURE HPC TORIQUE

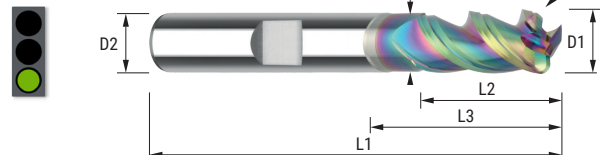
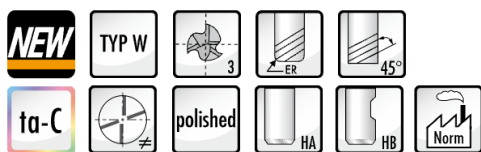

D1	D2	L2	L1	D3	L3	EF	Z	Référence	Code	€ promo ht
5,00	6,00	15	57	4,90	18	0,50	3	241605000	364469	45,08
5,00	6,00	15	57	4,90	18	1,00	3	241605100	364470	45,08
6,00	6,00	15	57	5,80	21	0,50	3	241606000	364471	45,08
6,00	6,00	15	57	5,80	21	1,00	3	241606100	364472	45,08
8,00	8,00	22	64	7,80	28	0,50	3	241608000	364473	50,08
8,00	8,00	22	64	7,80	28	1,00	3	241608100	364474	50,08
10,00	10,00	25	73	9,70	33	0,50	3	241610000	364475	62,26
10,00	10,00	25	73	9,70	33	1,00	3	241610100	364476	62,26
12,00	12,00	28	84	11,70	39	0,50	3	241612000	364477	90,27
12,00	12,00	28	84	11,70	39	1,00	3	241612100	364478	90,27
12,00	12,00	28	84	11,70	39	2,00	3	241612200	364479	90,27
16,00	16,00	35	93	15,70	45	1,00	3	241616000	364480	149,48
16,00	16,00	35	93	15,70	45	2,00	3	241616100	364481	149,48
20,00	20,00	41	104	19,50	52	1,00	3	241620000	364482	235,53
20,00	20,00	41	104	19,50	52	2,00	3	241620100	364483	235,53

FRAISES CARBURE | USINAGE DYNAMIQUE 3Z

InovaTools
GERMAN TOOLS GROUP

ALUMINIUM

Articles 590 ...

DEUX TAILLES CARBURE MONOBLOC ALUMINIUM

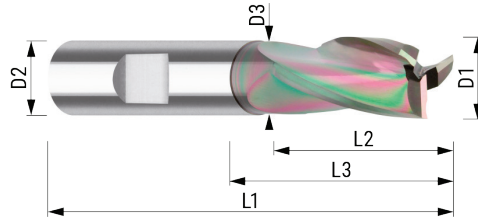

D1	D2 H6	L2	L1	D3	L3	Z	Articles	HA	HB	Code		Prix promo € net HT
										HA	HB	
4,00	4,00	13	54	3,70	16	2	590.04000		363939		45,71
5,00	5,00	15	54	4,70	18	2	590.05000		363940		47,09
6,00	6,00	16	64	5,70	21	2	590.06000	.10	363941	363917	50,15
8,00	8,00	22	70	7,50	27	2	590.08000	.10	363942	363918	65,63
10,00	10,00	25	72	9,50	32	2	590.10000	.10	363943	363919	87,61
12,00	12,00	28	83	11,50	38	3	590.12000	.10	363944	363921	105,22
14,00	14,00	30	83	13,50	42	3	590.14000	.10	363945	363936	137,86
16,00	16,00	36	92	15,50	44	3	590.16000	.10	363946	363922	174,47
18,00	18,00	36	92	17,50	50	3	590.18000	.10	363947	363937	207,01
20,00	20,00	41	104	19,50	54	4	590.20000	.10	363948	363920	268,19
25,00	25,00	43	110	24,50	63	4	590.25000	.10	363949	363938	369,89

FRAISES CARBURE | FRAISE D'ÉBAUCHE 3Z

InovaTools
GERMAN TOOLS GROUP

ALUMINIUM

Articles 251 ...

FRAISE D'ÉBAUCHE CARBURE
MONOBLOC AVEC TROUS D'HUILE PRIMUS

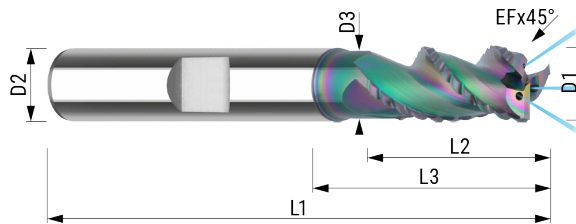

D1	D2 H6	L2	L1	D3	L3	ER	Z	Articles	Code	Prix promo € net HT
6,00	6,00	14	57	5,70	20	0,20	3	251.060.00	3630020	77,41
8,00	8,00	21	63	7,40	26	0,25	3	251.080.00	3630021	89,47
10,00	10,00	23	72	9,50	31	0,30	3	251.100.00	3630022	109,39
12,00	12,00	27	83	11,00	37	0,35	2	251.120.00	3630023	134,42
16,00	16,00	36	92	15,00	43	0,40	3	251.160.00	3630024	184,48
20,00	20,00	41	104	19,00	52	0,40	3	251.200.00	3630025	259,48

FRAISES CARBURE | FRAISE D'ÉBAUCHE 3Z

InovaTools
GERMAN TOOLS GROUP

ALUMINIUM

Articles 2.413

FRAISE D'ÉBAUCHE CARBURE
MONOBLOC PRIMUS

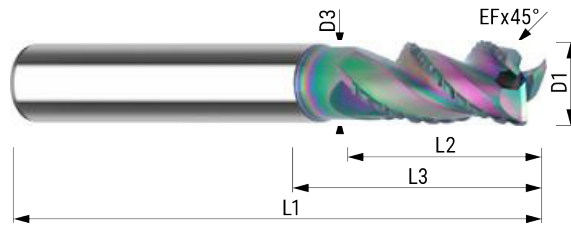

D1	D2 H6	L2	L1	D3	L3	EF	Z	Articles	Code	Prix promo € net HT
6,00	6,00	14	57	5,90	20	0,20	3	2413.060.00	3630073	59,64
8,00	8,00	21	63	7,80	26	0,25	3	2413.080.00	3630074	68,92
10,00	10,00	23	72	8,00	31	0,30	3	2413.100.00	3630075	84,28
12,00	12,00	27	83	11,70	37	0,35	3	2413.120.00	3630076	103,58
16,00	16,00	36	92	15,70	43	0,40	3	2413.160.00	3630077	142,13
20,00	20,00	41	104	19,50	52	0,40	3	2413.200.00	3630078	199,92

FRAISES CARBURE | FRAISE TORIQUE ALUMINIUM 2Z

InovaTools
GERMAN TOOLS GROUP

ALUMINIUM

Articles 2.408... / 2.409...

FRAISE TORIQUES CARBURE
MONOBLOC AVEC RAYON

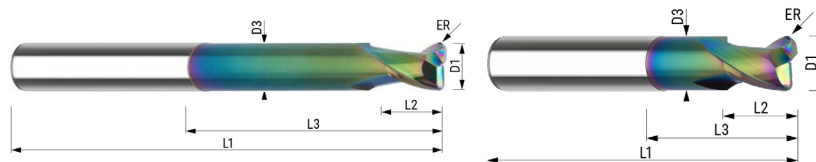

								2.408				2.409			
D1	D2 H6	L2	L1	D3	ER	Z	L3	Articles	Code	Prix promo € net HT	L3	Articles	Code	Prix promo € net HT	
3,00	6,00	4	75	2,90	0,30	2	32	2408.030.00	3630026	48,82	14	2409.030.00	3630042	36,80	
4,00	6,00	5	75	3,90	0,30	2	36	2408.040.00	3630027	54,07	16	2409.040.00	3630043	42,22	
5,00	6,00	6	75	4,90	0,30	2	40	2408.050.00	3630028	59,68	18	2409.050.00	3630044	45,58	
6,00	6,00	7	80	5,80	0,30	2	44	2408.060.00	3630029	64,39	21	2409.060.00	3630045	50,45	
6,00	6,00	7	80	5,80	1,00	2	44	2408.061.00	3630030	64,39	21	2409.061.00	3630046	50,45	
6,00	6,00	7	80	5,80	2,00	2	44	2408.062.00	3630031	64,39	21	2409.062.00	3630047	50,45	
8,00	8,00	9	100	7,80	0,30	2	54	2408.080.00	3630032	90,24	27	2409.080.00	3630048	67,62	
8,00	8,00	9	100	7,80	1,00	2	54	2408.081.00	3630033	90,24	27	2409.081.00	3630049	67,62	
8,00	8,00	9	100	7,80	2,00	2	54	2408.082.00	3630034	90,24	27	2409.082.00	3630050	67,62	
10,00	10,00	11	100	9,70	0,30	2	60	2408.100.00	3630035	121,63	32	2409.100.00	3630051	89,54	
10,00	10,00	11	100	9,70	1,50	2	60	2408.101.00	3630036	121,63	32	2409.101.00	3630052	89,54	
10,00	10,00	11	100	9,70	3,00	2	60	2408.102.00	3630037	121,63	32	2409.102.00	3630053	89,54	
12,00	12,00	13	120	11,70	1,50	2	75	2408.120.00	3630038	162,31	38	2409.120.00	3630054	120,26	
12,00	12,00	13	120	11,70	4,00	2	75	2408.121.00	3630039	162,31	38	2409.121.00	3630055	120,26	
16,00	16,00	17	150	15,70	2,00	2	92	2408.160.00	3630040	273,97	44	2409.160.00	3630056	196,20	
16,00	16,00	17	150	15,70	5,00	2	92	2408.161.00	3630041	273,97	44	2409.161.00	3630057	196,20	

FRAISES CARBURE | FRAISE TORIQUE ALUMINIUM 2Z | 3Z

Articles 2.414

USINAGE DYNAMIQUE

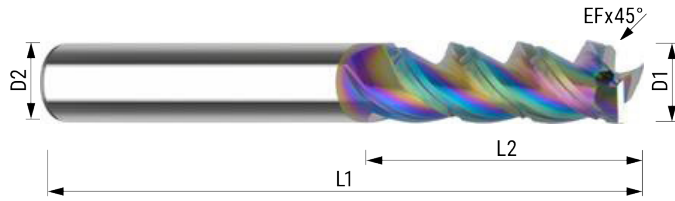

D1	D2 H6	L2	L1	EF	Z	Articles	Code	Prix promo € net HT
6,00	6,00	21	62	0,20	3	2414.060.00	3630079	59,13
8,00	8,00	28	68	0,20	3	2414.080.00	3630080	64,39
10,00	10,00	35	80	0,20	3	2414.100.00	3630081	85,71
12,00	12,00	42	93	0,20	3	2414.120.00	3630082	128,39
16,00	16,00	56	108	0,20	3	2414.160.00	3630083	182,65
20,00	20,00	70	126	0,20	3	2414.200.00	3630084	257,67

FRAISES CARBURE | FRAISE TORIQUE ALUMINIUM 3Z

InovaTools
GERMAN TOOLS GROUP

ALUMINIUM

Articles 2.410

FRAISE CARBURE MONOBLOC
AVEC RAYON

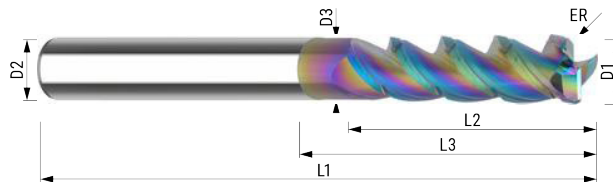

D1	D2 H6	L2	L1	D3	L3	ER	Z	Articles	Code	Prix promo € net HT
6,00	6,00	25	71	5,80	31	0,50	3	2410.060.00	3630058	49,18
6,00	6,00	25	71	5,80	31	1,00	3	2410.061.00	3630059	49,18
8,00	8,00	33	80	7,80	41	0,50	3	2410.080.00	3630060	58,41
8,00	8,00	33	80	7,80	41	1,00	3	2410.081.00	3630061	58,41
8,00	8,00	33	80	7,90	41	2,00	3	2410.082.00	3630062	58,41
10,00	10,00	41	95	9,70	51	0,50	3	2410.100.00	3630063	86,98
10,00	10,00	41	95	9,70	51	1,00	3	2410.101.00	3630064	86,98
10,00	10,00	41	95	9,70	51	2,00	3	2410.102.00	3630065	86,98
12,00	12,00	49	109	11,70	61	0,50	3	2410.120.00	3630066	118,45
12,00	12,00	49	109	11,70	61	1,00	3	2410.121.00	3630067	118,45
12,00	12,00	49	109	11,70	61	2,00	3	2410.122.00	3630068	118,45
16,00	16,00	65	132	15,80	81	2,00	3	2410.160.00	3630069	218,82
16,00	16,00	65	132	15,70	81	3,00	3	2410.161.00	3630070	218,82
20,00	20,00	82	154	19,50	101	2,00	3	2410.200.00	3630071	319,16
20,00	20,00	82	154	19,50	101	3,00	3	2410.201.00	3630072	319,16

FRAISES CARBURE | FRAISE ALUMINIUM 3Z



ALUMINIUM

Articles 945 ...

FRAISE AVEC ARRÊTE VIVE

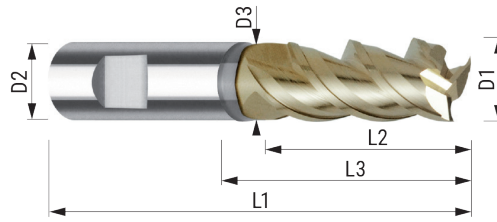

D1	D2	L2	L1	D3	L3	Z	Articles	Code	Prix promo € net HT
3,00	6,00	12	38	-	-	3	945.030.19	366982	20,55
4,00	6,00	12	54	3,80	18	3	945.040.19	366983	20,55
5,00	6,00	15	54	4,80	18	3	945.050.19	366984	20,55
6,00	6,00	16	57	5,80	21	3	945.060.19	366985	22,30
8,00	8,00	22	63	7,80	28	3	945.080.19	366986	32,65
10,00	10,00	25	72	9,70	33	3	945.100.19	366987	43,16
12,00	12,00	28	83	11,70	39	3	945.120.19	366988	57,58
16,00	16,00	35	93	15,70	45	3	945.160.19	366989	87,01
20,00	20,00	40	104	19,70	54	3	945.200.19	366990	135,40
25,00	25,00	40	121	23,00	65	3	945.250.19	366991	185,00

FRAISES CARBURE | FRAISE ALUMINIUM 3Z



ALUMINIUM

Articles 244 ...

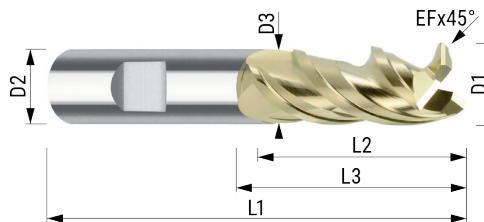

D1	D2	L2	L1	D3	L3	EF	Z	Articles	HA	HB	Code		Prix promo € net HT
											HA	HB	
3,00	6,00	8	57	2,80	12	0,10	3	244.03000	.10	363810		37,24
4,00	6,00	11	57	3,80	18	0,10	3	244.04000	.10	363811		37,24
5,00	6,00	13	57	4,80	18	0,10	3	244.05000	.10	363812		37,24
6,00	6,00	13	57	0,80	18	0,20	3	244.06000	.10	363813		39,15
6,00	6,00	13	80	5,80	42	0,20	3	244.06100	.10	363814		52,52
8,00	8,00	21	63	7,80	25	0,20	3	244.08000	.10	363815		44,89
8,00	8,00	21	100	7,80	62	0,20	3	244.08100	.10	363816		69,70
10,00	10,00	22	72	9,70	30	0,20	3	244.10000	.10	363817		76,39
10,00	10,00	22	100	9,70	58	0,20	3	244.10100	.10	363818		100,25
12,00	12,00	26	83	11,70	36	0,20	3	244.12000	.10	363819		103,13
12,00	12,00	26	120	11,70	73	0,20	3	244.12100	.10	363820		143,23
16,00	16,00	36	92	15,70	42	0,20	3	244.16000	.10	363821		191,67
16,00	16,00	36	150	15,70	100	0,20	3	244.16100	.10	363822		306,27
18,00	18,00	36	92	17,60	15	0,20	3	244.18000	.10	363823		211,72
18,00	18,00	36	150	17,60	100	0,20	3	244.18100	.10	363824		325,36
20,00	20,00	41	104	19,50	52	0,20	3	244.20000	.10	363825		274,12
20,00	20,00	41	150	19,50	98	0,20	3	244.20100	.10	363826		335,90
25,00	25,00	50	121	24,50	65	3,00	3	244.25000	.10	363827		357,25

FRAISES CARBURE | FRAISE ALUMINIUM CARBURE 3Z NON REVETUE



ALUMINIUM

APFE2000/3000



DC	Tolerance
Ø1 - Ø5	0.000 - -0.020
Ø6 - Ø8	0.000 - -0.025
Ø10 - Ø20	0.000 - -0.030

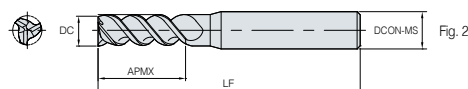
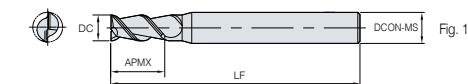

DC	DCON-MS	APMX	LF	Fig.	Référence	Code	€ promo ht
6	6	18	50	1	6-01-027843	368642	19,80
8	8	20	60	1	6-01-027844	368643	27,28
10	10	30	75	1	6-01-027845	368644	37,91
12	12	32	75	1	6-01-027846	368645	46,81
16	16	45	100	1	6-01-027847	368647	113,89
20	20	45	100	1	6-01-027848	368649	177,45
6	6	18	50	2	6-01-027833	280160	20,38
8	8	20	60	2	6-01-027834	280161	28,09
10	10	30	75	2	6-01-027835	280162	39,05
12	12	32	75	2	6-01-027836	280163	48,21
16	16	45	100	2	6-01-027837	280164	117,31
20	20	45	100	2	6-01-027838	280165	182,79

APMFE3000

DC	Tolerance
Ø1 - Ø5	0.000 - -0.020
Ø6 - Ø8	0.000 - -0.025
Ø10 - Ø20	0.000 - -0.030

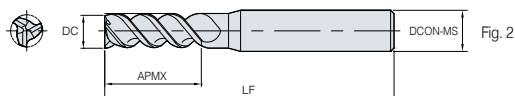

DC	DCON-MS	APMX	LF	Référence	€ tarif ht
3	6	11	60	6-01-042447	25,00
4	6	14	60	6-01-042448	25,00
5	6	17	60	6-01-042449	32,84
6	6	22	65	6-01-042450	35,61
8	8	25	65	6-01-042451	42,72
10	10	37	80	6-01-042452	63,11
12	12	40	80	6-01-042453	80,71
16	16	55	110	6-01-042454	154,35
20	20	60	125	6-01-042455	256,55

Tolérance ØD	e8
R Tolérance	±0.005 mm

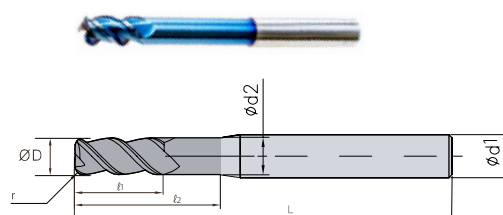
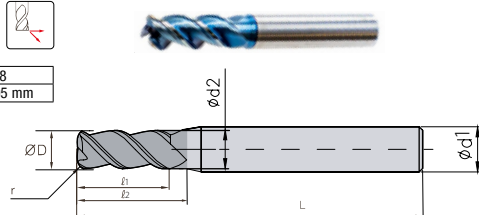

						APRE3000				APLRE3000					
ØD	Ød1	Ød2	R	Queue		L	I1	I2	Référence	€ tarif ht	L	I1	I2	Référence	€ tarif ht
5	6	4,7	0,5	HA		57	13	18	APRE3050-057-R05 KED1000	51,90	83	8	30	APLRE3050-083-R05 KED1000	66,80
5	6	4,7	1,0	HA		57	13	18	APRE3050-057-R10 KED1000	51,90	83	8	30	APLRE3050-083-R10 KED1000	66,80
6	6	5,7	0,5	HA		57	13	18	APRE3060-057-R05 KED1000	51,90	83	10	42	APLRE3060-083-R05 KED1000	66,80
6	6	5,7	1,0	HA		57	13	18	APRE3060-057-R10 KED1000	51,90	83	10	42	APLRE3060-083-R10 KED1000	66,80
8	8	7,4	0,5	HA		63	21	25	APRE3080-063-R05 KED1000	56,65	100	13	62	APLRE3080-100-R05 KED1000	87,24
8	8	7,4	1,0	HA		63	21	25	APRE3080-063-R10 KED1000	56,65	100	13	62	APLRE3080-100-R10 KED1000	87,24
10	10	9,2	0,5	HA		72	22	30	APRE3100-072-R05 KED1000	87,69	100	16	58	APLRE3100-100-R05 KED1000	120,68
10	10	9,2	1,0	HA		72	22	30	APRE3100-072-R10 KED1000	87,69	100	16	58	APLRE3100-100-R10 KED1000	120,68
10	10	9,2	2,0	HA		72	22	30	APRE3100-072-R20 KED1000	87,69	100	16	58	APLRE3100-100-R20 KED1000	120,68
12	12	11,0	0,5	HA		83	26	36	APRE3120-083-R05 KED1000	126,52	119	19	73	APLRE3120-119-R05 KED1000	162,43
12	12	11,0	1,0	HA		83	26	36	APRE3120-083-R10 KED1000	126,52	119	19	73	APLRE3120-119-R10 KED1000	162,43
12	12	11,0	2,0	HA		83	26	36	APRE3120-083-R20 KED1000	126,52	119	19	73	APLRE3120-119-R20 KED1000	162,43
16	16	15,0	1,0	HA		92	36	42	APRE3160-092-R10 KED1000	212,68	150	25	100	APLRE3160-150-R10 KED1000	290,32
16	16	15,0	2,0	HA		92	36	42	APRE3160-092-R20 KED1000	212,68	150	25	100	APLRE3160-150-R20 KED1000	290,32
16	16	15,0	3,0	HA		92	36	42	APRE3160-092-R30 KED1000	212,68	150	25	100	APLRE3160-150-R30 KED1000	290,32



Articles 953.1 ...

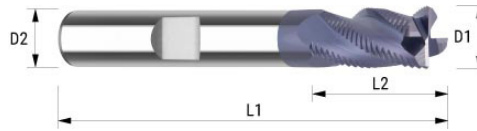

D1	D2	L2	L1	F	HA			HB		
					Articles	Code	Prix promo € net HT	Articles	Code	Prix promo € net HT
3,00	6,00	6	57	3	95310300	366721	12,99			
4,00	6,00	8	57	3	95310400	366722	12,99			
5,00	6,00	10	57	3	95310500	366723	12,99			
6,00	6,00	16	57	3	95310600	366826	14,26	95310610	366606	15,18
8,00	8,00	16	63	3	95310800	366828	18,87	95310810	366608	19,77
10,00	10,00	22	72	4	95311000	366830	26,45	95311010	366610	27,81
12,00	12,00	26	83	4	95311200	366832	38,95	95311210	366612	40,32
16,00	16,00	32	92	4	95311600	366836	62,73	95311610	366616	64,62
20,00	20,00	38	104	4	95312000	366840	105,26	95312010	366620	107,53

ACIER

Articles 953.2 ...

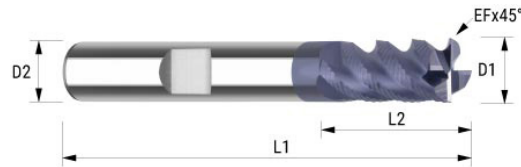

D1	D2	L2	L1	ER	F	HA			HB		
						Articles	Code	Prix promo € net HT	Articles	Code	Prix promo € net HT
4,00	6,00	11	57	0,15	3	95320400	366844	13,63	95320410	366704	14,54
5,00	6,00	13	57	0,15	4	95320500	366845	13,63	95320510	366705	14,54
6,00	6,00	16	57	0,15	4	95320600	366846	14,88	95320610	366706	15,79
8,00	8,00	16	53	0,15	4	95320800	366848	19,50	95320810	366708	20,40
10,00	10,00	22	72	0,2	4	95321000	366850	27,08	95321010	366710	28,45
12,00	12,00	28	83	0,2	4	95321200	366852	39,59	95321210	366712	40,94
16,00	16,00	32	92	0,25	5	95321600	366856	66,52	95321610	366716	68,40
20,00	20,00	38	104	0,25	6	95322000	366860	111,57	95322010	366720	113,83

FRAISES CARBURE | FRAISES À FILETER

INCONEL | TITANE | INOX | ACIER | ALUMINIUM



M	M FIN	UNC UNF	d	D	Z	l	L	1 DENT		2 DENTS	
								Code	Prix promo € net HT	Code	Prix promo € net HT
M2	0,35 - 0,40	N°2 (2,0xD)	4	1,50	4	4,4	50	093161	61,50	093143	73,80
M2	0,35 - 0,40	N°2 (3,0xD)	4	1,50	4	6,4	50	093162	67,65	093144	81,15
M2,2	0,45	N°2 (2,0xD)	4	1,65	4	5	50	093163	61,50	093145	73,80
M2,2	0,45	N°2 (3,0xD)	4	1,65	4	7,1	50	093164	67,65	093146	81,15
M2,5	0,45 - 0,50	N°3 (2,0xD)	4	1,90	4	5,5	50	093165	61,50	093147	73,80
M2,5	0,45 - 0,50	N°3 (3,0xD)	4	2,10	4	8	50	093166	67,65	093148	81,15
		N°4 (2,0xD)	4	2,10	4	6,4	50	093167	61,50		
		N°4 (3,0xD)	4	2,10	4	9,2	50	093168	67,65		
M3	0,50 - 0,60	N°5 (2,0xD)	4	2,30	4	6,5	50	093169	61,50	093149	73,80
M3	0,50 - 0,60	N°5 (3,0xD)	4	2,30	4	9,5	50	093170	67,65	093150	81,15
M3,5	0,50 - 0,75	N°6 (2,0xD)	4	2,60	4	7,6	50	093171	67,65	093151	73,80
M3,5	0,50 - 0,75	N°6 (3,0xD)	4	2,60	4	11,1	50	093172	61,50	093152	81,15
M4	0,70 - 0,75	N°8 (2,0xD)	4	3,00	4	9	50	093173	61,50	093153	73,80
M4	0,70 - 0,75	N°8 (3,0xD)	4	3,00	4	13	50	093174	67,65	093154	81,15
M4,5	0,75 - 1,00	N°10 (2,0xD)	4	3,60	4	10	50	093175	61,50		
M4,5	0,75 - 1,00	N°10 (3,0xD)	4	3,60	4	14,3	50	093176	67,65		
M5	0,75 - 1,00	N°12 (2,0xD)	4	4,00	4	11	50	093177	61,50	093155	73,80
M5	0,75 - 1,00	N°12 (3,0xD)	4	4,00	4	16	50	093178	67,65	093156	81,15
M6	1,00	(2,0xD)	4	3,80	4	11	50			093157	85,73
M6	1,00	(3,0xD)	4	3,80	4	16	50			093158	94,28
M8	1,25	(2,0xD)	4	4,50	4	13	63			093159	85,73
M8	1,14	(3,0xD)	4	4,50	4	19	76			093160	94,28

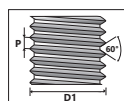
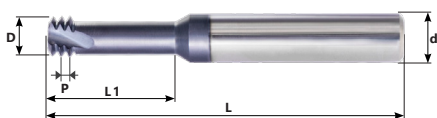

TiAlN beschichtet
TiAlN coated

Désignation	P	L	D1	d	D	L1	Z	Code	Prix promo € net HT
TMCM06024-3-6-0.5ISO	0,50	58	M3	6	2,37	6,5	3	076039	75,08
TMCM06031-3-9-0.7ISO	0,70	58	M4	6	3,10	9,0	3	076040	75,08
TMCM06038-3-12-0.8ISO	0,80	58	M5	6	3,80	12,5	3	076041	75,08
TMCM06047-3-14-1.0ISO	1,00	58	M6	6	4,65	14,0	3	076047	75,08
TMCM0606-3-18-1.25ISO	1,25	58	M8	6	6,00	18,0	3	076068	75,08
TMCM08078-3-23-1.5ISO	1,50	64	M10	8	7,80	23,0	3	076069	96,29
TMCM1009-3-26-1.75ISO	1,75	73	M12	10	9,00	26,0	3	076070	109,35
TMCM12118-4-35-2.0ISO	2,00	84	M16	12	11,80	35,0	4	076071	146,89
TMCM1615-5-43-2.5ISO	2,50	105	M20	16	15,00	43,0	5	076046	199,12

Désignation	P	L	D1	d	D	L1	Z	Prof.	Version	Code	Prix promo € net HT
TMCMC06024-4-6-0.5ISO	0,50	58	M3	6	2,40	6,5	4	2xD	A	076052	80,58
TMCMC06024-4-9-0.5ISO	0,50	58	M3	6	2,40	9,5	4	3xD	A	076053	89,14
TMCMC06032-4-8-0.7ISO	0,70	58	M4	6	3,20	8,7	4	2xD	C	076054	80,58
TMCMC06032-4-12-0.7ISO	0,70	58	M4	6	3,20	12,7	4	3xD	C	076055	89,14
TMCMC06038-4-10-0.8ISO	0,80	58	M5	6	3,80	10,8	4	2xD	C	076064	80,58
TMCMC06038-4-15-0.8ISO	0,80	58	M5	6	3,80	15,8	4	3xD	C	076065	89,14
TMCMC08048-4-13-1.0ISO	1,00	64	M6	8	4,80	13,0	4	2xD	C	076066	96,28
TMCMC08048-4-19-1.0ISO	1,00	64	M6	8	4,80	19,0	4	3xD	C	076067	96,28
TMCMC0606-4-25-1.25ISO	1,25	58	M8	6	6,00	25,3	4	3xD	C	076042	89,14
TMCMC0808-5-31-1.5ISO	1,50	64	M10	8	8,00	31,5	5	3xD	C	076043	111,45
TMCMC10095-5-37-1.75ISO	1,75	73	M12	10	9,50	37,8	5	3xD	C	076044	122,58
TMCMC1212-5-50-2.0ISO	2,00	105	M16	12	12,00	50,0	5	3xD	C	076045	161,20

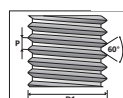
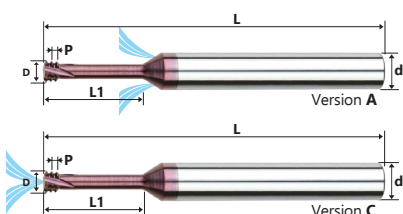

FRAISES HSS | FRAISE FINITION ACIER FRITTÉ WX6 - 505



TITANE | INOX | ACIER



Jusqu'au Ø20

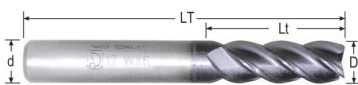

FRAISES DEUX TAILLES FINITION
SÉRIE MOYENNE

- NORME USINE
- COUPE AU CENTRE
- HÉLICE 40°

D Js14	Lt	LT	d h8	Z	Code	Prix promo € net HT	D Js14	Lt	LT	d h8	Z	Code	Prix promo € net HT
3	8	52	6	4	015597	12,51	14	32	92	16	4	015617	42,69
4	11	55	6	4	015598	12,51	15	36	96	16	4	015618	35,36
5	13	57	6	4	015599	13,65	16	36	96	16	4	015608	35,36
6	16	60	6	4	015600	14,35	17	40	100	16	4	015609	48,62
7	22	72	10	4	015601	20,89	18	40	100	16	4	015610	40,18
8	25	75	10	4	015602	20,89	19	45	105	16	4	015611	45,82
9	25	75	10	4	015603	20,89	20	45	111	20	4	015612	48,11
10	28	78	10	4	015604	20,89	22	46	111	20	5	015613	78,49
11	28	85	12	4	015605	27,31	25	50	126	25	5	015614	70,73
12	32	89	12	4	015606	27,31	30	63	139	25	6	015615	92,00
13	32	89	12	4	015607	32,13	32	63	143	32	6	015616	102,09

FRAISES HSS | FRAISE D'ÉBAUCHE ACIER FRITTÉ WX6 - 630C - 635C



TITANE | INOX | ACIER



Jusqu'au Ø20

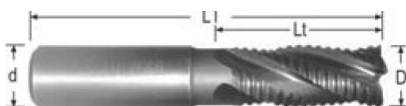

FRAISES RAVAGEUSES DEUX TAILLES
SÉRIE MOYENNE

- NORME USINE
- COUPE AU CENTRE
- HÉLICE 30°

D Js14	Lt	LT	d h6	Z	Code	Prix promo € net HT
6	13	57	6	3	015530	28,13
8	19	69	10	3	015532	38,78
10	22	72	10	3	015534	38,78
12	26	83	12	3	015536	42,69
14	26	83	12	4	015538	38,07
16	32	92	16	4	015540	54,35
18	32	92	16	4	015541	61,64
20	38	104	20	4	015543	65,04
25	45	121	25	4	015544	107,62

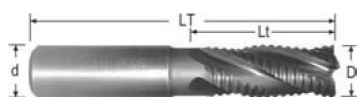

FRAISES RAVAGEUSES DEUX TAILLES
SÉRIE MOYENNE

- NORME USINE
- COUPE AU CENTRE
- HÉLICE 30°

D Js14	Lt	LT	d h6	Z	Code	Prix promo € net HT
6	16	60	6	3	015690	28,13
7	22	72	10	3	015691	38,78
8	25	75	10	3	015692	38,78
9	25	75	10	4	015693	38,78
10	28	78	10	4	015694	38,78
11	28	85	12	4	015695	42,69
12	32	89	12	4	015696	42,69
13	32	89	12	4	015697	47,55
14	32	92	16	4	015698	54,35
15	36	96	16	4	015699	54,35
16	36	96	16	4	015700	54,35
17	40	100	16	4	015701	60,18
18	40	100	16	4	015702	60,18
19	45	105	16	4	015703	65,04
20	45	111	20	4	015704	65,04
22	45	111	20	4	015705	81,53
25	50	126	25	5	015706	98,98
26	56	132	25	5	015709	145,62
30	63	139	25	5	015707	160,18
32	63	143	32	5	015708	131,04
35	63	143	32	6	015710	202,60
36	63	143	32	6	015711	266,95

FRAISES A CHANFREINER | COFFRET HSSE-E ULTIMATECUT



Diamètre	Désignation	Référence	Code	Prix promo € net HT
1 - 5,9	Coffret 50 forets HSS taillé Meulé Progression 0,1	214217	020819	94,00
6 - 10	Coffret 41 forets HSS Taillé Meulé Progression 0,1	214218	020820	200,78
1 - 13	Jeu de 25 forets Co5 - coffret ABS Progression 0,5	259215RO	020821	150,43
1 - 5,9	Coffret 50 forets Co5 Progression 0,1	215217RO	020822	89,78
6 - 10	Coffret 41 forets Co5 Progression 0,1	215218	020823	229,36

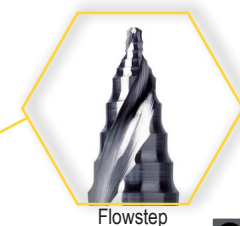

Flowstep

Diamètre	Désignation	Nb. pces	Article	Code	Prix € net HT	Article	Code	Prix RUaTEC € net HT
6,3 - 20,5 mm	ULTIMATECUT Set de fraises à chanfreiner HSS-E	6	102790ERO	011510	257,60	102790EPRO	011511	367,90
6,3 - 20,5 mm	ULTIMATECUT Set de fraises à chanfreiner HSS	6	102790RO	011512	206,18	102790PRO	011513	292,90
6,3 - 20,5 mm	ULTIMATECUT Set de fraises à chanfreiner HSS-E	5	102791ERO	011514	254,60	102791EPRO	011515	363,75
6,3 - 20,5 mm	ULTIMATECUT Set de fraises à chanfreiner HSS	5	102791RO	011516	203,75	102791PRO	011517	291,03

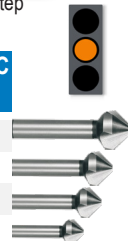

FRAISES A CHANFREINER



Articles 431 ...



D1	ANGLE	HSS E	
		Code	Prix € HT
4,30	90°	011860	9,32
4,80	90°		
5,00	90°	011861	9,32
5,30	90°	011862	9,55
5,80	90°		
6,00	90°	011863	9,55
6,30	90°	011864	9,55
7,00	90°		
7,30	90°		
8,00	90°	011865	10,71
8,30	90°	011866	11,03
9,40	90°		
10,00	90°	011867	12,36
10,40	90°	011868	12,77
11,50	90°	011869	13,91
12,40	90°	011870	14,05
13,40	90°		
15,00	90°	011871	15,48
16,50	90°	011872	16,46
19,00	90°	011873	23,55
20,50	90°	011874	24,02
23,00	90°	011875	29,97
25,00	90°	011876	33,21
28,00	90°	011877	46,54
31,00	90°	011878	46,54

D	d1	d2	L	Code	Prix promo € net HT
4,30	1,30	4	40	013330	11,16
5,00	1,50	4	40	013332	11,16
5,30	1,50	4	40	013333	11,16
6,00	1,50	5	45	013335	11,16
6,30	1,50	5	45	013336	11,16
7,00	1,80	6	50	013337	12,75
7,30	1,80	6	50	013338	12,75
8,00	2,00	6	50	013339	12,75
8,30	2,00	6	50	013340	12,75
9,40	2,20	6	50	013341	15,04
10,00	2,50	6	50	013342	15,04
10,40	2,50	6	50	013343	15,04
11,50	2,80	8	56	013344	17,59
12,40	2,80	8	56	013345	17,59
14,40	2,90	8	56	013346	22,51
15,00	3,20	10	60	013347	22,51
16,50	3,20	10	60	013348	22,51
19,00	3,50	10	63	013349	29,02
20,50	3,50	10	63	013350	29,02
23,00	3,80	10	67	013351	37,81
25,00	3,80	10	67	013352	37,81
28,00	4,00	12	71	013354	47,48
30,00	4,20	12	71	013355	56,28
31,00	4,20	12	71	013356	56,28
35,00	4,50	Morse 2	133	013353	88,82
37,00	4,50	Morse 2	145	013357	107,28

FRAISES A CHANFREINER | YT



REMISE 20%
À DÉDUIRE

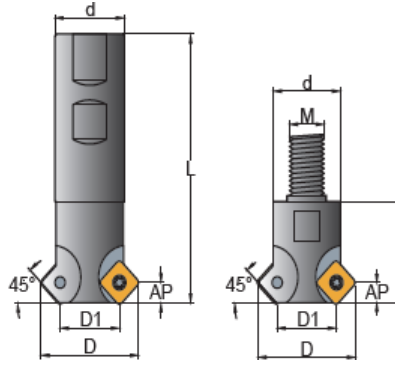

D	D1	d	L	AP	M	Z	INSERT	SCREW	KEY	Articles	Prix tarif € HT
18	11	12	90	3		2	SD 06	C025045	T08P	MC 1218	141,52
25	19	16	100	3		3	SD 06	C025045	T08P	MC 1625	145,45
32	22	20	100	6		2	SD 09	C04011	T15P	MC 2032	157,49
18	11	11	20	3	6	2	SD 06	C025045	T08P	HMC 18	133,66
25	19	15	30	3	8	3	SD 06	C025045	T08P	HMC 25	137,59
32	22	19	30	6	10	2	SD 09	C04011	T15P	HMC 32	149,23

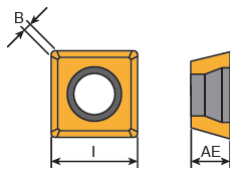

I	AE	B	Articles	Cdtnmt.	Prix tarif € HT
6,00	2,30	1,0	SDET060208N ME B100	10	12,32
9,00	3,97	1,2	SDET09T308TN M B100	10	13,55
9,00	3,97	1,2	SDET09T308TN ME B100	10	13,55

Déconditionnement
Majoration 15 %

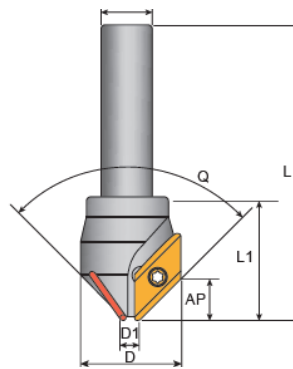

D1	D	d	L	AP	L1	Q	INSERT	SCREW	KEY	Articles	Prix tarif € HT
7,00	17,00	10,00	65,00	8,50	27,00	60°	XDGT120308	C03506	T10P	CI 17 60°	157,55
15,50	31,00	12,00	78,00	13,00	35,00	60°	XDGT19408	C04011	T15P	CI 31 60°	214,35
4,00	10,00	10,00	60,00		14,00	90°	ADGT060204	C01804	T06P	CI 12 90°	139,19
4,00	10,00	10,00	90,00	3,00	14,00	90°	ADGT060204	C01804	T06P	CI 12 90° L	143,90
5,50	22,00	10,00	65,00	8,00	27,00	90°	XDGT12308	C03506	T10P	CI 22 90°	157,55
15,00	36,00	12,00	78,00	10,00	38,00	90°	XDGT19408	C04011	T15P	CI 36 90°	226,80

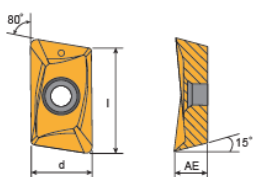

I	d	AE	Articles	Cdtnmt.	Prix tarif € HT
12,00	8,50	3,18	XDGT120308TR ME C B100	10	22,80
19,00	10,60	4,76	XDGT190408TR ME B100	10	29,11
40,00	10,60	4,76	XDGT400408TR ME B100	2	59,06
6,95	4,05	24,00	ADGT060204TR ME C B100	10	19,08

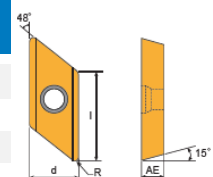

| TARIF ACTUEL EN VIGUEUR |

Déconditionnement
Majoration 15 %

FRAISES SCIES | YT - PLAQUETTES GAMME UFO



GAMME SB | SBL | 3T

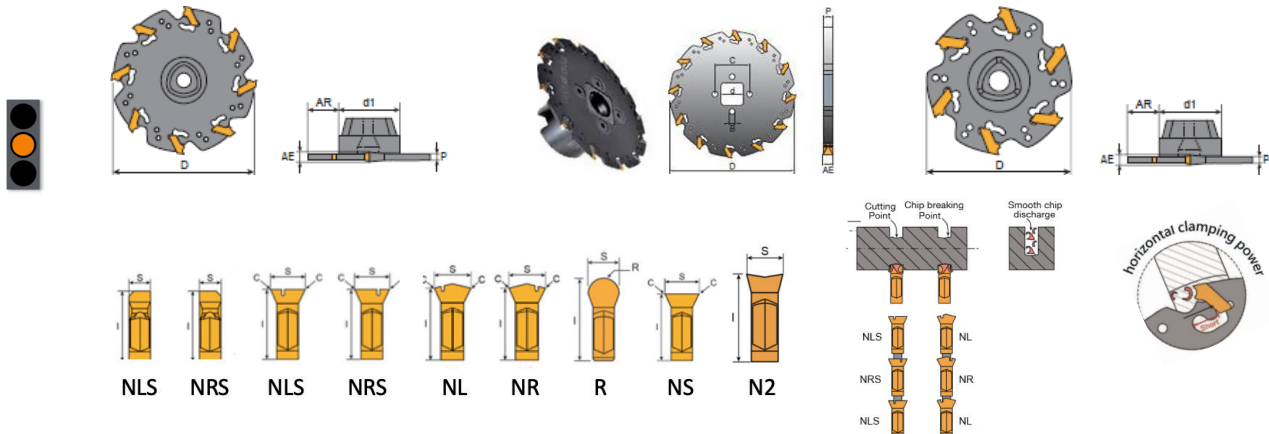

SB
Dia. 50-160 mm
Epaisseur 1.4-5.5mm

SBL
Dia. 80-160mm
Epaisseur 1.4-5.5mm

3T16/3T25
Dia. 32-80mm
Epaisseur 1.4-8mm

PORTE-OUTILS ET PLAQUETTES



Order Code	Dimensions (mm)						KG	Inserts 23 A23 B23	Screw	Key
	D	D1	d	L	L1	L2				
13-0808-60	8	7.9	8	60	20		0.06	0802	C02506 S025025	T08P L013
13-0808-85				85			0.07			
13-1008-60				60			0.09			
13-1010-65	10	9.9	10	65	30		0.09	1002	C03008 S02503	T09P L013
13-1010-100				100			0.12			
13-1010-150				150			0.12			
13-1210-65	12	11.9	12	65	35		0.12	1203	C03010 S0304	T09P L015
13-1212-80				80			0.12			
13-1212-110				110			0.15			
13-1212-160	12	11.9	12	160	35		0.18	1603	C03512 S0405	T10P L02
13-1612-80				80			0.21			
13-1616-100				100			0.21			
13-1616-130	16	15.8	16	130	35		0.26	1603	C03512 S0405	T10P L02
13-1616-180				180			0.36			

23 Inserts

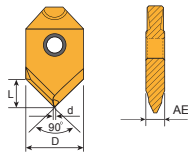

Tolerances (mm)

AE : + 0.01
- 0.02

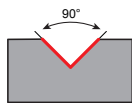

Dimensions (mm)					angle
D	d	L	AE		
8	0.7	4	2.0	90°	
10	0.8	5	2.5		
12	0.9	6	3.0		
16	1.0	8	3.0		

A23 Inserts

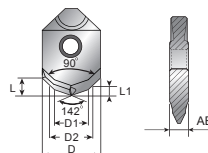

Tolerances (mm)

AE : + 0.01
- 0.02

Chamfering application

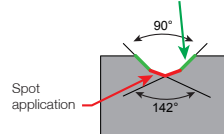

Dimensions (mm)								
D	L	D1	D2	L1	AE	M	angle	
8	2.8	3.3	4.2	1.02	2.0	M4 x 0.7	90° 142°	
10	3.5	4.2	5.25	1.25	2.5	M5 x 0.8		
12	4.2	5.0	6.3	1.55	3.0	M6 x 1.0		
16	5.6	6.8	8.4	1.97	3.0	M8 x 1.25		
16	5.1	8.5	10.5	2.46	3.0	M10 x 1.5		

B23 Inserts

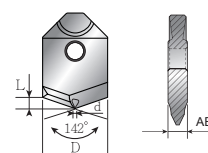

Tolerances (mm)

AE : + 0.01
- 0.02

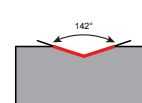

Dimensions (mm)					angle
D	d	L	AE		
8	0.7	1.28	2.0	142°	
10	0.8	1.55	2.5		
12	0.9	1.86	3.0		
16	1.0	2.56	3.0		

OUTILS CARBURE MULTIFONCTIONS



MULTI-V angle 90°

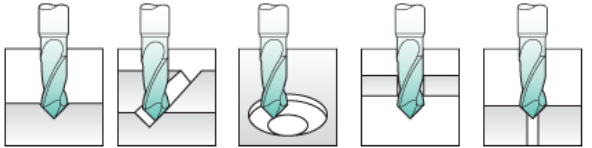

Centrage Pointage Rainurage en V Interpolation Perçage Chanfreinage

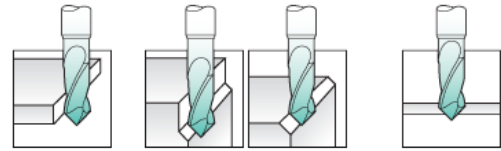

Contournage Chanfreins longitudinaux Chanfreins directs



Gravure

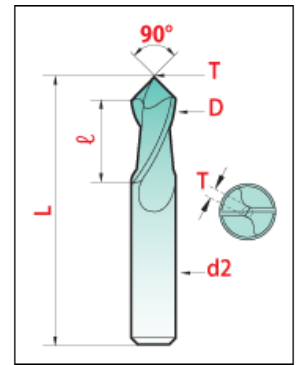

D	L	I	D2	T*	ANGLE	MULTI-V 8090		HARD'X 8090-H	
						Code	Prix promo € net HT	Code	Prix promo € net HT
0,50	39	1	3	0,05	90°				
1,00	39	2	3	0,10	90°			013978P	35,17
1,50	39	3	3	0,15	90°			013979P	35,17
2,00	39	4	3	0,20	90°	013809	30,77	013980P	35,17
2,50	39	5	3	0,25	90°			013981P	36,05
3,00	50	6	4	0,30	90°	013810	32,98	013982P	37,37
4,00	50	8	5	0,40	90°	013811	34,07	013983P	38,47
5,00	50	10	6	0,50	90°	013812	39,57		
6,00	60	12	8	0,60	90°	013813	43,96	013985P	48,37
8,00	70	16	10	0,80	90°	013814	64,64		
10,00	70	18	12	1,00	90°	013815	80,46	013987P	90,14
12,00	70	20	12	1,20	90°	013816	78,26	013988P	87,94

ÉBAVURAGE | POUR ACIERS, ALUMINIUM ET PLASTIQUES

NNG 8150
1 MANCHE NOGAGRIP
10 LAMES FORTES Ø 3 / 2 S10



NNG 8150
16,43 €

NNG 9100
LE MANCHE NOGAGRIP-3
LES PORTES-LAMENETS AVEC
LES LAMES PIVOTANTES : N1 |
N2 | S10 | S20 | S30 | S150



NNG 9100
26,55 €

FORETS | CARBURE 3XD / 5XD À TROUS D'HUILE

InovaTools
GERMAN TOOLS GROUP

Articles 652 ...

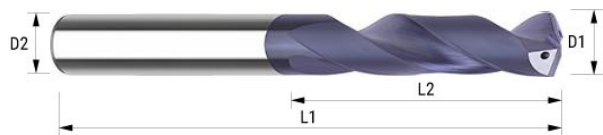

D1	D2	L2	L1	F	Articles	Code	Prix promo € net HT	D1	D2	L2	L1	F	Articles	Code	Prix promo € net HT
3,00	6,00	20	62	2	652.030.00	272571	23,29	9,50	10,00	47	89	2	652.095.00	272594	35,54
3,30	6,00	20	62	2	652.033.00	272572	23,29	9,80	10,00	47	89	2	652.098.00	272595	35,54
3,50	6,00	20	62	2	652.035.00	272573	23,29	10,00	10,00	47	89	2	652.100.00	272596	35,54
3,80	6,00	24	66	2	652.038.00	272574	23,29	10,20	12,00	55	102	2	652.102.00	272597	52,26
4,00	6,00	24	66	2	652.040.00	272575	23,29	10,50	12,00	55	102	2	652.105.00	272598	52,26
4,20	6,00	24	66	2	652.042.00	272576	23,29	10,80	12,00	55	102	2	652.108.00	272599	52,26
4,50	6,00	24	66	2	652.045.00	272577	23,29	11,00	12,00	55	102	2	652.110.00	272600	52,26
4,80	6,00	28	66	2	652.048.00	272578	23,29	11,50	12,00	55	102	2	652.115.00	272601	52,26
5,00	6,00	28	66	2	652.050.00	272579	23,29	11,80	12,00	55	102	2	652.118.00	272602	52,26
5,20	6,00	28	66	2	652.052.00	272580	23,29	12,00	12,00	55	102	2	652.120.00	272603	52,26
5,50	6,00	28	66	2	652.055.00	272581	23,29	12,50	14,00	60	107	2	652.125.00	272604	68,98
5,80	6,00	28	66	2	652.058.00	272582	23,29	12,80	14,00	60	107	2	652.128.00	272605	68,98
6,00	6,00	28	66	2	652.060.00	272583	23,29	13,00	14,00	60	107	2	652.130.00	272606	68,98
6,50	8,00	34	79	2	652.065.00	272584	30,27	13,50	14,00	60	107	2	652.135.00	272607	68,98
6,80	8,00	34	79	2	652.068.00	272585	30,27	13,80	14,00	60	107	2	652.138.00	272608	68,98
7,00	8,00	34	79	2	652.070.00	272586	30,27	14,00	14,00	60	107	2	652.140.00	272609	68,98
7,30	8,00	41	79	2	652.073.00	272587	30,27	14,50	16,00	65	115	2	652.145.00	272610	81,96
7,50	8,00	41	79	2	652.075.00	272588	30,27	14,80	16,00	65	115	2	652.148.00	272611	81,96
7,80	8,00	41	79	2	652.078.00	272589	30,27	15,00	16,00	65	115	2	652.150.00	272612	81,96
8,00	8,00	41	79	2	652.080.00	272590	30,27	15,20	16,00	65	115	2	652.152.00	272613	81,96
8,50	10,00	47	89	2	652.085.00	272591	35,54	15,50	16,00	65	115	2	652.155.00	272614	81,96
8,80	10,00	47	89	2	652.088.00	272592	35,54	15,80	16,00	65	115	2	652.158.00	272615	81,96
9,00	10,00	47	89	2	652.090.00	272593	35,54	16,00	16,00	65	115	2	652.160.00	272616	81,96

Articles 705 ...

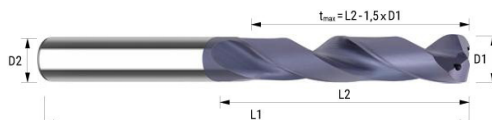

FORETS CARBURE POUR TROU DE GUIDAGE
POUR PERÇAGE PROFOND



D1	D2	L2	L1	Référence	Code	Prix promo € net HT	D1	D2	L2	L1	Référence	Code	Prix promo € net HT	Code	Prix promo € net HT
1,00	3,00	10	55	705.010...	270955	30,11	3,02	6,00	28	66	705.302...	2700029	25,43	2700030	25,43
1,10	3,00	12	55	705.011...	270956	30,11	3,22	6,00	28	66	705.322...	2700031	25,43	2700032	25,43
1,20	3,00	12	55	705.012...	270957	30,11	3,32	6,00	28	66	705.332...	2700033	25,43	2700034	25,43
1,30	3,00	12	55	705.013...	270958	30,11	3,52	6,00	28	66	705.352...	2700035	25,43	2700036	25,43
1,40	3,00	12	55	705.014...	270959	30,11	3,82	6,00	36	74	705.382...	2700037	27,56	2700038	27,56
1,50	3,00	12	55	705.015...	270960	30,11	4,02	6,00	36	74	705.402...	2700039	29,58	2700040	29,58
1,60	3,00	16	55	705.016...	270961	30,11	4,22	6,00	36	74	705.422...	2700041	29,58	2700042	29,58
1,70	3,00	16	55	705.017...	270962	30,11	4,52	6,00	36	74	705.452...	2700043	30,28	2700044	30,28
1,80	3,00	16	55	705.018...	270963	30,11	4,82	6,00	44	82	705.482...	2700045	33,01	2700046	33,01
1,90	3,00	16	55	705.019...	270964	30,11	5,02	6,00	44	82	705.502...	2700047	30,83	2700048	30,83
2,00	3,00	21	57	705.020...	2700011	29,56	5,52	6,00	44	82	705.552...	2700049	30,83	2700050	30,83
2,02	3,00	16	57	705.202...	2700012	27,66	5,82	6,00	44	82	705.582...	2700051	30,83	2700052	30,83
2,10	3,00	21	57	705.021...	270966	29,56	6,02	6,00	44	82	705.602...	2700053	32,85	2700054	32,85
2,20	3,00	21	57	705.022...	270967	29,56	6,52	8,00	53	91	705.652...	2700055	43,61	2700056	43,61
2,22	3,00	21	57	705.222...	2700015	27,66	6,82	8,00	53	91	705.682...	2700057	43,61	2700058	43,61
2,30	3,00	21	57	705.023...	270968	29,56	7,02	8,00	53	91	705.702...	2700059	45,69	2700060	45,69
2,32	3,00	21	57	705.232...	2700017	27,66	7,52	8,00	53	91	705.752...	2700061	45,69	2700062	45,69
2,40	3,00	21	57	705.024...	270969	29,56	7,82	8,00	53	91	705.782...	2700063	45,69	2700064	45,69
2,42	3,00	21	57	705.242...	2700019	27,66	8,02	8,00	53	91	705.802...	2700065	47,03	2700066	47,03
2,50	3,00	21	57	705.025...	270970	29,49	8,52	8,00	61	103	705.852...	2700067	53,74	2700068	53,74
2,52	3,00	21	57	705.252...	2700021	27,66	8,82	10,00	61	103	705.882...	2700069	53,74	2700070	53,74
2,60	3,00	21	57	705.026...	2700022	29,49	9,02	10,00	61	103	705.902...	2700071	53,74	2700072	53,74
2,70	3,00	21	57	705.027...	270972	29,49	9,82	10,00	61	103	705.982...	2700073	54,41	2700074	54,41
2,72	3,00	21	57	705.272...	2700024	27,59	10,02	10,00	61	103	705.983...	2700075	56,15	2700076	56,15
2,75	3,00	21	57	705.275...	2700025	27,59	10,22	12,00	71	118	705.984...	2700077	74,28	2700078	74,28
2,80	3,00	21	57	705.028...	270973	29,49	10,82	12,00	71	118	705.985...	2700079	74,28	2700080	74,28
2,82	3,00	21	57	705.282...	2700027	27,59	11,82	12,00	71	118	705.986...	2700081	76,34	2700082	76,34
2,90	3,00	21	57	705.029...	270974	29,49	12,02	12,00	71	118	705.987...	2700083	77,73	2700084	77,73

FORETS | HÉLICOÏDAUX CARBURE MONOBLOC HPC 5D



INCONEL | TITANE | INOX | ACIER | ALUMINIUM | FONTE

Articles 845 ...

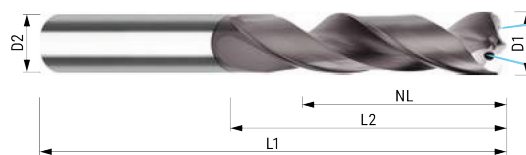

D1	D2	L2	L1	NL	Code	Prix promo € net HT	D1	D2	L2	L1	NL	Code	Prix promo € net HT	D1	D2	L2	L1	NL	Code	Prix promo € net HT	
3,00	6	28	66	23	272150	27,89	6,80	8	53	91	43	272189	33,12	10,70	12	71	118	56	272228	52,29	
3,10	6	28	66	23	272151	27,89	6,90	8	53	91	43	272190	33,12	10,80	12	71	118	56	272229	52,29	
3,20	6	28	66	23	272152	27,89	7,00	8	53	91	43	272191	33,12	10,90	12	71	118	56	272230	52,29	
3,30	6	28	66	23	272153	27,89	7,10	8	53	91	43	272192	33,12	11,00	12	71	118	56	272231	52,29	
3,40	6	28	66	23	272154	27,89	7,20	8	53	91	43	272193	33,12	11,10	12	71	118	56	272232	52,29	
3,50	6	28	66	23	272155	27,89	7,30	8	53	91	43	272194	33,12	11,20	12	71	118	56	272233	52,29	
3,60	6	28	66	23	272156	27,89	7,40	8	53	91	43	272195	33,12	11,30	12	71	118	56	272234	52,29	
3,70	6	28	66	23	272157	27,89	7,50	8	53	91	43	272196	33,12	11,40	12	71	118	56	272235	52,29	
3,80	6	36	74	29	272158	27,89	7,60	8	53	91	43	272197	33,12	11,50	12	71	118	56	272236	52,29	
3,90	6	36	74	29	272159	27,89	7,70	8	53	91	43	272198	33,12	11,60	12	71	118	56	272237	52,29	
4,00	6	36	74	29	272160	27,89	7,80	8	53	91	43	272199	33,12	11,70	12	71	118	56	272238	52,29	
4,10	6	36	74	29	272161	27,89	7,90	8	53	91	43	272200	33,12	11,80	12	71	118	56	272239	52,29	
4,20	6	36	74	29	272162	27,89	8,00	8	53	91	43	272201	33,12	11,90	12	71	118	56	272240	52,29	
4,30	6	36	74	29	272163	27,89	8,10	10	61	103	49	272202	40,09	12,00	12	71	118	56	272241	52,29	
4,40	6	36	74	29	272164	27,89	8,20	10	61	103	49	272203	40,09	12,20	14	77	124	60	272242	76,69	
4,50	6	36	74	29	272165	27,89	8,30	10	61	103	49	272204	40,09	12,30	14	77	124	60	272243	76,69	
4,60	6	36	74	29	272166	27,89	8,40	10	61	103	49	272205	40,09	12,50	14	77	124	60	272244	76,69	
4,65	6	36	74	29	272167	48,50	8,50	10	61	103	49	272206	40,09	12,80	14	77	124	60	272245	76,69	
4,70	6	36	74	29	272168	27,89	8,60	10	61	103	49	272207	40,09	13,00	14	77	124	60	272246	76,69	
4,80	6	44	82	35	272169	27,89	8,70	10	61	103	49	272208	40,09	13,50	14	77	124	60	272247	76,69	
4,90	6	44	82	35	272170	27,89	8,80	10	61	103	49	272209	40,09	13,80	14	77	124	60	272248	76,69	
5,00	6	44	82	35	272171	27,89	8,90	10	61	103	49	272210	40,09	14,00	14	77	124	60	272249	76,69	
5,10	6	44	82	35	272172	27,89	9,00	10	61	103	49	272211	40,09	14,50	16	83	133	63	272250	94,12	
5,20	6	44	82	35	272173	27,89	9,10	10	61	103	49	272212	40,09	14,80	16	83	133	63	272251	94,12	
5,30	6	44	82	35	272174	27,89	9,20	10	61	103	49	272213	40,09	15,00	16	83	133	63	272252	94,12	
5,40	6	44	82	35	272175	27,89	9,30	10	61	103	49	272214	40,09	15,50	16	83	133	63	272253	94,12	
5,50	6	44	82	35	272176	27,89	9,40	10	61	103	49	272215	40,09	15,80	16	83	133	63	272254	94,12	
5,60	6	44	82	35	272177	27,89	9,50	10	61	103	49	272216	40,09	16,00	16	83	133	63	272255	94,12	
5,70	6	44	82	35	272178	27,89	9,60	10	61	103	49	272217	40,09	16,50	18	93	143	71	272256	128,98	
5,80	6	44	82	35	272179	27,89	9,70	10	61	103	49	272218	40,09	16,80	18	93	143	71	272257	128,98	
5,90	6	44	82	35	272180	27,89	9,80	10	61	103	49	272219	40,09	17,00	18	93	143	71	272258	128,98	
6,00	6	44	82	35	272181	27,89	9,90	10	61	103	49	272220	40,09	17,50	18	93	143	71	272259	128,98	
6,10	8	53	91	43	272182	33,12	10,00	10	61	103	49	272221	40,09	17,80	18	93	143	71	272260	128,98	
6,20	8	53	91	43	272183	33,12	10,10	12	71	118	56	272222	52,29	18,00	18	93	143	71	272261	128,98	
6,30	8	53	91	43	272184	33,12	10,20	12	71	118	56	272223	52,29	18,50	18	93	143	71	272262	163,84	
6,40	8	53	91	43	272185	33,12	10,30	12	71	118	56	272224	52,29	19,00	18	93	143	71	272263	163,84	
6,50	8	53	91	43	272186	33,12	10,40	12	71	118	56	272225	52,29	19,50	18	93	143	71	272264	163,84	
6,60	8	53	91	43	272187	33,12	10,50	12	71	118	56	272226	52,29	20,00	18	93	143	71	272265	163,84	
6,70	8	53	91	43	272188	33,12	10,60	12	71	118	56	272227	52,29								

Le saviez-vous ?

Existe aussi en queue Weldon



FORETS FRITTÉ REVETU - CYLINDRIQUES COURTS

NACHI

Autre Ø sur demande
0,01 sur demande jusqu'au Ø8



3D
7572P



D1 mm	D2 mm	L2 mm	L1 mm	Code 7572P	Prix tarif € HT	D1 mm	D2 mm	L2 mm	L1 mm	Code 7572P	Prix tarif € HT	D1 mm	D2 mm	L2 mm	L1 mm	Code 7572P	Prix tarif € HT
1,30	3	8	40	028719	9,62	5,10	6	26	70	028751	20,54	8,50	10	37	87	028785	28,77
2,00	3	12	44	028720	8,69	5,50	6	28	72	028755	20,54	8,90	10	37	87	028786	30,77
2,50	3	14	46	028725	10,38	5,55	6	28	72	028756	28,15	9,00	10	40	90	028787	30,77
3,00	3	16	48	028730	10,38	5,90	6	28	72	028757	22,08	9,50	10	40	90	028795	32,69
3,30	4	18	50	028733	12,38	6,00	6	28	72	028760	22,08	10,00	10	43	93	028800	34,46
3,50	4	20	52	028735	12,38	6,50	8	31	75	028765	23,00	10,20	12	43	100	028802	37,31
4,00	4	22	54	028740	13,46	6,80	8	34	78	028766	24,00	10,50	12	43	100	028805	37,31
4,20	6	22	66	028742	15,38	6,90	8	34	79	028769	24,00	11,00	12	47	104	028806	41,08
4,50	6	24	68	028745	15,38	7,00	8	34	78	028770	24,00	11,50	12	47	104	028815	46,15
4,55	6	24	68	028746	22,00	7,50	8	34	78	028775	25,15	12,00	12	51	108	028820	49,85
4,65	6	24	68	028744	22,00	8,00	8	37	81	028777	26,46						
5,00	6	26	70	028750	17,15	8,30	8	37	81	028778	28,77						

Exemple

Perçage tôle INOX 304L

Foret 7572P Ø8

Vc 16 m/mn

N 640 tr/mn

F = 64 mm/mn soit 0,1 tour/mn

Profondeur 2 mm

338 trous, pas d'usure

Les forets carbures monobloc
cassaient par manque de rigidité



FORETS FRITTÉ REVETU - CYLINDRIQUES COURTS

NACHI

Autre Ø sur demande
0,01 sur demande jusqu'au Ø8



5D
6568P



D1 mm	L1 mm	L2 mm	Code 6568P	Prix tarif € HT	D1 mm	L1 mm	L2 mm	Code 6568P	Prix tarif € HT
2,00	44	16	028520	7,10	6,80	92	46	028568	26,45
2,50	50	20	028525	7,32	6,90	92	46	028569	26,45
3,00	54	22	028530	7,32	7,00	92	46	028570	23,04
3,30	57	24	028533	10,80	7,50	92	46	028575	24,13
3,50	61	26	028535	10,80	8,00	98	50	028580	25,14
4,00	65	29	028540	11,38	8,50	98	50	028585	29,86
4,10	65	29	028541	11,96	9,00	105	54	028590	29,13
4,20	65	29	028542	11,96	9,50	105	54	028595	34,78
4,30	65	29	028543	13,77	10,00	111	58	028600	34,78
4,50	69	32	028545	11,96	10,20	111	58	028602	37,97
5,00	74	35	028550	14,06	10,50	111	58	028605	37,97
5,10	74	35	028551	15,87	11,00	119	63	028610	57,39
5,50	80	38	028555	15,87	11,50	119	63	028615	59,71
6,00	80	38	028560	16,30	12,00	127	68	028620	61,81
6,20	86	42	028562	25,36					
6,50	86	42	028565	22,32					

FORETS | HÉLICOÏDAUX CARBURE MONOBLOC 8D



Articles 708 ...

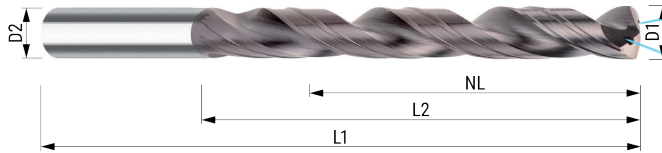

D1M7	D2H6	L1	L2	NL	Code	Prix promo € net HT	D1M7	D2H6	L1	L2	NL	Code	Prix promo € net HT
1,00	3,00	55	11	9,00	270190	35,11	7,00	8,00	114	76	60,00	270710	84,43
1,10	3,00	55	17	13,50	270191	35,11	7,10	8,00	114	76	60,00	270711	84,43
1,20	3,00	55	17	13,50	270192	35,11	7,20	8,00	114	76	60,00	270712	84,43
1,30	3,00	55	17	13,50	270193	35,11	7,30	8,00	114	76	60,00	270713	84,43
1,40	3,00	55	17	13,50	270194	35,11	7,40	8,00	114	76	60,00	270714	84,43
1,50	3,00	55	17	13,50	270195	35,11	7,50	8,00	114	76	60,00	270715	86,15
1,60	3,00	65	22	17,50	270196	35,11	7,60	8,00	114	76	60,00	270716	86,15
1,70	3,00	65	22	17,50	270197	35,11	7,70	8,00	114	76	60,00	270717	91,23
1,80	3,00	65	22	17,50	270198	35,11	7,80	8,00	114	76	60,00	270718	91,23
1,90	3,00	65	22	17,50	270199	35,11	7,90	8,00	114	76	60,00	270719	91,23
2,00	3,00	74	28	22,50	270411	36,52	8,00	8,00	114	76	60,00	270720	89,53
2,10	3,00	74	28	22,50	270412	36,52	8,10	10,00	142	95	68,00	270721	113,42
2,20	3,00	74	28	22,50	270413	36,52	8,20	10,00	142	95	68,00	270722	113,42
2,30	3,00	74	28	22,50	270414	36,52	8,30	10,00	142	95	68,00	270723	113,42
2,40	3,00	74	28	22,50	270415	36,52	8,40	10,00	142	95	68,00	270724	113,42
2,50	3,00	74	28	22,50	270416	37,69	8,50	10,00	142	95	68,00	270725	113,42
2,60	3,00	81	32	22,50	270417	37,69	8,60	10,00	142	95	68,00	270726	113,42
2,70	3,00	81	32	22,50	270418	37,69	8,70	10,00	142	95	68,00	270727	113,42
2,80	3,00	81	32	22,50	270419	37,69	8,80	10,00	142	95	68,00	270728	113,42
2,90	3,00	81	32	22,50	270420	37,69	8,90	10,00	142	95	68,00	270729	113,42
3,00	6,00	72	34	27,00	270670	46,06	9,00	10,00	142	95	68,00	270730	114,28
3,10	6,00	72	34	27,00	270671	46,06	9,10	10,00	142	95	76,00	270731	114,28
3,20	6,00	72	34	27,00	270672	46,06	9,20	10,00	142	95	76,00	270732	114,28
3,30	6,00	72	34	27,00	270673	46,06	9,30	10,00	142	95	76,00	270733	114,28
3,40	6,00	72	34	27,00	270674	46,06	9,40	10,00	142	95	76,00	270734	114,28
3,50	6,00	72	34	27,00	270675	46,06	9,50	10,00	142	95	76,00	270735	115,12
3,60	6,00	72	34	27,00	270676	46,92	9,60	10,00	142	95	76,00	270736	115,12
3,70	6,00	72	34	27,00	270677	46,92	9,70	10,00	142	95	76,00	270737	116,01
3,80	6,00	86	43	35,00	270678	48,60	9,80	10,00	142	95	76,00	270738	116,01
3,90	6,00	86	43	35,00	270679	48,60	9,90	10,00	142	95	76,00	270739	116,01
4,00	6,00	86	43	35,00	270680	49,48	10,00	10,00	142	95	76,00	270740	120,23
4,10	6,00	86	43	35,00	270681	51,16	10,10	12,00	162	114	90,00	270741	151,78
4,20	6,00	86	43	35,00	270682	51,16	10,20	12,00	162	114	90,00	270742	151,78
4,30	6,00	86	43	35,00	270683	51,16	10,30	12,00	162	114	90,00	270743	152,64
4,40	6,00	86	43	35,00	270684	51,16	10,40	12,00	162	114	90,00	270744	152,64
4,50	6,00	86	43	35,00	270685	52,86	10,50	12,00	162	114	90,00	270745	153,48
4,60	6,00	86	43	35,00	270686	56,28	10,60	12,00	162	114	90,00	270746	153,48
4,70	6,00	86	43	35,00	270687	67,18	10,70	12,00	162	114	90,00	270747	154,36
4,80	6,00	95	57	45,00	270688	56,28	10,80	12,00	162	114	90,00	270748	154,36
4,90	6,00	95	57	45,00	270689	57,98	10,90	12,00	162	114	90,00	270749	154,36
5,00	6,00	95	57	45,00	270690	57,98	11,00	12,00	162	114	90,00	270750	155,22
5,10	6,00	95	57	45,00	270691	57,98	11,10	12,00	162	114	90,00	270751	155,22
5,20	6,00	95	57	45,00	270692	57,98	11,20	12,00	162	114	90,00	270752	156,06
5,30	6,00	95	57	45,00	270693	57,98	11,30	12,00	162	114	90,00	270753	156,06
5,40	6,00	95	57	45,00	270694	57,98	11,40	12,00	162	114	90,00	270754	156,06
5,50	6,00	95	57	45,00	270695	57,98	11,50	12,00	162	114	90,00	270755	156,92
5,60	6,00	95	57	45,00	270696	57,98	11,60	12,00	162	114	90,00	270756	156,92
5,70	6,00	95	57	45,00	270697	57,98	11,70	12,00	162	114	90,00	270757	157,76
5,80	6,00	95	57	45,00	270698	58,84	11,80	12,00	162	114	90,00	270758	157,76
5,90	6,00	95	57	45,00	270699	62,24	11,90	12,00	162	114	90,00	270759	157,76
6,00	6,00	95	57	45,00	270700	62,24	12,00	12,00	162	114	90,00	270760	158,60
6,10	8,00	114	76	52,00	270701	80,15	12,50	14,00	184	133	106,00	270421	223,76
6,20	8,00	114	76	52,00	270702	83,60	12,80	14,00	184	133	106,00	270422	223,76
6,30	8,00	114	76	52,00	270703	83,60	13,00	14,00	184	133	106,00	270423	223,76
6,40	8,00	114	76	52,00	270704	83,60	13,50	14,00	184	133	106,00	270424	223,76
6,50	8,00	114	76	52,00	270705	84,43	14,00	14,00	184	133	106,00	270425	223,76
6,60	8,00	114	76	52,00	270706	84,43	14,50	16,00	203	152	122,00	270426	301,37
6,70	8,00	114	76	52,00	270707	84,43	15,00	16,00	203	152	122,00	270427	301,37
6,80	8,00	114	76	52,00	270708	84,43	15,50	16,00	203	152	122,00	270428	301,37
6,90	8,00	114	76	52,00	270709	84,43	16,00	16,00	203	152	122,00	270429	301,37

Le savez-vous ?

Inovatools fait des micros forets :

InovaTools
GERMAN TOOLS GROUP



Famille 506 - Ø 0,1 - 3,0 par incrément de 0,05
3xD non revetue

Famille 507 - Ø 0,1 - 3,0 par incrément de 0,01
5xD revetue

Famille 508 - Ø 0,1 - 2,05 par incrément de 0,01
8xD non revetue

FORETS | CARBURE 12xD À TROUS D'HUILE

InovaTools
GERMAN TOOLS GROUP

Articles 710 ...

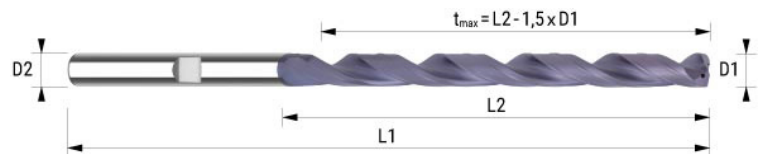

D1	D2	L2	L1	Articles	Code	Prix promo € net HT	D1	D2	L2	L1	Articles	Code	Prix promo € net HT	D1	D2	L2	L1	Articles	Code	Prix promo € net HT	
1,00	3,00	15	55	71001000	270890	45,86	3,30	6,00	54	92	71003300	270911	78,65	9,00	10,00	120	162	71009000	270930	178,85	
1,10	3,00	23	55	71001100	270891	45,86	3,50	6,00	54	92	71003500	270912	78,65	9,50	10,00	120	162	71009500	270931	178,85	
1,20	3,00	23	55	71001200	270892	45,86	3,80	6,00	64	102	71003800	270913	80,03	9,80	10,00	120	162	71009800	270932	178,85	
1,30	3,00	23	55	71001300	270893	45,86	4,00	6,00	64	102	71004000	270914	80,03	10,00	10,00	120	162	71010000	270933	178,85	
1,40	3,00	23	55	71001400	270894	45,86	4,20	6,00	64	102	71004200	270915	80,03	10,20	12,00	156	204	71010200	270934	244,52	
1,50	3,00	30	65	71001500	270895	45,86	4,50	6,00	64	102	71004500	270916	80,03	10,50	12,00	156	204	71010500	270935	244,52	
1,60	3,00	30	65	71001600	270896	45,86	4,80	6,00	78	118	71004800	270917	82,32	10,80	12,00	156	204	71010800	270936	244,52	
1,70	3,00	30	65	71001700	270897	45,86	5,00	6,00	78	118	71005000	270918	82,32	11,00	12,00	156	204	71011000	270937	244,52	
1,80	3,00	30	65	71001800	270898	45,86	5,50	6,00	78	118	71005500	270919	82,32	11,50	12,00	156	204	71011500	270938	244,52	
1,90	3,00	30	65	71001900	270899	45,86	5,80	6,00	78	118	71005800	270920	82,32	11,80	12,00	156	204	71011800	270939	244,52	
2,00	3,00	38	74	71002000	270900	47,52	5,90	6,00	78	118	71005900	270991	82,32	12,00	12,00	156	204	71012000	270940	244,52	
2,10	3,00	38	74	71002100	270901	47,52	6,00	6,00	78	118	71006000	270921	82,32	12,50	14,00	182	230	71012500	270941	330,81	
2,20	3,00	38	74	71002200	270902	47,52	6,50	8,00	108	146	71006500	270922	133,34	12,80	14,00	182	230	71012800	270942	330,81	
2,30	3,00	38	74	71002300	270903	47,52	6,80	8,00	108	146	71006800	270923	133,34	13,00	14,00	182	230	71013000	270943	330,81	
2,40	3,00	38	74	71002400	270904	47,52	7,00	8,00	108	146	71007000	270924	133,34	13,50	14,00	182	230	71013500	270944	330,81	
2,50	3,00	44	81	71002500	270905	50,93	7,50	8,00	108	146	71007500	270925	133,34	14,00	14,00	182	230	71014000	270945	330,81	
2,60	3,00	44	81	71002600	270906	50,93	7,80	8,00	108	146	71007800	270926	133,34	14,50	16,00	208	260	71014500	270946	436,03	
2,70	3,00	44	81	71002700	270907	50,93	8,00	8,00	108	146	71008000	270927	133,34	15,00	16,00	208	260	71015000	270947	436,03	
2,80	3,00	44	81	71002800	270908	50,93	8,50	10,00	120	162	71008500	270928	178,85	15,50	16,00	208	260	71015500	270948	436,03	
2,90	3,00	54	81	71002900	270909	50,93	8,80	10,00	120	162	71008800	270929	178,85	16,00	16,00	208	260	71016000	270949	436,03	
3,00	6,00	54	92	71003000	270910	78,65															

FORETS CARBURE | SERIE LONGUE CARBURE 908 15D / 909 20D



Articles 908 ...

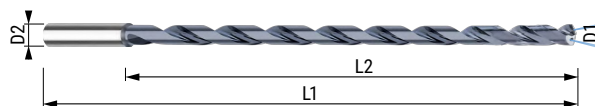

FORETS CARBURE REVÊTU



D1	D2H6	L1	L2	Code	Prix promo € net HT	D1	D2H6	L1	L2	Code	Prix promo € net HT	D1	D2H6	L1	L2	Code	Prix promo € net HT
1,00	3	75	18,20	272275	118,46	3,60	6	108	65,50	272301	149,36	6,20	8	148	108,00	272327	194,68
1,10	3	75	20,20	272276	118,46	3,70	6	108	70,50	272302	149,36	6,30	8	148	108,00	272328	194,68
1,20	3	75	24,20	272277	118,46	3,80	6	108	70,50	272303	149,36	6,40	8	148	108,00	272329	194,68
1,30	3	75	24,20	272278	118,46	3,90	6	108	70,70	272304	149,36	6,50	8	160	121,00	272330	194,68
1,40	3	75	27,20	272279	118,46	4,00	6	120	75,50	272305	165,32	6,60	8	160	121,00	272331	194,68
1,50	3	75	27,20	272280	118,46	4,10	6	120	75,50	272306	165,32	6,70	8	170	131,00	272332	194,68
1,60	3	75	30,20	272281	118,46	4,20	6	120	75,50	272307	165,32	6,80	8	170	131,00	272333	194,68
1,70	3	75	30,20	272282	118,46	4,30	6	120	80,50	272308	165,32	6,90	8	170	131,00	272334	194,68
1,80	3	75	35,20	272283	118,46	4,40	6	120	80,50	272309	165,32	7,00	8	170	131,00	272335	194,68
1,90	3	75	35,20	272284	118,46	4,50	6	120	80,50	272310	165,32	7,50	8	170	131,00	272336	194,68
2,00	4	80	35,50	272285	125,67	4,60	6	125	85,50	272311	165,32	7,80	8	180	141,00	272337	200,87
2,10	4	80	40,50	272286	125,67	4,70	6	125	85,50	272312	165,32	8,00	8	180	141,00	272338	200,87
2,20	4	80	40,50	272287	125,67	4,80	6	140	90,50	272313	165,32	8,50	10	198	155,00	272339	254,42
2,30	4	80	40,50	272288	125,67	4,90	6	140	90,50	272314	165,32	8,80	10	208	165,00	272340	254,42
2,40	4	90	45,50	272289	125,67	5,00	6	140	90,50	272315	165,32	9,00	10	208	165,00	272341	254,42
2,50	4	90	45,50	272290	125,67	5,10	6	140	95,50	272316	191,07	9,50	10	208	165,00	272342	254,42
2,60	4	90	48,50	272291	125,67	5,20	6	140	95,50	272317	191,07	9,80	10	208	165,00	272343	254,42
2,70	4	90	48,50	272292	125,67	5,30	6	140	95,50	272318	191,07	10,00	10	218	175,00	272344	254,42
2,80	4	90	50,50	272293	125,67	5,40	6	140	95,50	272319	191,07	10,20	12	235	187,00	272345	361,44
2,90	4	90	50,50	272294	125,67	5,50	6	150	100,50	272320	191,07	10,50	12	245	197,00	272346	361,44
3,00	6	100	55,50	272295	149,36	5,60	6	150	100,50	272321	191,07	10,80	12	245	197,00	272347	361,44
3,10	6	100	55,50	272296	149,36	5,70	6	150	100,50	272322	191,07	11,00	12	245	197,00	272348	361,44
3,20	6	100	60,50	272297	149,36	5,80	6	150	100,50	272323	191,07	11,20	12	245	197,00	272349	361,44
3,30	6	100	60,50	272298	149,36	5,90	6	150	100,50	272324	191,07	11,50	12	245	197,00	272350	361,44
3,40	6	100	60,50	272299	149,36	6,00	6	150	100,50	272325	191,07	11,80	12	255	207,00	272351	361,44
3,50	6	108	65,50	272300	149,36	6,10	8	148	108,00	272326	194,68	12,00	12	255	207,00	272352	361,44

Articles 909 ...

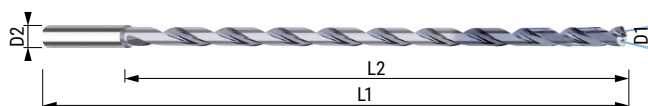

FORETS CARBURE REVÊTU



D1	D2H6	L1	L2	Code	Prix promo € net HT	D1	D2H6	L1	L2	Code	Prix promo € net HT
2,00	4	95	45,50	272353	125,67	5,00	6	160	115,50	272373	215,59
2,10	4	95	50,50	272354	125,67	5,50	6	185	140,50	272374	226,40
2,20	4	95	50,50	272355	125,67	5,80	6	185	140,50	272375	226,40
2,30	4	95	55,50	272356	125,67	6,00	6	185	140,50	272376	226,40
2,40	4	95	55,50	272357	125,67	6,50	8	190	150,00	272377	260,60
2,50	4	108	60,50	272358	125,67	6,80	8	200	160,00	272378	260,60
2,60	4	108	60,50	272359	125,67	7,00	8	210	170,00	272379	260,60
2,70	4	108	65,50	272360	125,67	7,50	8	210	170,00	272380	260,60
2,80	4	108	65,50	272361	125,67	7,80	8	230	190,00	272381	275,03
2,90	4	112	68,50	272362	125,67	8,00	8	230	190,00	272382	275,03
3,00	6	112	68,50	272363	186,85	8,50	10	240	196,00	272383	357,43
3,20	6	120	75,50	272364	186,85	8,80	10	260	216,00	272384	357,43
3,30	6	120	75,50	272365	186,85	9,00	10	260	216,00	272385	357,43
3,50	6	130	80,50	272366	186,85	9,80	10	280	236,00	272386	363,60
3,80	6	140	90,50	272367	186,85	10,00	10	280	236,00	272387	363,60
4,00	6	140	95,50	272368	186,85	10,20	12	290	241,00	272388	463,52
4,20	6	140	95,50	272369	186,85	10,80	12	315	266,00	272389	463,52
4,50	6	160	110,50	272370	201,17	11,80	12	315	266,00	272390	463,52
4,60	6	160	110,50	272371	201,17	12,00	12	315	266,00	272391	463,52
4,80	6	160	115,50	272372	215,59						

Articles 910 ...

FORETS CARBURE REVÊTU

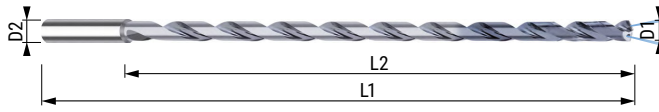

D1	D2H6	L1	L2	Code	Prix promo € net HT	D1	D2H6	L1	L2	Code	Prix promo € net HT
3,00	6	130	85,50	272392	231,77	7,00	8	240	201,00	272407	293,56
3,20	6	140	95,50	272393	231,77	7,50	8	250	214,00	272408	293,56
3,30	6	140	95,50	272394	231,77	7,80	8	260	224,00	272409	310,03
3,50	6	150	100,50	272395	231,77	8,00	8	260	224,00	272410	310,03
3,80	6	150	105,50	272396	238,98	8,50	10	280	237,00	272411	389,36
4,00	6	160	110,50	272397	238,98	8,80	10	290	247,00	272412	391,42
4,20	6	170	120,50	272398	238,98	9,00	10	290	247,00	272413	391,42
4,50	6	180	130,50	272399	247,93	9,50	10	310	267,00	272414	406,86
4,80	6	190	140,50	272400	256,90	9,80	10	310	267,00	272415	406,86
5,00	6	190	140,50	272401	256,90	10,00	10	310	267,00	272416	406,86
5,50	6	210	160,50	272402	262,35	10,20	12	340	295,00	272417	618,03
5,80	6	210	160,50	272403	262,35	10,80	12	350	302,00	272418	618,03
6,00	6	220	170,50	272404	262,35	11,80	12	375	327,00	272419	618,03
6,50	8	230	191,00	272405	293,56	12,00	12	375	327,00	272420	618,03
6,80	8	230	191,00	272406	293,56						

Articles 911 ...

FORETS CARBURE REVÊTU

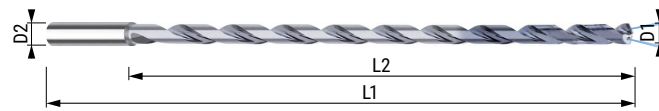

D1	D2H6	L1	L2	Code	Prix promo € net HT	D1	D2H6	L1	L2	Code	Prix promo € net HT
2,00	4	105	65,50	272421	141,63	5,00	6	210	165,50	272439	294,60
2,20	4	115	75,50	272422	141,63	5,50	6	240	180,50	272440	303,87
2,30	4	115	75,50	272423	141,63	5,80	6	240	190,50	272441	303,87
2,40	4	130	85,50	272424	141,63	6,00	6	240	190,50	272442	303,87
2,50	4	130	85,50	272425	141,63	6,50	8	260	222,00	272443	332,70
2,70	4	140	95,50	272426	141,63	6,80	8	260	222,00	272444	332,70
2,80	4	140	95,50	272427	141,63	7,00	8	270	232,00	272445	355,38
2,90	4	140	95,50	272428	141,63	7,50	8	290	252,00	272446	355,38
3,00	6	150	105,50	272429	263,70	7,80	8	300	262,00	272447	359,49
3,10	6	150	105,50	272430	263,70	8,00	8	305	267,00	272448	359,49
3,30	6	160	115,50	272431	276,05	8,50	10	320	278,00	272449	497,51
3,50	6	160	115,50	272432	276,05	8,80	10	340	298,00	272450	497,51
3,80	6	175	125,50	272433	276,05	9,00	10	340	298,00	272451	497,51
4,00	6	185	135,50	272434	282,22	9,50	10	360	318,00	272452	497,51
4,20	6	185	135,50	272435	282,22	9,80	10	380	338,00	272453	497,51
4,50	6	195	145,50	272436	282,22	10,00	10	380	338,00	272454	497,51
4,60	6	205	155,50	272437	282,22						
4,80	6	210	165,50	272438	294,60						

FORETS | FORET CARBURE 5XD À TROUS D'HUILE À FOND PLAT

Articles 818 ...

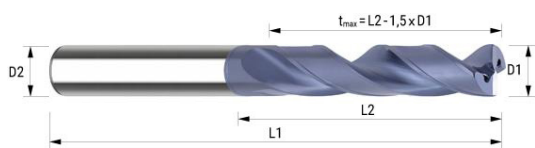

D1	D2	L2	L1	EF	Z	Articles	Code	Prix promo € net HT	D1	D2	L2	L1	EF	Z	Articles	Code	Prix promo € net HT	D1	D2	L2	L1	EF	Z	Articles	Code	Prix promo € net HT		
3,00	6,00	28	66	0,15	2	81803000	272617	67,39	6,60	8,00	53	91	0,33	2	81806600	272654	83,27	10,70	12,00	69	116	0,54	2	81810700	272691	134,58		
3,10	6,00	28	66	0,16	2	81803100	272618	67,39	6,70	8,00	53	91	0,34	2	81806700	272655	83,27	10,80	12,00	69	116	0,54	2	81810800	272692	134,58		
3,20	6,00	28	66	0,16	2	81803200	272619	67,39	6,90	8,00	53	91	0,35	2	81806900	272656	83,27	10,90	12,00	69	116	0,55	2	81810900	272693	134,58		
3,30	6,00	28	66	0,17	2	81803300	272620	67,39	7,00	8,00	53	91	0,35	2	81807000	272657	83,27	11,10	12,00	69	116	0,56	2	81811100	272694	134,58		
3,40	6,00	28	66	0,17	2	81803400	272621	67,39	7,10	8,00	53	91	0,36	2	81807100	272658	83,27	11,20	12,00	69	116	0,56	2	81811200	272695	134,58		
3,50	6,00	28	66	0,18	2	81803500	272622	67,39	7,20	8,00	53	91	0,36	2	81807200	272659	83,27	11,30	12,00	69	116	0,57	2	81811300	272696	134,58		
3,60	6,00	28	66	0,18	2	81803600	272623	67,39	7,30	8,00	53	91	0,37	2	81807300	272660	83,27	11,40	12,00	69	116	0,57	2	81811400	272697	134,58		
3,70	6,00	28	66	0,19	2	81803700	272624	67,39	7,40	8,00	53	91	0,37	2	81807400	272661	83,27	11,50	12,00	69	116	0,58	2	81811500	272698	134,58		
3,80	6,00	36	74	0,19	2	81803800	272625	67,39	7,50	8,00	53	91	0,38	2	81807500	272662	83,27	11,60	12,00	69	116	0,58	2	81811600	272699	134,58		
3,90	6,00	36	74	0,2	2	81803900	272626	67,39	7,60	8,00	53	91	0,38	2	81807600	272663	83,27	11,70	12,00	69	116	0,59	2	81811700	272700	134,58		
4,10	6,00	36	74	0,21	2	81804100	272627	67,39	7,70	8,00	53	91	0,39	2	81807700	272664	83,27	11,80	12,00	69	116	0,59	2	81811800	272701	134,58		
4,20	6,00	36	74	0,21	2	81804200	272628	67,39	7,80	8,00	53	91	0,39	2	81807800	272665	83,27	11,90	12,00	69	116	0,6	2	81811900	272702	134,58		
4,30	6,00	36	74	0,22	2	81804300	272629	67,39	7,90	8,00	53	91	0,4	2	81807900	272666	83,27	12,00	12,00	69	116	0,6	2	81812000	272703	134,58		
4,40	6,00	36	74	0,22	2	81804400	272630	67,39	8,10	10,00	61	103	0,41	2	81808100	272667	96,74	12,50	14,00	75	122	0,63	2	81812500	272704	206,22		
4,50	6,00	36	74	0,23	2	81804500	272631	67,39	8,20	10,00	61	103	0,42	2	81808200	272668	96,74	12,80	14,00	75	122	0,64	2	81812800	272705	206,22		
4,60	6,00	36	74	0,23	2	81804600	272632	67,39	8,30	10,00	61	103	0,42	2	81808300	272669	96,74	13,00	14,00	75	122	0,65	2	81813000	272706	206,22		
4,65	6,00	36	74	0,23	2	818046500	272633	67,39	8,40	10,00	61	103	0,42	2	81808400	272670	96,74	13,50	14,00	75	122	0,68	2	81813500	272707	206,22		
4,70	6,00	36	74	0,24	2	81804700	272634	67,39	8,50	10,00	61	103	0,43	2	81808500	272671	96,74	13,80	14,00	75	122	0,69	2	81813800	272708	206,22		
4,80	6,00	44	82	0,24	2	81804800	272635	70,65	8,60	10,00	61	103	0,43	2	81808600	272672	96,74	14,00	14,00	75	122	0,7	2	81814000	272709	206,22		
4,90	6,00	44	82	0,25	2	81804900	272636	70,65	8,70	10,00	61	103	0,44	2	81808700	272673	96,74	14,50	16,00	81	131	0,73	2	81814500	272710	231,32		
5,00	6,00	44	82	0,25	2	81805000	272637	70,65	8,80	10,00	61	103	0,44	2	81808800	272674	96,74	14,80	16,00	81	131	0,74	2	81814800	272711	231,32		
5,10	6,00	44	82	0,26	2	81805100	272638	70,65	8,90	10,00	61	103	0,45	2	81808900	272675	96,74	15,50	16,00	81	131	0,78	2	81815500	272712	231,32		
5,20	6,00	44	82	0,26	2	81805200	272639	70,65	9,10	10,00	61	103	0,46	2	81809100	272676	96,74	15,80	16,00	81	131	0,79	2	81815800	272713	231,32		
5,30	6,00	44	82	0,27	2	81805300	272640	70,65	9,20	10,00	61	103	0,46	2	81809200	272677	96,74	16,00	16,00	81	131	0,8	2	81816000	272714	231,32		
5,40	6,00	44	82	0,27	2	81805400	272641	70,65	9,30	10,00	61	103	0,47	2	81809300	272678	96,74	16,50	18,00	91	141	0,83	2	81816500	272715	302,82		
5,50	6,00	44	82	0,28	2	81805500	272642	70,65	9,40	10,00	61	103	0,47	2	81809400	272679	96,74	16,80	18,00	91	141	0,84	2	81816800	272716	302,82		
5,55	6,00	44	82	0,28	2	818055500	272643	70,65	9,50	10,00	61	103	0,48	2	81809500	272680	96,74	17,00	18,00	91	141	0,85	2	81817000	272717	302,82		
5,60	6,00	44	82	0,28	2	81805600	272644	70,65	9,60	10,00	61	103	0,48	2	81809600	272681	96,74	17,50	18,00	91	141	0,88	2	81817500	272718	302,82		
5,70	6,00	44	82	0,29	2	81805700	272645	70,65	9,70	10,00	61	103	0,49	2	81809700	272682	96,74	17,80	18,00	91	141	0,89	2	81817800	272719	302,82		
5,80	6,00	44	82	0,29	2	81805800	272646	70,65	9,80	10,00	61	103	0,49	2	81809800	272683	96,74	18,50	20,00	99	151	0,93	2	81818500	272720	386,95		
5,90	6,00	44	82	0,3	2	81805900	272647	70,65	9,90	10,00	61	103	0,5	2	81809900	272684	96,74	18,80	20,00	99	151	0,94	2	81818800	272721	386,95		
6,00	6,00	44	82	0,3	2	81806000	272648	70,65	10,10	12,00	69	116	0,51	2	81810100	272685	134,58	19,00	20,00	99	151	0,95	2	81819000	272722	386,95		
6,10	8,00	53	91	0,31	2	81806100	272649	83,27	10,20	12,00	69	116	0,51	2	81810200	272686	134,58	19,50	20,00	99	151	0,98	2	81819500	272723	386,95		
6,20	8,00	53	91	0,31	2	81806200	272650	83,27	10,30	12,00	69	116	0,52	2	81810300	272687	134,58	19,80	20,00	99	151	0,99	2	81819800	272724	386,95		
6,30	8,00	53	91	0,32	2	81806300	272651	83,27	10,40	12,00	69	116	0,52	2	81810400	272688	134,58	20,00	20,00	99	151	1	2	81820010	272725	388,70		
6,40	8,00	53	91	0,32	2	81806400	272652	83,27	10,50	12,00	69	116	0,53	2	81810500	272689	134,58											
6,50	8,00	53	91	0,33	2	81806500	272653	83,27	10,60	12,00	69	116	0,53	2	81810600	272690	134,58											

Le saviez-vous ?

Inovatools a une application, disponible sur Android et Apple ou ordinateur, pour trouver vos valeurs de coupe



InovaTools® INOCUT - Valeurs de coupe

NEWSLETTER LANGUES

Art.-Nr. Technologie Matière Tool Finder Détail Valeurs de coupe Dim. d'usinage / Rentabilité



Toutes les valeurs de coupe sont des valeurs catégorielles qui ont été déterminées sous des conditions optimales (équipement machine, refroidissement, serrage stable de la pièce à usiner). Inovatools, Eckerle&Eitel GmbH ne peut pas se porter garant pour des valeurs de coupe calculées. Les valeurs de base ont été déterminées par des essais, mais tous les enlèvements de matière individuelles sont calculés et adaptés aux limites enregistrées de la machine.

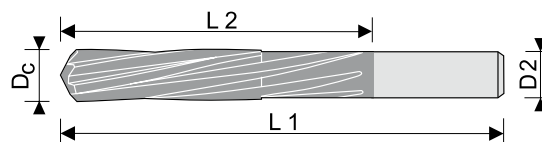

Dc	L2	L1	D2	Référence	Code	Prix promo € net HT
1,90	11	49	2	122.0190	250100	24,42
1,91 - 1,99	11	49	2	122.0191 - 122.0199	250101 - 250109	28,19
2,00	11	49	2	122.0200	250110	18,80
2,01 - 2,02	11	49	2	122.0201 - 122.0202	250111 - 250112	28,19
2,48 - 2,49	14	57	2,5	122.0248 - 122.0249	250158 - 250159	28,19
2,50	14	57	2,5	122.0250	250160	20,14
2,51 - 2,52	14	57	2,5	122.0251 - 122.0252	250161 - 250162	30,23
2,98 - 2,99	15	61	3	122.0298 - 122.0299	250208 - 250209	30,23
3,00	15	51	3	122.0300	250210	21,65
3,01 - 3,02	15	61	3	122.0301 - 122.0302	250211 - 250212	32,44
3,48 - 3,49	18	70	3,5	122.0348 - 122.0349	250258 - 250259	32,44
3,50	18	70	3,5	122.0350	250260	20,14
3,51 - 3,52	18	70	3,5	122.0351 - 122.0352	250261 - 250262	37,03
3,98 - 3,99	19	75	4	122.0398 - 122.0399	250308 - 250309	37,03
4,00	19	75	4	122.0400	250310	26,62
4,01 - 4,02	19	75	4	122.0401 - 122.0402	250311 - 250312	39,85
4,48 - 4,49	21	75	4,5	122.0448 - 122.0449	250358 - 250359	39,85
4,50	21	75	4,5	122.0450	250360	28,95
4,51 - 4,52	21	75	4,5	122.0451 - 122.0452	250361 - 250362	43,41
4,98 - 4,99	23	86	5	122.0498 - 122.0499	250408 - 250409	43,41
5,00	23	86	5	122.0500	250410	32,73
5,01 - 5,02	23	86	5	122.0501 - 122.0502	250411 - 250412	45,85
5,48 - 8,49	26	93	5,6	122.0548 - 122.0549	250458 - 250459	45,85
5,50	26	93	5,6	122.0550	250460	34,61
5,51 - 5,99	26	93	5,6	122.0551 - 122.0599	250461 - 250509	48,43
6,00	26	93	5,6	122.0600	250510	41,42
6,01 - 6,02	26	93	5,6	122.0601 - 122.0602	250511 - 250512	57,89
6,48 - 6,49	28	101	6,3	122.0648 - 122.0649	250558 - 250559	57,89
6,50	28	101	6,3	122.0650	250560	46,49
6,51 - 6,52	28	101	6,3	122.0651 - 122.0652	250561 - 250562	65,12
6,98 - 6,99	31	109	7,1	122.0698 - 122.0699	250608 - 250609	65,12
7,00	31	109	7,1	122.0700	250610	48,95
7,01 - 7,49	31	109	7,1	122.0701 - 122.0751	250611 - 250659	72,62
7,50	31	109	7,1	122.0750	250660	56,11
7,51 - 7,52	31	109	7,1	122.0751 - 122.0752	250661 - 250662	78,44
7,98 - 7,99	33	117	8	122.0798 - 122.0799	250708 - 250709	78,44
8,00	33	117	8	122.0800	250710	59,73
8,01 - 8,49	33	117	8	122.0801 - 122.0849	250711 - 250759	77,54
8,50	33	117	8	122.0850	250760	64,78
8,51 - 8,52	33	117	8	122.0851 - 122.0852	250761 - 250762	84,28
8,98 - 8,99	36	125	9	122.0898 - 122.0899	250808 - 250809	84,28
9,00	36	125	9	122.0900	250810	69,42
9,01 - 9,49	36	125	9	122.0901 - 122.0949	250811 - 250859	90,23
9,50	36	125	9	122.0950	250860	74,46
9,51 - 9,52	36	125	9	122.0951 - 122.0952	250861 - 250862	96,79



HSSCO5 DIN 338

DIN
338

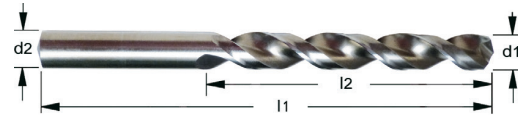

D1	L1	L2	Code	Cdtnmt.	Prix promo unit. € HT	D1	L1	L2	Code	Cdtnmt.	Prix promo unit. € HT	D1	L1	L2	Code	Cdtnmt.	Prix promo unit. € HT
1,00	34	12	022700S	10	1,53	5,75	93	57	022923	10	2,90	10,60	133	87	022889	5	10,37
1,10	36	14	022702	10	1,53	5,80	93	57	022796S	10	2,90	10,70	142	94	022890S	5	10,37
1,20	38	16	022704	10	1,53	5,90	93	57	022798S	10	2,90	10,80	142	94	022891S	5	10,37
1,25	38	16	022914	10	1,53	6,00	93	57	022800S	10	2,81	10,90	142	94	022892	5	10,37
1,30	38	16	022706	10	1,53	6,10	101	63	022802S	10	3,23	11,00	142	94	022893S	5	10,37
1,40	40	18	022708	10	1,53	6,20	101	63	022804S	10	3,23	11,10	142	94	022894S	5	10,37
1,50	40	18	022710S	10	1,45	6,25	101	63	022924	10	3,23	11,20	142	94	022895S	5	12,22
1,60	43	20	022712S	10	1,53	6,30	101	63	022806S	10	3,23	11,30	142	94	022896S	5	12,22
1,70	43	20	022714S	10	1,53	6,40	101	63	022808S	10	3,49	11,40	142	94	022897S	5	12,22
1,75	46	22	022915	10	1,97	6,50	101	63	022810S	10	3,23	11,50	142	94	022898S	5	12,22
1,80	46	22	022716S	10	1,53	6,60	101	63	022812S	10	3,49	11,60	142	94	022899	5	12,62
1,90	46	22	022718S	10	1,53	6,70	101	63	022814S	10	3,49	11,70	142	94	022900S	5	12,62
2,00	49	24	022720S	10	1,24	6,75	109	69	022816	5	3,78	11,80	142	94	022901S	5	12,62
2,10	49	24	022722S	10	1,24	6,80	109	69	022818S	10	3,78	11,90	151	101	022902	5	12,62
2,20	53	27	022724S	10	1,24	6,90	109	69	022820S	10	3,78	12,00	151	101	022903S	5	12,62
2,25	53	27	022916	10	1,28	7,00	109	69	022822S	10	3,47	12,10	151	101	022904S	5	15,65
2,30	53	27	022726S	10	1,24	7,10	109	69	022824S	10	4,52	12,20	151	101	022905S	5	15,65
2,40	57	30	022728S	10	1,34	7,20	109	69	022826S	10	4,52	12,30	151	101	022906S	5	15,65
2,50	57	30	022730S	10	1,28	7,25	109	69	022925	5	4,52	12,40	151	101	022907S	5	15,65
2,60	57	30	022732S	10	1,34	7,30	109	69	022828S	10	4,52	12,50	151	101	022908S	5	15,65
2,70	61	33	022734S	10	1,39	7,40	109	69	022830S	10	4,52	12,60	151	101	022909S	5	17,30
2,75	61	33	022917	10	1,39	7,50	117	75	022832S	10	4,52	12,70	151	101	022910S	5	17,30
2,80	61	33	022736S	10	1,39	7,60	117	75	022834S	10	5,23	12,80	151	101	022911S	5	17,30
2,90	61	33	022738S	10	1,41	7,70	117	75	022836S	10	5,23	12,90	151	101	022912S	5	17,30
3,00	61	33	022740S	10	1,34	7,75	117	75	022926	5	5,23	13,00	151	101	022913S	5	17,30
3,10	65	36	022742	10	1,41	7,80	117	75	022838S	10	5,23	13,50	160	108	020339S	5	17,16
3,20	65	36	022744S	10	1,41	7,90	117	75	022840S	10	5,23	14,00	160	108	022931	5	18,61
3,25	65	36	022918	10	1,45	8,00	117	75	022842S	10	5,23	14,50	169	114	020341S	5	29,53
3,30	65	36	022746S	10	1,45	8,10	117	75	022844S	10	5,23	15,00	169	114	020342S	5	35,24
3,40	70	39	022748S	10	1,64	8,20	117	75	022846S	10	5,23	15,50	178	120	020343S	5	40,05
3,50	70	39	022750S	10	1,64	8,25	117	75	022927	5	5,48	16,00	178	120	020344S	5	45,70
3,60	70	39	022752S	10	1,64	8,30	117	75	022848S	10	5,48	16,50	184	125	020345S	1	46,45
3,70	70	39	022754S	10	1,64	8,40	117	75	022850S	10	5,48	17,00	184	125	020346S	1	49,46
3,75	70	39	022919	10	1,76	8,50	117	75	022852S	10	5,48	17,50	191	130	020347S	1	40,13
3,80	75	43	022756S	10	1,76	8,60	125	81	022854S	10	6,45	18,00	191	130	020348S	1	53,95
3,90	75	43	022758S	10	1,79	8,70	125	81	022856S	10	6,45	18,50	198	135	020349S	1	57,14
4,00	75	43	022760S	10	1,76	8,75	125	81	022928	5	6,68	19,00	198	135	020350S	1	59,05
4,10	75	43	022762S	10	1,79	8,80	125	81	022858S	10	6,68	19,50	205	140	020351S	1	61,76
4,20	75	43	022764S	10	1,79	8,90	125	81	022860S	10	6,68	20,00	205	140	020352S	1	64,95
4,25	75	43	022920	10	1,97	9,00	125	81	022862S	10	6,22						
4,30	80	47	022766S	10	1,97	9,10	125	81	022864S	10	7,31						
4,40	80	47	022768S	10	1,97	9,20	125	81	022866S	10	7,31						
4,50	80	47	022770S	10	1,97	9,25	125	81	022929	5	7,69						
4,60	80	47	022772S	10	1,97	9,30	125	81	022868S	10	7,69						
4,70	80	47	022774S	10	1,97	9,40	125	81	022870S	10	7,69						
4,75	80	47	022921	10	2,04	9,50	125	81	022872S	10	6,89						
4,80	86	52	022776S	10	2,04	9,60	125	81	022874S	10	7,81						
4,90	86	52	022778S	10	2,12	9,70	133	87	022876S	10	7,81						
5,00	86	52	022780S	10	2,12	9,75	133	87	022930	5	8,19						
5,10	86	52	022782S	10	2,23	9,80	133	87	022878S	10	8,19						
5,20	86	52	022784S	10	2,23	9,90	133	87	022880S	10	8,19						
5,25	86	52	022922	10	2,23	10,00	133	87	022882S	5	7,31						
5,30	86	52	022786S	10	2,23	10,10	133	87	022883S	5	8,34						
5,40	93	57	022788S	10	2,81	10,20	133	87	022884S	5	8,34						
5,50	93	57	022790S	10	2,75	10,30	133	87	022886S	5	8,34						
5,60	93	57	022792S	10	2,90	10,40	133	87	022887S	5	8,34						
5,70	93	57	022794S	10	2,90	10,50	133	87	022888S	5	8,34						

Déconditionnement
Majoration 15 %

FORETS | FORETS À POINTER CN HSS



HSS **h6** **N**

P M K N S H

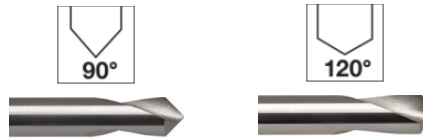

D1	L1	LONGUEUR UTILE	71175		71176	
			Code	Prix € net HT	Code	Prix € net HT
3,00	46	5,00	028907	9,05	028918	9,05
4,00	55	3,00	028908	8,91	028919	8,91
5,00	62	11,20	028909	9,23	028920	9,69
6,00	66	12,80	028910	9,54	028921	9,54
8,00	79	16,80	028911	15,86	028922	15,86
10,00	89	20,00	028912	17,85	028923	17,85
12,00	102	24,00	028913	23,88	028924	25,96
16,00	115	30,00	028914	30,75	028925	33,42
20,00	131	36,00	028915	54,15	028926	54,15
25,00	151	42,40	028916	99,70		
25,40	156	42,40	028917	103,19	028927	109,53

| DANS LA LIMITE DES STOCKS |

FORETS À PLAQUETTES | KING DRILL - KED DRILL



KING DRILL		KED DRILL		EXEMPLE PRIX KED DRILL	
CAPACITÉ	EXISTE DU Ø 12 AU Ø 60,5 INCREMENTATION 0,5	CAPACITÉ	EXISTE DU Ø 12 AU Ø 60 INCREMENTATION 0,5	E2D 32032 11	258,12
RATIO	2D 3D 4D 5D	RATIO	2D 3D 4D 5D	E3D 32032 11	258,12
				E4D 32032 11	283,95
				E5D 32032 11	411,73

10 PLAQUETTES INTER ET 10 EXTER ACHETÉES = 1 FORET A REMISE 50%

| TARIF ACTUEL EN VIGUEUR |

PLAQUETTE ALU

SPET-ND **XOET-ND**



PLAQUETTE INOX ET RÉFRACTAIRE

SPMT-LD **XOMT-LD**



PLAQUETTE UNIVERSELLE

SPMT-PD **XOMT-PD** **XOMT-RD**





HSS 5% COBALT
< 2,5 D



HSS 5% COBALT
< 2,5 D



FRITTÉ
< 3 D



FRITTÉ
< 3 D

TOLÉRANCE ENTRÉE GOUJURE		A15S TIN 6H B = 4 5 FILETS DROITE		A70S TIN 6H C = 2 3 FILETS HÉLICOÏDALE 40°		P15 TIH1 6HX B = 4 5 FILETS DROITE		P70 TIH1 6HX C = 2 3 FILETS HÉLICOÏDALE 45°	
∅	Pas	Code	Prix promo € HT	Code	Prix promo € HT	Code	Prix promo € HT	Code	Prix promo € HT
M2	x 0,40					042650	21,89	042670	21,89
M2,5	x 0,45					042651	22,07	042671	22,07
M3	x 0,50	041452	14,54	047504	12,88	042652	17,66	042672	19,32
M4	x 0,70	041453	13,43	047505	12,88	042653	18,21	042673	19,86
M5	x 0,80	041454	13,43	047506	12,88	042654	19,50	042674	20,96
M6	x 1,00	041455	13,43	047507	12,88	042655	20,61	042675	21,89
M8	x 1,25	041456	16,18	047508	12,88	042656	23,36	042676	26,30
M10	x 1,50	041457	19,86	047509	18,39	042657	30,71	042677	33,84
M12	x 1,75	041458	24,84	047510	24,84	042658	45,43	042678	50,59
M14	x 2,00	041459	41,93	047511	41,93	042659	58,68	042679	66,59
M16	x 2,00	041460	41,93	047512	41,93	042660	63,27	042680	72,84
M18	x 2,50					042661	109,38	042681	114,13
M20	x 2,50	041462	60,70	047515	60,70	042662	142,94	042682	147,25



HSS 5% COBALT



HSS 5% COBALT



HSS 5% COBALT

		A20S TiCN		A34 TiN		A61	
∅	Pas	Code	Prix promo € HT	Code	Prix promo € HT	Code	Prix promo € HT
2	64 UNF	040919	31,06	040831	27,44	047429	25,44
3	56 UNF	040920	29,88	040832	26,38	047430	23,94
4	48 UNF	040921	29,06	040833	25,50	047431	22,94
5	44 UNF	040922	29,06	040834	25,50	047432	22,94
6	40 UNF	040923	27,94	040835	24,94	047433	21,81
8	36 UNF	040924	27,94	040836	24,94	047434	21,81
10	32 UNF	040925	29,06	040837	25,69	047435	22,94
12	28 UNF	040926	31,44	040838	27,75	047436	25,69
1/4	UNF	040927	31,44	040839	27,75	047437	25,69
5/16	UNF	040928	35,56	040840	31,69	047438	26,50
3/8	UNF	040929	38,38	040841	34,56	047439	27,13
7/16	UNF	040930	48,75	040842	43,63	047440	36,19
1/2	UNF	040931	50,38	040843	45,06	047441	37,25
9/16	UNF	040932	73,00	040844	64,81	047442	56,44
5/8	UNF	040933	72,00	040845	64,56	047443	53,56
3/4	UNF	040934	112,56	040846	102,44	047444	71,81
7/8	UNF	040935	140,88	040847	127,63	047445	92,50
1"	12 UNF	040936	217,31	040848	197,81	047447	136,50



TARAUDS MACHINE VERGNANO | HSS 5% COLBALT - UNC

VERGNANO INOX | ACIER



A19S TiCN

A60S TiCN

A33 TiN

Ø	Pas	A19S TiCN		A60S TiCN		A33 TiN	
		Code	Prix promo € HT	Code	Prix promo € HT	Code	Prix promo € HT
2	56	040867	29,88	040849	30,13	040885	26,38
3	48	040868	28,69	040850	29,19	040886	25,50
4	40	040869	27,13	040851	27,31	040887	24,06
5	40	040870	27,13	040852	27,31	040888	24,06
6	32	040871	26,13	040853	26,44	040889	23,38
8	32	040872	26,13	040854	26,44	040890	23,38
10	24	040873	28,25	040855	28,44	040891	25,00
12	24	040874	28,56	040856	29,06	040892	25,38
1/4	20	040875	29,50	040857	31,44	040893	26,13
5/16	18	040876	33,50	040858	33,88	040894	30,06
3/8	16	040877	36,56	040859	37,06	040895	33,06
7/16	14	040878	45,69	040860	46,25	040896	40,94
1/2	13	040879	47,19	040861	47,75	040897	42,31
9/16	12	040880	68,56	040862	69,00	040898	61,19
5/8	11	040881	68,31	040863	68,94	040899	61,19
3/4	10	040882	106,13	040864	107,06	040900	96,95
7/8	9	040883	134,31	040865	135,56	040901	122,20
1"	8	040884	204,38	040866	204,38	040902	185,70

TARAUDS MACHINE VERGNANO | HSS FRITTÉ - G

VERGNANO INOX | ACIER



P18 TiH1

P59 TiH1

Ø	Pas	P18 TiH1		P59 TiH1	
		Code	Prix promo € HT	Code	Prix promo € HT
1/8	28F	040807	46,75	040800	47,19
1/4	19F	040808	68,25	040801	68,81
3/8	19F	040809	83,63	040802	84,38
1/2	14F	040810	141,25	040803	143,19
5/8	14F	040811	168,50	040804	170,31
3/4	14F	040812	242,69	040805	244,69
1"11	11F	040813	348,81	040806	351,69

TARAUDS MACHINE VERGNANO | P150 - P170

VERGNANO

INOX | ACIER

METRIC



P150

DIN 371 ≤ M10

DIN 376 ≥ M12

P170

DIN 371 ≤ M10

DIN 376 ≥ M12

P150



P170



Revetement
G MAXX

6HX

6HX

ød1	P	L1	L2	L3	ød2	a	Z		Code	Prix promo € HT	Code	Prix promo € HT
M3	0,5	56	10	18	3,5	2,7	3	2,5	047867	28,50	047878	31,50
M4	0,7	63	12	21	4,5	3,4	3	3,3	047868	28,50	047879	31,50
M5	0,8	70	14	25	6	4,9	3	4,2	047869	28,50	047880	31,50
M6	1	80	16	29	6	4,9	3	5	047870	28,50	047881	31,50
M8	1,25	90	18	33	8	6,2	3	6,8	047871	34,81	047882	39,13
M10	1,5	100	20	36	10	8	3	8,5	047872	43,19	047883	48,56
M12	1,75	110	24	-	9	7	3	10,2	047873	54,94	047884	61,94
M14	2	110	25	-	11	9	3	12	047874	76,38	047885	82,31
M16	2	110	28	-	12	9	3	14	047875	83,06	047886	93,75
M18	2,5	125	32	-	14	11	4	15,5	047876	114,88	047887	123,19
M20	2,5	140	32	-	16	12	4	17,5	047877	150,00	047888	158,69

TARAUDS À REFOULER VERGNANO | P900 N RED-MAXX

VERGNANO

INOX | ACIER

METRIC



6HX

C (2-3)

3xD

RH

ød1	P	L1	L2	L3	ød2	a	Z		Code	Prix promo € HT
M2	0,4	45	4	11	2,8	2,1	3	1,85	047853	48,63
M2,5	0,45	50	4,5	14	2,8	2,1	4	2,3	047854	45,81
M3	0,5	56	5	17	3,5	2,7	4	2,8	047855	40,94
M3,5	0,6	56	6	19	4	3	4	3,25	047856	40,94
M4	0,7	63	7	21	4,5	3,4	5	3,7	047857	40,94
M5	0,8	70	8	25	6	4,9	5	4,65	047858	40,95
M6	1	80	10	29	6	4,9	5	5,6	047859	40,94
M7	1	80	10	29	7	5,5	5	6,6	047860	40,94
M8	1,25	90	13	35	8	6,2	5	7,45	047861	62,25
M10	1,5	100	15	39	10	8	6	9,35	047862	51,44
M12	1,75	110	18	-	9	7	8	11,25	047863	65,00
M14	2	110	20	-	11	9	8	13,1	047864	103,50
M16	2	110	20	-	12	9	8	15,1	047865	129,06
M20	2,5	140	25	-	16	12	8	18,9	047866	227,63

DIN 2174 (371)
≤ M10

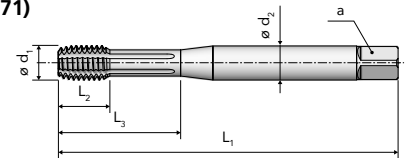

DIN 2174 (376)
≥ M12

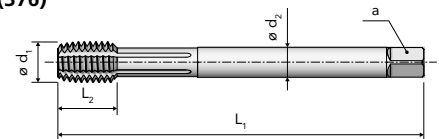

TARAUDS À REFOULER VERGNANO | HSSK FRITTÉ - M



INOX | ACIER



< 1,5 D



AVEC GOJJURE DE LUBRIFICATION

< 3 D



< 1,5 D

TOLÉRANCE ENTRÉE		P80 TIN 6HX C = 2 3 FILETS		P80N TIN 6HX C = 2 3 FILETS		P80 V MAXX 6HX C = 2 3 FILETS	
∅	Pas	Code	Prix promo € HT	Code	Prix promo € HT	Code	Prix promo € HT
M2	x 0,40	042592	36,81	042608	39,50	047841	41,13
M2,5	x 0,45	042593	34,75	042609	37,31	047842	38,81
M3	x 0,50	042594	31,06	042610	33,31	047843	34,75
M3,5	x 0,60	042595	31,06	042611	33,31	047844	34,75
M4	x 0,70	042596	31,06	042612	33,31	047845	34,75
M5	x 0,80	042597	31,06	042613	33,31	047846	34,75
M6	x 1,00	042598	31,06	042614	33,31	047847	34,75
M8	x 1,25	042599	39,13	042615	41,88	047848	43,75
M10	x 1,50	042600	49,63	042616	52,88	047849	55,31
M12	x 1,75	042601	58,69	042617	62,81	047850	65,50
M14	x 2,00	042602	78,88	042618	84,19	047851	88,19
M16	x 2,00	042603	98,19	042619	105,13	047852	109,50
M18	x 2,50			042620	164,44		
M20	x 2,50			042621	217,50		

TARAUDS MACHINE BASS | INOX | ACIER | TITANE



INOX | ACIER | ALUMINIUM



VARIANT 1 VA



DOMINANT 1 VA45



TARAUDS INOX ACIER ALU.	Code	Prix promo € net HT	TARAUDS INOX ACIER ALU.	Code	Prix promo € net HT
TAR BASS GUN 14.2311 REV HL M3	043035	26,48	TAR BASS TH 16.6141 REV HL M3	043020	29,94
TAR BASS GUN 14.2311 REV HL M4	043036	27,69	TAR BASS TH 16.6141 REV HL M4	043021	29,94
TAR BASS GUN 14.2311 REV HL M5	043037	29,77	TAR BASS TH 16.6141 REV HL M5	043022	31,15
TAR BASS GUN 14.2311 REV HL M6	043038	30,12	TAR BASS TH 16.6141 REV HL M6	043023	32,19
TAR BASS GUN 14.2311 REV HL M8	043039	37,04	TAR BASS TH 16.6141 REV HL M8	043024	40,15
TAR BASS GUN 14.2311 REVHL M10	043040	41,88	TAR BASS TH 16.6141 REV HL M10	043025	46,04
TAR BASS GUN 14.2411 REVHL M12	043041	56,42	TAR BASS TH 16.6241 REV HL M12	043026	61,62
TAR BASS GUN 14.2411 REVHL M16	043042	74,08	TAR BASS TH 16.6241 REV HL M14	043027	78,92
TAR BASS GUN 14.2411 REVHL M20	043043	114,23	TAR BASS TH 16.6241 REV HL M16	043028	85,15
			TAR BASS TH 16.6241 REV HL M20	043029	126,00

- HSSE PM
- ENTRÉE : B (3,5 - 5)
- REVÊTEMENT : TIALN
- GOJJURE : DROITE

- HSSE PM
- ENTRÉE : C (2 -3)
- REVÊTEMENT : TIALN
- GOJJURE : HÉLICOÏDALE 45°

TARAUDS MACHINE BASS | INOX | ACIER | TITANE

BASS
TECHNIK FÜR GEWINDE

TITANE | INOX



VARIANT 1 TIH



AVANT 1 TIH13



TARAUDS TITANE ACIER	Code	Prix promo € net HT
TAR BASS GUN 25.2311 M3 TICN	043060	31,50
TAR BASS GUN 25.2311 M4 TICN	043061	32,19
TAR BASS GUN 25.2311 M5 TICN	043062	35,65
TAR BASS GUN 25.2311 M6 TICN	043063	37,04
TAR BASS GUN 25.2311 M8 TICN	043064	43,27
TAR BASS GUN 25.2311 M10 TICN	043065	51,23
TAR BASS GUN 25.2411 M12 TICN	043066	67,50

- HSSE PM
- ENTRÉE : B (3,5 - 5)
- REVÊTEMENT : TICN
- GOUJURE : DROITE

TARAUDS TITANE ACIER	Code	Prix promo € net HT
TAR BASS TH 25.2131 M3 TICN	043050	32,02
TAR BASS TH 25.2131 M4 TICN	043051	32,88
TAR BASS TH 25.2131 M5 TICN	043052	35,65
TAR BASS TH 25.2131 M6 TICN	043053	35,65
TAR BASS TH 25.2131 M8 TICN	043054	43,27
TAR BASS TH 25.2131 M10 TICN	043055	49,85
TAR BASS TH 25.2231 M12 TICN	043056	69,23

- HSSE PM
- ENTRÉE : C (2 -3)
- REVÊTEMENT : TICN
- GOUJURE : HÉLICOÏDALE 13°

TARAUDS MACHINE BASS | MJ | UNJ

BASS
TECHNIK FÜR GEWINDE

TITANE | INOX



VARIANT TIH TICN



Type	Éxecution	Pas	Diam.	Pas	Code	Prix promo € net HT
VARIANT 1 TIH	TICN	MJ	4	0,70	043069	57,46
VARIANT 1 TIH	TICN	MJ	5	0,80	043070	63,69
VARIANT 1 TIH	TICN	MJ	6	1,00	043071	65,42
VARIANT 1 TIH	TICN	MJ	8	1,25	043087	77,54
VARIANT 1 TIH	TICN	MJ	10	1,50	043088	92,77
VARIANT 1 TIH	TICN	UNJC	No6	32	043089	47,08
VARIANT 1 TIH	TICN	UNJC	No8	32	043072	47,77
VARIANT 1 TIH	TICN	UNJC	No10	24	043073	51,58
VARIANT 1 TIH	TICN	UNJC	1/4"	20	043074	53,65
VARIANT 1 TIH	TICN	UNJC	5/16"	18	043090	63,00
VARIANT 1 TIH	TICN	UNJC	3/8"	16	043091	74,08
VARIANT 1 TIH	TICN	UNJF	No6	40	043092	49,85
VARIANT 1 TIH	TICN	UNJF	No8	36	043075	50,19
VARIANT 1 TIH	TICN	UNJF	No10	32	043076	54,69
VARIANT 1 TIH	TICN	UNJF	1/4"	28	043077	57,12
VARIANT 1 TIH	TICN	UNJF	5/16"	24	043093	67,85
VARIANT 1 TIH	TICN	UNJF	3/8"	24	043094	78,92

TARAUDS MACHINE BASS | LONGS TROUS BORGNES

BASS
TECHNIK FÜR GEWINDE

TITANE | INOX | ACIER | ALUMINIUM

NOUVEAUTÉ



DOMINANT 1 LT45 TIN SL



Type	Lt	Référence	Prix tarif € net HT
DOMINANT 1 LT45 TIN SL M 3	100	780168	46,75
DOMINANT 1 LT45 TIN SL M 4	125	780169	46,75
DOMINANT 2 LT45 TIN SL M 4	125	780178	63,50
DOMINANT 1 LT45 TIN SL M 5	160	780170	48,25
DOMINANT 2 LT45 TIN SL M 5	160	780179	78,00
DOMINANT 1 LT45 TIN SL M 6	160	780171	49,50
DOMINANT 2 LT45 TIN SL M 6	160	780180	87,00
DOMINANT 1 LT45 TIN SL M 8	180	780172	59,50
DOMINANT 2 LT45 TIN SL M 8	180	780181	95,00
DOMINANT 1 LT45 TIN SL M 10	200	780173	69,50
DOMINANT 2 LT45 TIN SL M 10	200	780182	113,00
DOMINANT 2 LT45 TIN SL M 12	200	780174	90,00
DOMINANT 2 LT45 TIN SL M 14	200	780175	110,00
DOMINANT 2 LT45 TIN SL M 16	200	780176	127,00
DOMINANT 2 LT45 TIN SL M 20	200	780177	202,00

DOMINANT 1 LT45 TIN



Type	Lt	Référence	Prix tarif € net HT
DOMINANT 1 LT45 TIN M 2	50	780303	40,25
DOMINANT 1 LT45 TIN M 2,5	56	780304	32,75
DOMINANT 1 LT45 TIN M 3	63	780305	28,25
DOMINANT 1 LT45 TIN M 4	70	780306	28,25
DOMINANT 1 LT45 TIN M 5	80	780307	29,75
DOMINANT 1 LT45 TIN M 6	90	780308	36,25
DOMINANT 1 LT45 TIN M 8	100	780309	40,50
DOMINANT 2 LT45 TIN M 10	100	780310	56,50
DOMINANT 2 LT45 TIN M 12	110	780311	57,50
DOMINANT 2 LT45 TIN M 16	125	780312	84,00
DOMINANT 2 LT45 TIN M 20	160	780313	124,00

TARAUDS MACHINE BASS | LONGS TROUS DÉBOUCHANTS

BASS
TECHNIK FÜR GEWINDE

TITANE | INOX | ACIER | ALUMINIUM

NOUVEAUTÉ



VARIANT 1 LT TIN SL



Type	Lt	Référence	Prix tarif € net HT
VARIANT 1 LT TIN SL M 3	100	780065	46,25
VARIANT 1 LT TIN SL M 4	125	780066	45,50
VARIANT 2 LT TIN SL M 4	125	780075	48,50
VARIANT 1 LT TIN SL M 5	160	780067	47,75
VARIANT 2 LT TIN SL M 5	160	780076	52,50
VARIANT 1 LT TIN SL M 6	160	780068	49,25
VARIANT 2 LT TIN SL M 6	160	780077	63,50
VARIANT 1 LT TIN SL M 8	180	780069	59,50
VARIANT 2 LT TIN SL M 8	180	780078	72,50
VARIANT 1 LT TIN SL M 10	200	780070	67,50
VARIANT 2 LT TIN SL M 10	200	780079	81,00
VARIANT 2 LT TIN SL M 12	200	780071	93,50
VARIANT 2 LT TIN SL M 14	200	780072	114,00
VARIANT 2 LT TIN SL M 16	200	780073	124,00
VARIANT 2 LT TIN SL M 20	200	780074	183,00

VARIANT 1 LT TIN



Type	Lt	Référence	Prix tarif € net HT
VARIANT 1 LT TIN M 2	50	780292	40,25
VARIANT 1 LT TIN M 2,5	56	780293	32,50
VARIANT 1 LT TIN M 3	63	780294	26,75
VARIANT 1 LT TIN M 4	70	780295	27,00
VARIANT 1 LT TIN M 5	80	780296	28,50
VARIANT 1 LT TIN M 6	90	780297	34,75
VARIANT 1 LT TIN M 8	100	780298	38,75
VARIANT 2 LT TIN M 10	100	780299	53,50
VARIANT 2 LT TIN M 12	110	780300	54,50
VARIANT 2 LT TIN M 16	125	780301	80,00
VARIANT 2 LT TIN M 20	160	780302	107,00

TITANE | INOX

AVANT TIH13 TICN



Type	Exécution	Pas	Diam.	Pas	Code	Prix promo € net HT
AVANT 1 TIH13	TICN	MJ	4	0,70	043095	54,69
AVANT 1 TIH13	TICN	MJ	5	0,80	043078	60,58
AVANT 1 TIH13	TICN	MJ	6	1,00	043079	62,65
AVANT 1 TIH13	TICN	MJ	8	1,25	043080	74,77
AVANT 1 TIH13	TICN	MJ	10	1,50	043096	86,54
AVANT 1 TIH13	TICN	UNJC	No6	32	043097	44,65
AVANT 1 TIH13	TICN	UNJC	No8	32	043098	45,00
AVANT 1 TIH13	TICN	UNJC	No10	24	043081	49,15
AVANT 1 TIH13	TICN	UNJC	1/4"	20	043082	50,19
AVANT 1 TIH13	TICN	UNJC	5/16"	18	043083	60,58
AVANT 1 TIH13	TICN	UNJC	3/8"	16	043099	70,62
AVANT 1 TIH13	TICN	UNJF	No6	40	043100	47,77
AVANT 1 TIH13	TICN	UNJF	No8	36	043101	48,46
AVANT 1 TIH13	TICN	UNJF	No10	32	043084	50,19
AVANT 1 TIH13	TICN	UNJF	1/4"	28	043085	54,00
AVANT 1 TIH13	TICN	UNJF	5/16"	24	043086	63,69
AVANT 1 TIH13	TICN	UNJF	3/8"	24	043102	74,77

TARAUDS MACHINE BASS | SMARTLINE

INOX | ACIER | ALUMINIUM



VARIANT H VAP



TARAUDS INOX ACIER	Code	Prix promo € net HT
TAR BASS LP GUN VAP M3	043010	15,19
TAR BASS LP GUN VAP M4	043011	15,77
TAR BASS LP GUN VAP M5	043012	17,12
TAR BASS LP GUN VAP M6	043013	17,12
TAR BASS LP GUN VAP M8	043014	19,62
TAR BASS LP GUN VAP M10	043015	23,65
TAR BASS LP GUN VAP M12	043016	27,31
TAR BASS LP GUN VAP M14	043019	35,58
TAR BASS LP GUN VAP M16	043017	39,23
TAR BASS LP GUN VAP M20	043018	60,77

- HSSE PM
- ENTRÉE : B (3,5 - 5,4)
- REVÊTEMENT : VAP
- TROU DÉBOUCHANT

DOMINANT HZ38 VAP



TARAUDS INOX ACIER	Code	Prix promo € net HT
TAR BASS LP TH VAP M3	043001	15,96
TAR BASS LP TH VAP M4	043002	16,73
TAR BASS LP TH VAP M5	043003	17,69
TAR BASS LP TH VAP M6	043004	17,69
TAR BASS LP TH VAP M8	043005	20,38
TAR BASS LP TH VAP M10	043006	24,42
TAR BASS LP TH VAP M12	043007	28,08
TAR BASS LP TH VAP M14	043031	33,65
TAR BASS LP TH VAP M16	043008	40,38
TAR BASS LP TH VAP M20	043009	55,38

- HSSE PM
- ENTRÉE : C (2 - 3)
- REVÊTEMENT : VAP
- TROU BORGNE

LUBRIFIANT

LUBRIFIANT	Articles	Code	Prix tarif € HT
RTD SPRAY LUBRIFIANT AEROSOL 400 ML	R53011	049002	30,54
RTD PÂTE LUBRIFIANTE POT 500G	R53023	049003	21,28
RTD LUBRIFIANT LIQUIDE BURETTE 400G	R53072	049004	30,54
RTD 5 LITRES LIQUIDE	R53076	049006	287,49



TARAUDS MACHINE

TARAUDS CARBURE



TARAUD FANAR CARBURE TiCN HRC60			Code	Prix promo € HT	TARAUD VERGNANO CARBURE V MAXX H130			Code	Prix promo € HT
C9	135F01	0030	M3	045700	57,92	A000301309A1AV0	M3x0,5	042729	169,56
C9	135F01	0040	M4	045701	59,76	A000401309A1AV0	M4x0,7	042730	169,56
C9	135F01	0050	M5	045702	61,53	A000501309A1AV0	M5,08	042731	171,88
C9	135F01	0060	M6	045703	68,77	A000601309A1AV0	M6x1,00	042732	174,00
C9	135F01	0080	M8	045704	83,25	A000801309A1AV0	M8x1,25	042733	198,19
						A001001309A1AV0	M10x1,5	042734	219,56
						A001201309A1AV0	M12x1,75	042735	277,19

- HRC 60
- REVÊTEMENT : TiCN
- GOUJURE : DROITE

- H130
- REVÊTEMENT : V MAXX
- GOUJURE : DROITE

BRAS DE TARAUDAGE ÉLECTRIQUE



À PARTIR DE
1 199
€ HT*

Modèle	GS 1100-16 E	GS 1200-24 E	GS 1200-36 E
Puissance moteur	0.6 kW / 230 V ~ 50Hz	1.2 kW / 230 V ~ 50Hz	
Entraînement	Electrique	Electrique	Electrique
Taraudage à 400 N / mm ²	M3 - M16	M6 - M24	M6 - M36
Vitesse	312 T/min	250 T/min	156 T/min
Rayon d'action	1100 mm	1200 mm	
Angle	0 - 90°	0 - 90°	0 - 90°
Dimension (L x l x h)	930 x 90 x 520 mm	1400 x 100 x 700 mm	1400 x 100 x 700 mm
Poids net (brut)	25 kg (32 kg)	45 kg (52 kg)	50 kg (61 kg)
Code	0450005	0450006	0450007
Prix	1 199 € HT*	1 569 € HT*	1 599 € HT*

Le saviez-vous ?

Nous vendons aussi
le socle
Code : 0450008

1 099
€ HT*



| SOUS RÉSERVE DE HAUSSE TARIFAIRE |



PORTE-OUTILS AKKO | TOURNAGE EXTÉRIEUR

PORTE - OUTILS A LEVIER TYPE P



Utilisations	Carre
POUR PLAQUETTES TYPE CN.../WN.../TN...	CARRE 20
POUR PLAQUETTES TYPE CN.../WN.../TN...	CARRE 25
POUR PLAQUETTES DN	CARRE 20
POUR PLAQUETTES DN	CARRE 25

Désignation	Référence	Code
PCLNR 2020 K12C	M.01.01.04.01.02	098285
PCLNL 2020 K12C	M.01.01.04.02.02	098286
PDJNR 2020 K15C	M.01.01.04.05.04	098287
PDJNL 2020 K15C	M.01.01.04.06.05	098288
PWLN 2020 K08C	M.01.01.04.17.02	098289
PWLN 2020 K06	M.01.01.04.17.07	098290
PWLN 2020 K08C	M.01.01.04.18.02	098291
PWLN 2020 K06	M.01.01.04.18.07	098292
PCLNR 2525 M12C	M.01.01.04.01.03	098293
PCLNL 2525 M12C	M.01.01.04.02.03	098294
PDJNR 2525 M15C	M.01.01.04.05.05	098295
PDJNL 2525 M11	M.01.01.04.06.04	098296
PDJNL 2525 M15C	M.01.01.04.06.06	098297
PWLN 2525 M08C	M.01.01.04.17.03	098298
PWLN 2525 M06	M.01.01.04.17.06	098299
PWLN 2525 M08C	M.01.01.04.18.03	098300
PWLN 2525 M06	M.01.01.04.18.06	098301

**41€
HT**

PORTE-OUTILS | TOURNAGE INTÉRIEUR



Longueurs

H = 100	R = 200
K = 125	S = 250
M = 150	T = 300
P = 170	U = 350



Porte-outils intérieur	Référence	Code	Prix promo € HT
S08H SCLCL 06	M.01.02.03.10.01	098302	20,30
S10K SCLCL 06	M.01.02.03.10.02	098303	23,10
S12K SCLCL 06	M.01.02.03.10.03	098304	24,50
S12K SCLCL 09	M.01.02.03.10.28	098305	24,50
S16P SCLCL 09	M.01.02.03.10.07	098306	28,00
S16P SCLCL 06	M.01.02.03.10.29	098307	28,00
S20R SCLCL 09	M.01.02.03.10.08	098308	29,40
S25S SCLCL 09	M.01.02.03.10.10	098309	39,20
S25S SCLCL 12	M.01.02.03.10.18	098310	39,20
S32T SCLCL 09	M.01.02.03.10.11	098311	59,50
S32T SCLCL 12	M.01.02.03.10.19	098312	59,50
S08H SCLCR 06	M.01.02.03.09.01	098313	20,30
S10K SCLCR 06	M.01.02.03.09.02	098314	23,10
S12K SCLCR 06	M.01.02.03.09.03	098315	24,50
S12K SCLCR 09	M.01.02.03.09.27	098316	24,50
S16P SCLCR 09	M.01.02.03.09.07	098317	28,00
S16P SCLCR 06	M.01.02.03.09.28	098318	28,00
S20R SCLCR 09	M.01.02.03.09.08	098319	29,40
S25S SCLCR 09	M.01.02.03.09.10	098320	39,20
S25S SCLCR 12	M.01.02.03.09.18	098321	39,20
S32T SCLCR 09	M.01.02.03.09.11	098322	59,50
S32T SCLCR 12	M.01.02.03.09.19	098323	59,50

Porte-outils intérieur	Référence	Code	Prix promo € HT
A08H SCLCL 06	M.01.02.03.10.04	098324	24,50
A10H SCLCL 06	M.01.02.03.10.05	098325	27,30
A12H SCLCL 06	M.01.02.03.10.06	098326	29,40
A16M SCLCL 09	M.01.02.03.10.12	098327	35,00
A20P SCLCL 09	M.01.02.03.10.13	098328	35,70
A25R SCLCL 09	M.01.02.03.10.15	098329	49,70
A25R SCLCL 12	M.01.02.03.10.22	098330	49,70
A32S SCLCL 09	M.01.02.03.10.16	098331	75,60
A08H SCLCR 06	M.01.02.03.09.04	098332	24,50
A10H SCLCR 06	M.01.02.03.09.05	098333	27,30
A12H SCLCR 06	M.01.02.03.09.06	098334	29,40
A16M SCLCR 09	M.01.02.03.09.12	098335	35,00
A20P SCLCR 09	M.01.02.03.09.13	098336	35,70
A25R SCLCR 09	M.01.02.03.09.15	098337	49,70
A25R SCLCR 12	M.01.02.03.09.22	098338	49,70
A32S SCLCR 09	M.01.02.03.09.16	098339	75,60

PORTE-OUTILS AKKO | TOURNAGE INTÉRIEUR



KAPR=93°

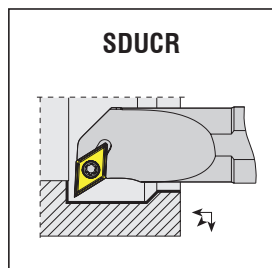

SDUCR

Longueurs

H = 100 R = 200
K = 125 S = 250
M = 150 T = 300
P = 170 U = 350



KAPR=117.5°

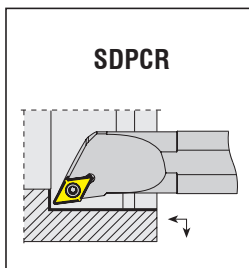

SDPCR



KAPR=95°

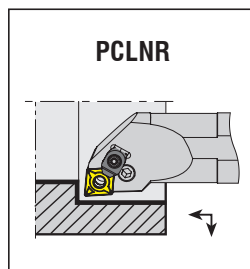

PCLNR

Porte-outils intérieur	Référence	Code	Prix promo € HT
A10H SDUCL 07	M.01.02.03.02.05	098340	27,30
A12H SDUCL 07	M.01.02.03.02.06	098341	29,40
A16M SDUCL 07	M.01.02.03.02.07	098342	35,00
A16M SDUCL 11	M.01.02.03.02.15	098343	35,00
A20P SDUCL 07	M.01.02.03.02.08	098344	35,70
A20P SDUCL 11	M.01.02.03.02.16	098345	35,70
A25R SDUCL 11	M.01.02.03.02.17	098346	49,70
A32S SDUCL 11	M.01.02.03.02.18	098347	75,60
A10H SDUCR 07	M.01.02.03.01.05	098348	27,30
A12H SDUCR 07	M.01.02.03.01.06	098349	29,40
A16M SDUCR 11	M.01.02.03.01.12	098350	35,00
A16M SDUCR 07	M.01.02.03.01.16	098351	35,00
A20P SDUCR 11	M.01.02.03.01.13	098352	35,70
A20P SDUCR 07	M.01.02.03.01.27	098353	35,70
A25R SDUCR 11	M.01.02.03.01.14	098354	49,70
A25T SDUCR 11	M.01.02.03.01.54	098355	93,80
A32S SDUCR 11	M.01.02.03.01.15	098356	75,60

Porte-outils intérieur	Référence	Code	Prix promo € HT
S10K SDPCL 07	M.01.02.03.44.04	098357	23,10
S12K SDPCL 07	M.01.02.03.44.01	098358	24,50
S16P SDPCL 11	M.01.02.03.44.02	098359	28,00
S20R SDPCL 11	M.01.02.03.44.03	098360	29,40
S25S SDPCL 11	M.01.02.03.44.05	098361	39,20
S10K SDPCR 07	M.01.02.03.41.03	098362	23,10
S12K SDPCR 07	M.01.02.03.41.02	098363	24,50
S16P SDPCR 11	M.01.02.03.41.04	098364	28,00
S20R SDPCR 11	M.01.02.03.41.01	098365	29,40
S25S SDPCR 11	M.01.02.03.41.05	098366	39,20

Porte-outils intérieur	Référence	Code	Prix promo € HT
A20P PCLNL 09	M.01.02.04.02.30	098367	58,10
A25R PCLNL 12C	M.01.02.04.02.05	098368	70,00
A32S PCLNL 12C	M.01.02.04.02.06	098369	84,00
A32T PCLNL 12	M.01.02.04.01.30	098370	100,10
A40T PCLNL 12C	M.01.02.04.02.07	098371	110,60
A50U PCLNL 12C	M.01.02.04.02.16	098372	134,40
A20P PCLNR 09	M.01.02.04.01.29	098373	58,10
A25R PCLNR 12C	M.01.02.04.01.05	098374	70,00
A25S PCLNR 12C	M.01.02.04.01.17	098375	78,40
A32S PCLNR 12C	M.01.02.04.01.06	098376	84,00
A40T PCLNR 12C	M.01.02.04.01.07	098377	110,60
A50U PCLNR 12C	M.01.02.04.01.20	098378	134,40

KITS BARRE D'ALÉSAGE

Diamètre 8-10-12-16

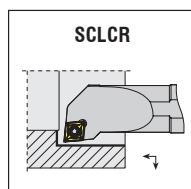

SCLCR



Désignation	Référence	Code	Prix promo € HT
SET-S/SCLCR	M.01.02.03.54.03	098379	101,98
SET-S/SCLCL	M.01.02.03.54.10	098380	101,98
SET-A/SCLCR	M.01.02.03.54.01	098381	118,88
SET-A/SCLCL	M.01.02.03.54.08	098382	118,88
SET-E/SCLCR	M.01.02.03.54.02	098383	668,02
SET-E/SCLCL	M.01.02.03.54.09	098384	668,02

PORTE-OUTILS AKKO

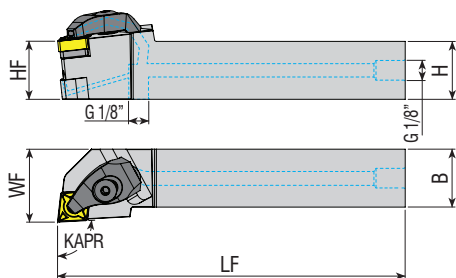

KAPR=95°
TCLN

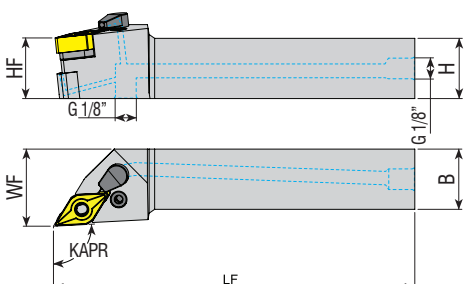
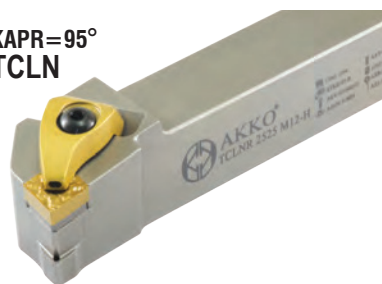

KAPR=93°
PDJN

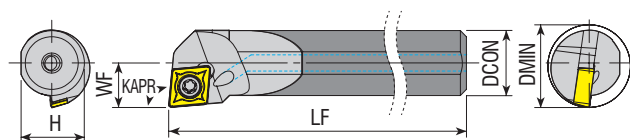
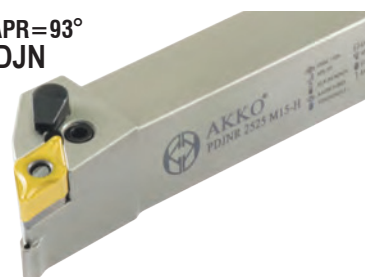

KAPR=95°



Référence	HF=H	B	LF	WF	Code R	Code L	Prix promo € HT
TCLNR/L 2020 K12-H	20	20	125	25	098006	098007	109,90
TCLNR/L 2525 M12-H	25	25	150	32	098008	098009	112,00
TCLNR/L 3232 P12-H	32	32	170	40	098010	098011	127,40
TDJNR/L 2020 K15-H	20	20	125	25	098012	098013	109,90
TDJNR/L 2525 M15-H	25	25	150	32	098014	098015	112,00
TDJNR/L 3232 P15-H	32	32	170	40	098016	098017	127,40
TDNNN 2525 M15-H	25	25	150	32	098018		112,00
TSDNN 2525 M12-H	25	25	150	25	098019		112,00
TSDNN 3232 P12-H	32	32	170	16	098020		127,40
TSDNN 2525 M15-H	25	25	150	12,7	098021		112,00
TSDNN 3232 P15-H	32	32	170	16	098022		127,40
TSDNN 4040 S15-H	40	40	250	20	098023		205,10
TSSNR/L 2525 M12-H	25	25	150	32	098024	098025	112,00
TSSNR/L 3232 P12-H	32	32	170	32	098026	098027	127,40
TSSNR/L 2525 M15-H	25	25	150	40	098028	098029	112,00
TSSNR/L 3232 P15-H	32	32	170	40	098030	098031	127,40
TSSNR/L 4040 S15-H	40	40	250	50	098032	098033	205,10
TTJNR/L 2525 M16-H	25	25	150	32	098034	098035	112,00
TTJNR/L 3232 P16-H	32	32	170	32	098036	098037	127,40
TTJNR/L 2525 M22-H	25	25	150	40	098038	-	112,00
TTJNR/L 3232 P22-H	32	32	170	40	098039	098040	127,40
TVVNN 2020 K16-H	20	20	125	10	098041		109,90
TVVNN 2525 M16-H	25	25	150	12,7	098042		112,00
TWLNR/L 2020 K08-H	20	20	125	25	098043	098044	109,90
TWLNR/L 2525 M08-H	25	25	150	32	098045	098046	112,00
TWLNR/L 3232 P08-H	32	32	170	40	098047	098048	127,40

Référence	HF=H	B	LF	WF	Code R	Code L	Prix promo € HT
PCLNR/L 2020 K12-H	20	20	125	25	098049	098057	81,20
PCLNR/L 2525 M12-H	25	25	150	32	098051	098059	83,30
PCLNR/L 3232 P12-H	32	32	170	40	098053	098061	94,50
PCLNR/L 3232 P16-H	32	32	170	40	098055	-	94,50
PCLNR/L 3232 P19-H	32	32	170	40	098056	-	118,30
PDJNR/L 2020 K15-H	20	20	125	25	098050	098058	81,20
PDJNR/L 2525 M15-H	25	25	150	32	098052	098060	83,30
PDJNR/L 3232 P15-H	32	32	170	40	098054	098062	94,50
PDNNN 2525 M15-H	25	25	150	32	098063		83,30
PWLNR/L 2020 K08-H	20	20	125	25	098064	098065	81,20
PWLNR/L 2525 M08-H	25	25	150	32	098066	098067	83,30

Référence	DCON	H	LF	WF	DMIN	Code R	Code L	Prix promo € HT
C04G SCLCR/L 03	4	3,7	90	2,5	≥5	098068	-	73,50
C05H SCLCR/L 03	5	4,7	100	3	≥6	098069	-	81,20
C06J SCLCR/L 04	6	5,7	110	3,5	≥7	098070	-	88,90
C07K SCLCR/L 04	7	6,7	125	4	≥8	098071	-	98,70
C06J SCLCR/L 06	6	5,7	110	4,5	≥8	098072	098073	97,30
E08K SCLCR/L 06	8	7,5	125	6	≥11	098074	098075	108,50
E10M SCLCR/L 06	10	9,5	150	7	≥13	098076	098077	156,80
E12Q SCLCR/L 06	12	11	180	9	≥16	098078	098079	221,90
E16R SCLCR/L 09	16	15	200	11	≥20	098080	098081	262,50
E20S SCLCR/L 09	20	19	250	13	≥24	098082	098083	504,70

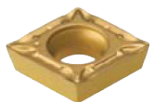

PLAQUETTES	Code	Prix promo € net HT
CCET 030102L PC9030	079208	8,63
CCET 0301005L PC9030	079209*	8,63
CCET 040102L PC9030	079210	8,63
CCET 0401005L PC9030	079211*	8,63



| DANS LA LIMITE DES STOCKS DISPONIBLES |

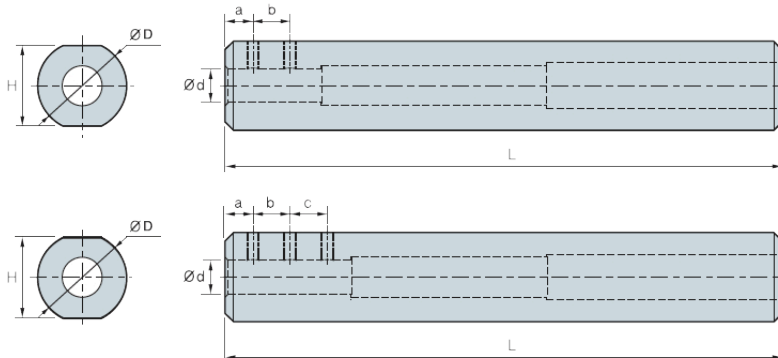

PORTE BARRE ALESAGE MINI - SL160...

D = diamètre mini
d = diamètre outil

Ø d	a	b	c	Ø D	H	L	VIS	CLE	MANCHON	Code	Prix promo € net HT
4	5	6		16	14	100	M4	HW20L	SL1604	090110	93,67
5	5	8		16	14	100	M4	HW20L	SL1605	090111	93,67
6	5	6	6	16	14	100	M4	HW20L	SL1606	090112	93,67

GORGES ET TRONÇONNAGE AKKO

Plaquettes compatibles MGM

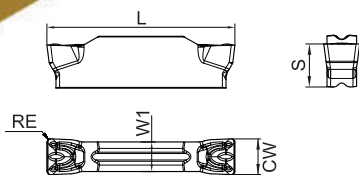
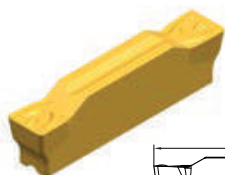

Référence	CW±0.05	RE±0.05	L	W1	S	AP1225		AA4230	
						Code	Prix promo € HT	Code	Prix promo € HT
AGD2002-MT	2.0	0.2	16.0	1.2	3.5	098236	8,00	098239	8,00
AGD3004-MT	3.0	0.4	21.2	2.35	4.8	098237	8,80	098240	8,80
AGD4004-MT	4.0	0.4	21.0	3.3	4.8	098238	9,60	098241	9,60

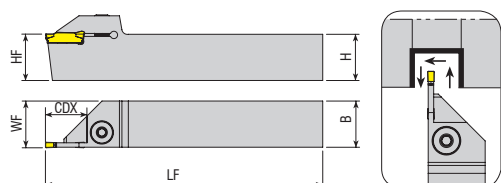

Référence	HF=H	B	LF	WF	CDX	Code R	Code L	Prix promo € HT
ADKT-K-R/L-2020-2-T15	20	20	150	20,3	15	098242	098243	68,00
ADKT-K-R/L-2525-2-T15	25	25	150	25,3	15	098244	098245	68,80
ADKT-K-R/L-2020-3-T20	20	20	125	20,3	20	098246	098247	68,00
ADKT-K-R/L-2020-3-R28	20	20	125	20,3	28	098248	098249	88,80
ADKT-K-R/L-2020-4-T20	20	20	125	20,4	20	098250	098251	68,00
ADKT-K-R/L-2020-4-R25	20	20	125	20,4	25	098252	098253	81,60
ADKT-K-R/L-2525-4-T22	25	25	150	25,4	22	098254	098255	68,80
ADKT-K-R/L-2525-3-T22	25	25	150	25,3	22	098385	098386	60,20



R390.11T3

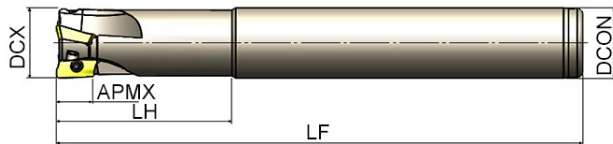

R390.1704

R390.1806

AEM.90-R390

DC	ZEFP	DCON	LF	LH	APMX	Articles	Prix tarif € net HT
12	1	12	100	25	10	M.32.10	98,40
16	2	16	100	30	10	M.06.10.03	109,70
16	2	16	150	50	10	M.06.10.19	109,70
16	2	16	150	50	10	M.06.10.13	128,20
20	2	20	90	30	10	M.06.10.17	104,60
20	3	20	100	30	10	M.06.10.11	128,20
20	3	20	150	50	10	M.06.10.05	128,20
20	3	20	150	50	10	M.06.10.08	145,60
20	3	20	150	30	10	M.06.10.20	128,20
22	2	20	90	30	10	M.06.10.18	104,60
25	3	20	150	40	10	M.06.10.21	128,20
25	3	25	100	30	10	M.06.10.09	128,20
25	3	25	150	50	10	M.06.10.07	128,20
25	3	25	150	50	10	M.06.10.10	145,60
30	4	25	150	30	10	M.06.10.15	177,40
32	3	25	200	40	10	M.06.10.22	196,80
32	5	32	150	50	10	M.06.10.16	197,90
25	2	25	150	50	15,4	M.06.10.01	128,20
25	2	25	150	50	15,4	M.06.10.14	145,60
30	3	25	150	40	15,4	M.06.10.02	145,60
30	3	25	150	40	15,4	M.06.10.12	169,20
32	3	32	150	40	15,4	M.06.10.25	169,20
32	3	32	150	45	15,4	M.06.10.23	145,60
40	4	32	150	40	15,4	M.06.10.26	209,10



XO..0602

XO..0903

XO..10T3

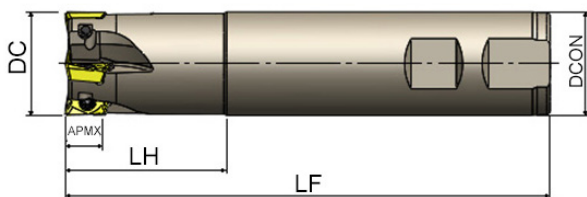

XO..1204

AEM.90.XO

DC	ZEFP	DCON	LF	LH	APMX	Articles	Prix tarif € net HT
10	2	10	100	15	5	M.06.01.04.27	193,80
10	2	12	120	50	5	M.06.01.04.05	161,00
12	2	12	120	25	5	M.06.01.04.06	161,00
12	2	12	120	15	5	M.06.01.04.22	193,80
16	2	16	15	50	8	M.06.01.04.08	122,00
20	3	20	15	50	8	M.06.01.04.07	137,40
16	2	16	170	50	8	M.06.01.04.23	213,20
20	3	20	170	30	8	M.06.01.04.25	238,90
20	3	19	170	30	9	M.06.01.04.26	238,90
20	3	20	170	50	9	M.06.01.04.28	238,90
20	2	20	150	50	11	M.06.01.04.01	109,70
20	2	20	200	100	11	M.06.01.04.14	169,20
22	2	20	150	30	11	M.06.01.04.02	109,70
25	3	25	150	50	11	M.06.01.04.03	122,00
25	3	25	170	100	11	M.06.01.04.24	251,20
25	3	25	200	100	11	M.06.01.04.15	186,60
32	4	25	150	40	11	M.06.01.04.13	140,50
32	4	32	150	50	11	M.06.01.04.04	140,50
32	4	32	250	100	11	M.06.01.04.09	362,90

PORTE-OUTILS AKKO

Plaquettes compatibles
R390..

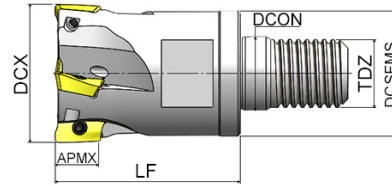
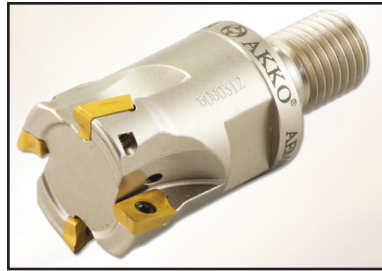

R390.11T3	DC	ZEP	DCSFMS	TDZ	LF	DCON	APMX	Articles	Prix tarif € net HT
	16	2	14,75	M08	30	8,5	10	M.06.11.06.03	134,30
20	3	18	M10	30	10,5	10	M.06.11.06.02	155,80	
25	3	21	M12	35	12,5	10	M.06.11.06.01	162,00	
32	4	29	M16	43	17	10	M.06.11.06.04	175,30	

Plaquettes compatibles
R390..

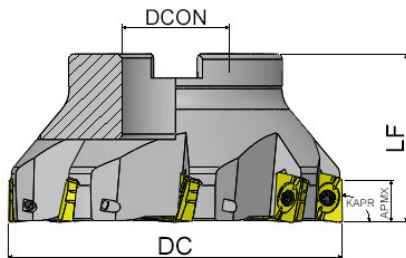

R390.11T3

R390.1704

R390.1806

DC	ZEP	DCON	LF	APMX	Articles	Prix tarif € net HT
40	5	16	40	10	M.06.02.22.07	129,20
50	6	22	40	10	M.06.02.22.08	154,80
63	7	22	40	10	M.06.02.22.09	177,40
80	9	27	50	10	M.06.02.22.10	231,70
40	4	16	40	15,4	M.06.02.22.01	129,20
50	5	22	40	15,4	M.06.02.22.02	154,80
63	6	22	40	15,4	M.06.02.22.03	177,40
80	7	27	50	15,4	M.06.02.22.04	202,00
100	8	32	50	15,4	M.06.02.22.05	246,00
125	9	40	63	15,4	M.06.02.22.06	323,90
50	4	22	40	15,4	M.06.02.22.11	154,80
63	5	22	40	15,4	M.06.02.22.12	177,40
80	6	27	50	15,4	M.06.02.22.13	202,00
100	7	32	50	15,4	M.06.02.22.14	246,00
125	8	40	63	15,4	M.06.02.22.15	323,90

Plaquettes compatibles
AP..16

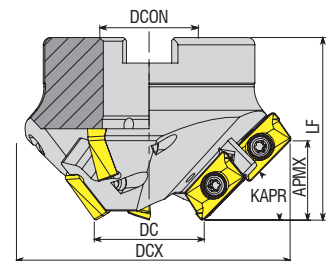

Référence	ZEP Totale Effective	KAPR	DC	DCX	DCON	APMX	LF	Code	Prix promo € HT
AHM15-AP16-D35x93-A27-A0306H	6	3	15	35	93	27	8	098154	264,60
AHM30-AP16-D35x87-A27-A0306H	6	3	30	35	87	27	15	098155	264,60
AHM45-AP16-D35x77-A27-A0306H	6	3	45	35	77	27	21,5	098156	264,60
AHM60-AP16-D35x65-A22-A0306H	6	3	60	35	65	22	26,5	098157	264,60
AHM75-AP16-D35x50-A22-A0306H	6	3	75	35	50	22	29,5	098158	264,60

PORTE-OUTILS AKKO

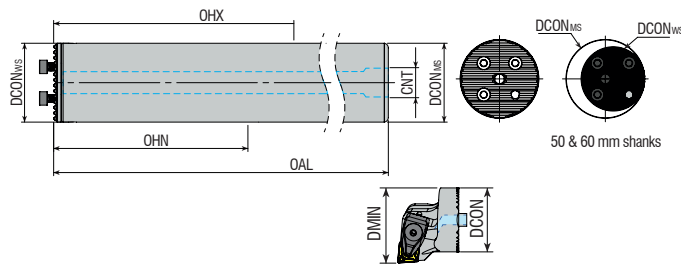

Informations techniques

Référence	DCONMS	DCONWS	OAL	OHN	OHX	CNT	DCON	DMIN	Code	Prix promo € HT
ATTB-D25-255-7D-H	25	25	255	88	158	G1/4	25	32	098084	887,60
ATTB-D32-320-7D-H	32	32	320	100	192	G3/8	32	40	098085	1017,80
ATTB-D40-408-7D-H	40	40	408	128	248	G1/2	40	50	098086	1148,00
ATTB-D50-519-7D-H	50	40	519	168	318	G1/2	40	63	098087	1415,40
ATTB-D60-628-7D-H	60	40	628	208	388	G3/4	40	80	098088	1677,20

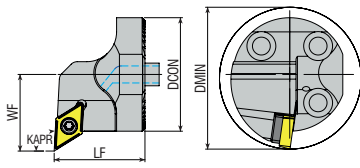

Référence	DCON	LF	WF	DMIN	Code R	Code L	Prix promo € HT
ATTC-A25 SDUCR/L 11	25	23	17	32	098089	098090	136,50
ATTC-A32 SDUCR/L 11	32	32	22	40	098091	098092	163,10
ATTC-A40 SDUCR/L 11	40	32	27	50	098093	098094	163,10

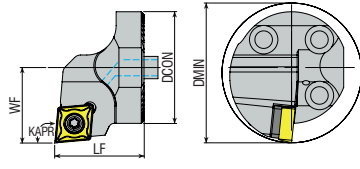

Référence	DCON	LF	WF	DMIN	Code R	Code L	Prix promo € HT
ATTC-A25 SCLCR/L 09	25	23	17	32	098095	098096	136,50
ATTC-A32 SCLCR/L 09	32	32	22	40	098097	098098	163,10
ATTC-A40 SCLCR/L 12	40	32	27	50	098099	098100	163,10

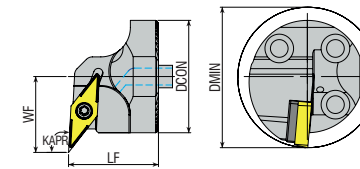

Référence	DCON	LF	WF	DMIN	Code R	Code L	Prix promo € HT
ATTC-A25 SVUCR/L 11	25	23	17	32	098101	098102	136,50
ATTC-A32 SVUCR/L 16	32	32	22	40	098103	098104	163,10
ATTC-A40 SVUCR/L 16	40	32	27	50	098105	098106	163,10

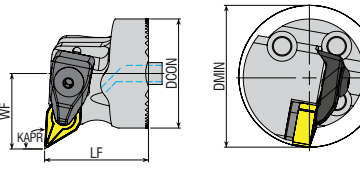

Référence	DCON	LF	WF	DMIN	Code R	Code L	Prix promo € HT
ATTC-A32 TDUNR/L 11	32	32	22	40	098107	098108	163,10
ATTC-A40 TDUNR/L 15	40	38	27	50	098109	098110	163,10

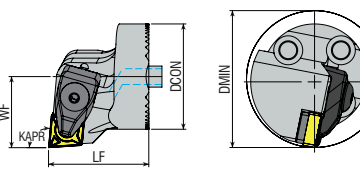

Référence	DCON	LF	WF	DMIN	Code R	Code L	Prix promo € HT
ATTC-A32 TCLNR/L 12	32	32	22	40	098111	098112	163,10
ATTC-A40 TCLNR/L 12	40	38	27	50	098113	098114	163,10

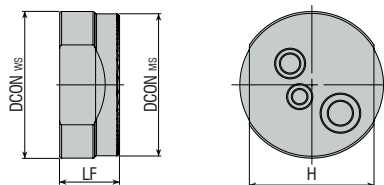

Référence	DCONWS	DCONMS	LF	H	Code	Prix promo € HT
ATTC-16-25	28	25	15	22	098115	37,80
ATTC-32-60	53	40	20	35	098116	49,70

PORTE-OUTILS AKKO

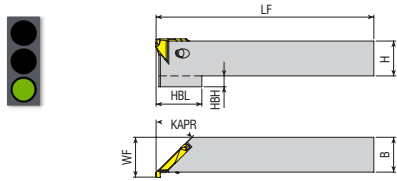

Référence	H	B	WF	LF	HLB	HBH	KAPR	Code R	Code L	Prix promo € HT
AAUT-T20-R/L-1616-45	16	16	18,3	125	21	5	45°	098162	098163	65,10
AAUT-T20-R/L-2020-45	20	20	22,3	125	21	5	45°	098164	098165	65,80
AAUT-T20-R/L-2525-45	25	25	27,3	150	-	-	45°	098166	098167	67,20

Référence	CW	S	RE	CDX	DMIN	Cdtnmt.	Code R	Code L	Prix promo € HT
T20.00.0815.45.04R/L	1,5	3,25	0,4	1,6	8	10	098168	098169	33,60
T20.00.1220.45.05R/L	2,0	3,25	0,5	1,8	12	10	098170	098171	33,60
T20.00.2024.45.06R/L	2,4	3,25	0,6	2,0	20	10	098172	098173	33,60
T20.00.1220.45.10R/L	2,0	3,25	1,0	1,8	12	10	098174	098175	43,20

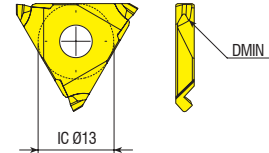

**Déconditionnement
Majoration 15 %**

PLAQUETTES | PLAQUETTES CBN MULTINSERT (CONDITIONNEMENT PAR 1)

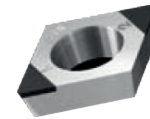

Nb insert	Désignation	Code	Prix tarif € HT
2	CCGW 060204 MHN20C	079008	26,00
2	CCGW 060204 MHN30C	079034	26,00
2	CCGW 060208 MHN20C	079011	26,00
2	CCGW 060208 MHN30C	079035	26,00
2	CCGW 09T304 MHN20C	079013	26,00
2	CCGW 09T304 MHN30C	079036	26,00
2	CCGW 09T308 MHN20C	079009	26,00
2	CCGW 09T308 MHN30C	079037	26,00
2	CNGA 120404 MHN20C	079054	26,00
2	CNGA 120404 MHN30C	079055	52,00
2	CNGA 120408 MHN10C	079004	25,00
4	CNGA 120408 MHN20C	079005	52,00
4	CNGA 120408 MHN30C	079056	52,00
2	DCGW 070204 MHN20C	079038	26,00
2	DCGW 070204 MHN30C	079045	26,00
2	DCGW 070208 MHN20C	079039	26,00
2	DCGW 070208 MHN30C	079046	26,00
2	DCGW 11T304 MHN20C	079043	26,00
2	DCGW 11T304 MHN30C	079047	26,00

Nb insert	Désignation	Code	Prix tarif € HT
2	DCGW 11T308 MHN20C	079044	26,00
2	DCGW 11T308 MHN30C	079048	26,00
2	DNGA 150604 MHN20C	079015	26,00
2	DNGA 150604 MHN30C	079057	26,00
2	DNGA 150608 MHN20C	079017	26,00
2	DNGA 150608 MHN30C	079058	26,00
3	TNGA 160404 MHN20C	079023	40,00
3	TNGA 160408 MHN20C	079019	40,00
3	TNGA 160408 MHN30C	079077	40,00
3	WNGA 080404 MHN20C	079024	40,00
3	WNGA 080404 MHN30C	079078	40,00
3	WNGA 080408 MHN20C	079025	40,00
3	WNGA 080408 MHN30C	079079	40,00

**MHN10C : SANS CHOC
MHN20C : OPÉRATION MIXTE
MHN30C : CHOC**

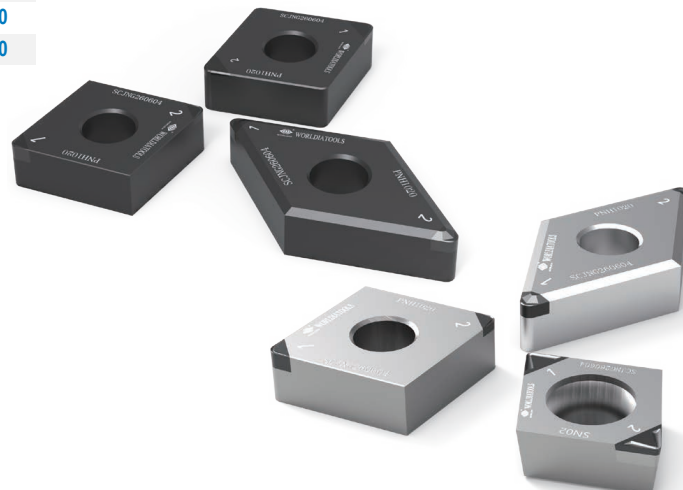

PLAQUETTES | KORLOY - PLAQUETTES ALUMINIUM (CONDITIONNEMENT PAR 10)

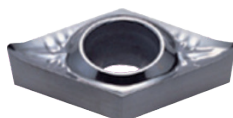

ALUMINIUM TOURNAGE POSITIVE

Désignation	Code	€ net HT
CCGT 060202 AK H01	079016	8,06
CCGT 060204 AK H01	079010	8,06
CCGT 09T302 AK H01	079018	9,53
CCGT 09T304 AK H01	079012	9,53
CCGT 09T308 AK H01	079020	9,53
CCGT 120404 AK H01	079014	10,65
DCGT 070202 AK H01	079111	8,06
DCGT 070204 AK H01	079030	8,06
DCGT 11T302 AK H01	079112	9,53
DCGT 11T304 AK H01	079032	9,53
TCGT 110202 AK H01	079752	8,30
TCGT 110204 AK H01	079250	8,30
TCGT 16T304 AK H01	079251	10,46
VCGT 110304 AK H01	079110	10,03
VCGT 160404 AK H01	079120	11,40

ALUMINIUM TOURNAGE NÉGATIVE

Désignation	Code	€ net HT
CNMG 120404 HA H01	079113	5,66
CNMG 120408 HA H01	079230	5,66
WNMG 060404 HA H01	079115	4,73
WNMG 060408 HA H01	079116	4,73
WNMG 080404 HA H01	079810	5,66
WNMG 080408 HA H01	079114	5,66

ALUMINIUM FRAISAGE

Désignation	Code	€ net HT
APKT 1604 PDR P K10M	079001	10,57

Pas de déconditionnement

PLAQUETTES | KORLOY - PLAQUETTES ISO TOURNAGE (CONDITIONNEMENT PAR 10)

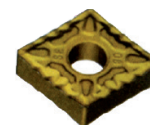

Désignation	Code	€ net HT	PLAQUETTES TOURNAGE	Code	Prix tarif € HT	
CNMG120408-MP NC3225	P15-P25 ACIER	0800014	5,52	CCGT 060204 AK PC8110	080563	7,85
DNMG150608-MP NC3225	P15-P25 ACIER	0800015	7,83	CCGT 09T304 AK PC8110	080561	9,26
WNMG060408-MP NC3225	P15-P25 ACIER	0800016	4,63	CCMT 060204 HMP PC8110	080472	4,56
WNMG080408-MP NC3225	P15-P25 ACIER	0800017	5,52	CCMT 09T304 HMP PC8110	080492	5,36
CNMG120408-MM NC9125	M20-M30 INOX	0800018	5,52			
DNMG150608-MM NC9125	M20-M30 INOX	0800019	7,83			
WNMG060408-MM NC9125	M20-M30 INOX	0800020	4,63			
WNMG080408-MM NC9125	M20-M30 INOX	0800021	5,52			

Pas de déconditionnement

PLAQUETTES | PLAQUETTES DE FRAISAGE (CONDITIONNEMENT PAR 10)

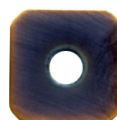

PLAQUETTES FRAISAGE	Code	Prix tarif € HT
APKT 1003PDR.I52 T528N	088402	5,15
APMT 1604 PDR.I52 T528N	088401	5,15

Pas de déconditionnement

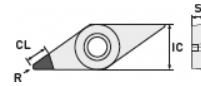
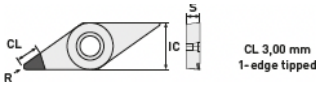

Désignation	IC	S	R	Code	€ net HT	Désignation	IC	S	R	Code	€ net HT
PL VCGT 110302 FN CVD	6,35	3,2	0,20	079817	60,00	PL VBGT 110202 FN CVD	6,35	2,2	0,20	079831	60,00
PL VCGT 110304 FN CVD	6,35	3,2	0,40	079818	60,00	PL VBGT 110204 FN CVD	6,35	2,2	0,40	079832	60,00
PL VCGT 110308 FN CVD	6,35	3,2	0,80	079819	60,00	PL VBGT 110208 FN CVD	6,35	2,2	0,80	079833	60,00
PL VCGT 160402 FN CVD	9,525	4,8	0,20	079820	60,00	PL VBGT 160402 FN CVD	9,525	4,8	0,20	079834	60,00
PL VCGT 160404 FN CVD	9,525	4,8	0,40	079821	60,00	PL VBGT 160404 FN CVD	9,525	4,8	0,40	079835	60,00
PL VCGT 160408 FN CVD	9,525	4,8	0,80	079822	60,00	PL VBGT 160408 FN CVD	9,525	4,8	0,80	079836	60,00
PL VCGT 160412 FN CVD	9,525	4,8	1,20	079823	60,00	PL VBGT 160412 FN CVD	9,525	4,8	1,20	079837	60,00
PL VCGT 110302 FN PCD	6,35	3,2	0,20	079824	20,00	PL VBGT 110202 FN PCD	6,35	2,2	0,20	079838	20,00
PL VCGT 110304 FN PCD	6,35	3,2	0,40	079825	20,00	PL VBGT 110204 FN PCD	6,35	2,2	0,40	079839	20,00
PL VCGT 110308 FN PCD	6,35	3,2	0,80	079826	20,00	PL VBGT 110208 FN PCD	6,35	2,2	0,80	079840	20,00
PL VCGT 160402 FN PCD	9,525	4,8	0,20	079827	20,00	PL VBGT 160402 FN PCD	9,525	4,8	0,20	079841	20,00
PL VCGT 160404 FN PCD	9,525	4,8	0,40	079828	20,00	PL VBGT 160404 FN PCD	9,525	4,8	0,40	079842	20,00
PL VCGT 160408 FN PCD	9,525	4,8	0,80	079829	20,00	PL VBGT 160408 FN PCD	9,525	4,8	0,80	079843	20,00
PL VCGT 160412 FN PCD	9,525	4,8	1,20	079830	20,00	PL VBGT 160412 FN PCD	9,525	4,8	1,20	079844	20,00

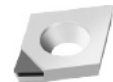
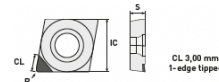
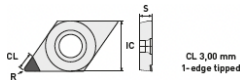

Désignation	IC	S	R	Code	€ net HT	Désignation	IC	S	R	Code	€ net HT
PL DCGT 070202 FN CVD	6,35	2,4	0,20	079845	56,00	PL CCGT 060202 FN CVD	6,35	2,4	0,20	079859	56,00
PL DCGT 070204 FN CVD	6,35	2,4	0,40	079846	56,00	PL CCGT 060204 FN CVD	6,35	2,4	0,20	079860	56,00
PL DCGT 070208 FN CVD	6,35	2,4	0,80	079847	56,00	PL CCGT 060208 FN CVD	6,35	2,4	0,20	079861	56,00
PL DCGT 11T302 FN CVD	9,525	4	0,20	079848	56,00	PL CCGT 09T302 FN CVD	9,525	4	0,20	079862	56,00
PL DCGT 11T304 FN CVD	9,525	4	0,40	079849	56,00	PL CCGT 09T304 FN CVD	9,525	4	0,20	079863	56,00
PL DCGT 11T308 FN CVD	9,525	4	0,80	079850	56,00	PL CCGT 09T308 FN CVD	9,525	4	0,20	079864	56,00
PL DCGT 11T312 FN CVD	9,525	4	1,20	079851	56,00	PL CCGT 09T312 FN CVD	9,525	4	0,20	079865	56,00
PL DCGT 070202 FN PCD	6,35	2,4	0,20	079852	20,00	PL CCGT 120402 FN CVD	12,70	4,8	0,20	079866	56,00
PL DCGT 070204 FN PCD	6,35	2,4	0,40	079853	20,00	PL CCGT 120404 FN CVD	12,70	4,8	0,20	079867	56,00
PL DCGT 070208 FN PCD	6,35	2,4	0,80	079854	20,00	PL CCGT 120408 FN CVD	12,70	4,8	0,20	079868	56,00
PL DCGT 11T302 FN PCD	9,525	4	0,20	079855	20,00	PL CCGT 060202 FN PCD	6,35	2,4	0,20	079869	20,00
PL DCGT 11T304 FN PCD	9,525	4	0,40	079856	20,00	PL CCGT 060204 FN PCD	6,35	2,4	0,20	079870	20,00
PL DCGT 11T308 FN PCD	9,525	4	0,80	079857	20,00	PL CCGT 060208 FN PCD	6,35	2,4	0,20	079871	20,00
PL DCGT 11T312 FN PCD	9,525	4	1,20	079858	20,00	PL CCGT 09T302 FN PCD	9,525	4	0,20	079872	20,00
						PL CCGT 09T304 FN PCD	9,525	4	0,20	079873	20,00
						PL CCGT 09T308 FN PCD	9,525	4	0,20	079874	20,00
						PL CCGT 09T312 FN PCD	9,525	4	0,20	079875	20,00
						PL CCGT 120402 FN PCD	12,70	4,8	0,20	079876	20,00
						PL CCGT 120404 FN PCD	12,70	4,8	0,20	079877	20,00
						PL CCGT 120408 FN PCD	12,70	4,8	0,20	079878	20,00

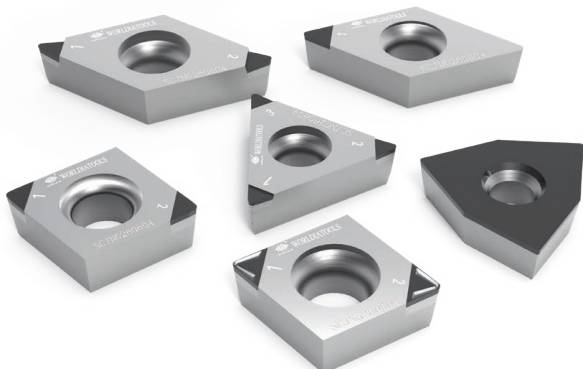

CVD-D

Idéal pour l'usinage de :
 PMMA / ALUMINIUM < 10% Si | Carbure | Céramique | Composites
 GFRP-CFRP | Cuivre, alliages cuivre | Bronze, céramique bronze |
 Magnésium | Plastique | Argent, or, platine | Titane | Zirconium

PCD

Idéal pour l'usinage de :
 ALUMINIUM < 10% Si | Bronze | Cuivre, alliages de cuivre | Graphite |
 Magnésium | PEEK | Alliages tungsten

PLAQUETTES | FILETAGE INOX ET PORTE-OUTILS

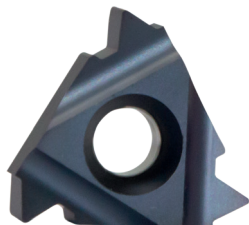

Désignation	Code	Désignation	Code	Désignation	Code
2ER1.5ISOXTIALN	076632	3ER1.0ISOXTIALN	076640	3IR0.8ISOXTIALN	076650
2IR0.8ISOXTIALN	076633	3ER1.25ISOXTIALN	076660	3IR1.0ISOXTIALN	076651
2IR1.0ISOXTIALN	076634	3ER1.5ISOXTIALN	076641	3IR1.5ISOXTIALN	076652
2IR1.5ISOXTIALN	076635	3ER1.75ISOXTIALN	076661	3IR2.0ISOXTIALN	076653
2IR2.0ISOXTIALN	076667	3ER2.0ISOXTIALN	076642	3IR2.5ISOXTIALN	076654
3ER0.35ISOXTIALN	076657	3ER2.5ISOXTIALN	076643	3IR3.0ISOXTIALN	076655
3ER0.45ISOXTIALN	076658	3ER3.0ISOXTIALN	076644	3IR3.5ISOXTIALN	076656
3ER0.5ISOXTIALN	076636	3ER3.5ISOXTIALN	076645	3IR0.35ISOXTIALN	076662
3ER0.6ISOXTIALN	076637	3IR0.4ISOXTIALN	076646	3IR0.45ISOXTIALN	076663
3ER0.7ISOXTIALN	076638	3IR0.5ISOXTIALN	076647	3IR0.75ISOXTIALN	076664
3ER0.75ISOXTIALN	076659	3IR0.6ISOXTIALN	076648	3IR1.25ISOXTIALN	076665
3ER0.8ISOXTIALN	076639	3IR0.7ISOXTIALN	076649	3IR1.75ISOXTIALN	076666



CONDITIONNEMENT PAR 10
Prix au détail : 12,50 € HT



Désignation	Code	Prix promo € net HT
PO FIL. EXTER. SER 2020 K16	076450	55,40
PO FIL. EXTER. SER 2525 M16	076451	65,41
PO FIL. INTER. SIR 0013 M16	076452	54,17
PO FIL. INTER. SIR 0016 P16	076453	54,17
PO FIL. INTER. SIR 0025 R16	076454	80,70
PO FIL. INTER. SIR 0032 S16	076455	86,19
PO FILETER INTER. SIR 0020 P16	076901	64,27

PLAQUETTES | FILETAGE UNIVERSEL



Désignation	Code	Désignation	Code	Désignation	Code	Désignation	Code
16ER 0.50 ISO FC TIALN	076400	16ER 9W FC TIALN	076109	16IR 28W FC TIALN	076130	16IR 12UN FC TIALN	076099
16ER 0.70 ISO FC TIALN	076402	16ER 11W FC TIALN	076111	16ER 8UN FC TIALN	076080	16IR 14UN FFC TIALN	076100
16ER 0.75 ISO FC TIALN	076401	16ER 14W FC TIALN	076112	16ER 9UN FC TIALN	076081	16IR 16UN FC TIALN	076101
16ER 0.80 ISO FC TIALN	076403	16ER 16W FC TIALN	076113	16ER 10UN FC TIALN	076082	16IR 18UN FC TIALN	076102
16ER 1.00 ISO FC TIALN	076404	16ER 18W FC TIALN	076114	16ER 11,5 UN FC TIALN	076084	16IR 20UN FC TIALN	076103
16ER 1.25 ISO FC TIALN	076405	16ER 19W FC TIALN	076115	16ER 11UN FC TIALN	076083	16IR 24UN FC TIALN	076104
16ER 1.50 ISO FC TIALN	076406	16ER 20W FC TIALN	076116	16ER 12UN FC TIALN	076085	16IR 27UN FC TIALN	076105
16ER 1.75 ISO FC TIALN	076407	16ER 24W FC TIALN	076117	16ER 13UN FC TIALN	076086	16IR 28UN FC TIALN	076106
16ER 2.0 ISO FC TIALN	076409	16ER 28W FC TIALN	076118	16ER 14UN FC TIALN	076087	16ER A55 FC TIALN	076412
16ER 2.5 ISO FC TIALN	076410	16IR 7W FC TIALN	076119	16ER 16UN FC TIALN	076088	16ER A60 FC TIALN	076413
16ER 3.0 ISO FC TIALN	076411	16IR 8W FC TIALN	076120	16ER 18UN FC TIALN	076089	16ER AG55 FC TIALN	076414
16IR 1.0 ISO FC TIALN	076418	16IR 9W FC TIALN	076121	16ER 20UN FC TIALN	076090	16ER AG60 FC TIALN	076415
16IR 1.25 ISO FC TIALN	076419	16IR 10W FC TIALN	076122	16ER 24UN FC TIALN	076091	16ER G55 FC TIALN	076416
16IR 1.5 ISO FC TIALN	076420	16IR 11W FC TIALN	076123	16ER 27UN FC TIALN	076092	16ER G60 FC TIALN	076417
16IR 1.75 ISO FC TIALN	076430	16IR 14W FC TIALN	076124	16ER 28UN FC TIALN	076093	16IR A55 FC TIALN	076424
16IR 2.0 ISO FC TIALN	076421	16IR 16W FC TIALN	076125	16IR 8UN FC TIALN	076094	16IR A60 FC TIALN	076425
16IR 2.5 ISO FC TIALN	076422	16IR 18W FC TIALN	076126	16IR 9UN FC TIALN	076095	16IR AG55 FC TIALN	076426
16IR 3.0 ISO FC TIALN	076423	16IR 19W FC TIALN	076127	16IR 10UN FC TIALN	076096	16IR AG60 FC TIALN	076427
16ER 7W FC TIALN	076107	16IR 20W FC TIALN	076128	16IR 11,5UN FC TIALN	076098	16IR G55 FC TIALN	076428
16ER 8W FC TIALN	076108	16IR 24W FC TIALN	076129	16IR 11UN FC TIALN	076097	16IR G60 FC TIALN	076429

CONDITIONNEMENT PAR 10
Prix au détail :
- ISO et W = 11,50 € HT
- UN = 12,50 € HT



PORTE OUTILS | TINY TOOL KITS



Type	Code	Prix € net HT
TT-KIT4-20	076012	149,00
TT-KIT5-20	076013	159,00



*jusqu'à épuisement des stocks

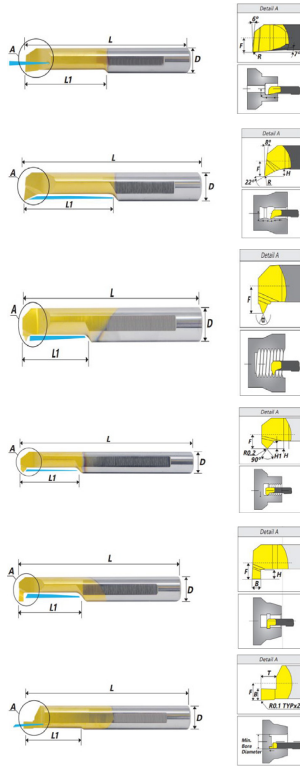

Intérieur	D	L	L1	R	F	REF	Dia. Mini
TTTR4-0,2R-10L	4	51	10	0,2	1,7	TTH20-4	4,1
TTTR5-0,2R-10L	5	51	10	0,2	2,1	TTH20-5	5,1

Profil	D	L	L1	R	F	H	REF	Dia. Mini
TTPR4-0,2R-10L	4	51	10	0,2	1,7	0,8	TTH20-4	4,1
TTPR5-0,2R-15L	5	51	15	0,2	2,1	1,2	TTH20-5	5,1

Filetage	mm	TPI	L	L1	D	F	Angle	REF	Dia. Mini
TTIR4-A60-15L	0,8/1,0	32-24	51	15	4	1,8	60	TTH20-4	4,1
TTIR5-A60-15L	1,0/1,25	24-20	51	15	5	2,3	60	TTH20-5	5,1

Chanfreinage	L	L1	D	F	H	H1	R	REF	Dia. Mini
TTCR4-0,2R-15L	51	15	4	1,7	0,8	0,4	0,2	TTH20-4	4,1
TTCR5-0,2R-15L	51	15	5	2,1	1,2	0,7	0,2	TTH20-5	5,1

Rainurage	L	L1	D	B	H	F	REF	Dia. Mini
TTGR4-1,0-15L	51	15	4	1	1	1,7	TTH20-4	4,1
TTGR5-1,0-22L	51	22	5	1	1,2	2,3	TTH20-5	5,1

Rainurage axial	L	L1	D	F	B	T	REF	Dia. Mini
TTFR4-1,0B-15L	51	15	4	1,95	1	1,5	TTH20-4	4,1
TTFR5-1,0B-22L	51	22	5	2,45	1	1,5	TTH20-5	5,1

CHASSE CONES ET NETTOYEURS

CHASSE CONE



Taille	L	Référence	Code	Promo € net ht
MK0	90	01-2000	428001	3,50
MK1+2	140	01-2002	428002	3,00
MK3	190	01-2003	428004	4,10
MK4	225	01-2004	428005	5,20
MK5+6	265	01-2005	428006	8,40

SK

Taille	Référence	Code	Promo € net ht
SK30	09-76200030	431003B	11,10
SK40	09-76200040	431004B	11,10
SK50	09-76200050	431005B	16,30



MT

Taille	Référence	Code	Promo € net ht
MK1	09-76200001	431006B	7,80
MK2	09-76200002	431007B	6,80
MK3	09-76200003	431008B	8,30
MK4	09-76200004	431009B	11,00
MK5	09-76200005	431010B	15,40
MK6	09-76200006	431011B	34,60



CHASSE CONE SEMI AUTOMATIQUE



Taille	L	Référence	Code	Promo € net ht
MK1+2+3	317	01-8003	428011	39,70
MK4+5+6	380	01-8006	428012	49,60

HSK

Taille	Référence	Code	Promo € net ht
HSK32	09-76205032	431012B	45,20
HSK40	09-76205040	431013B	40,70
HSK50	09-76205050	431014B	42,70
HSK63	09-76205063	431015B	42,70
HSK80	09-76205080	431016B	55,40
HSK100	09-762050100	431017B	59,10



ER

Taille	Référence	Code	Promo € net ht
ER16	09-76202016	431018B	15,80
ER20	09-76202020	431019B	19,30
ER25	09-76202025	431020B	22,70
ER32	09-76202032	431021B	26,90
ER40	09-76202040	431022B	31,00



SOMECO



Points forts

- ✓ Extrêmement compact
- ✓ Palpeurs interchangeables, offrant une solution pour chaque application
- ✓ Palpeur orientable à 90° pour mesure de surfaces convexes ou concaves
- ✓ Cale d'ajustement en hauteur intégrée
- ✓ Peut-être utilisé sur une base magnétique ou support à colonne
- ✓ Montage de la rallonge de palpeur 100 mm pour la mesure dans les alésages profonds.
- ✓ Retardateur de 1 à 10 sec. pour une mesure plus stable
- ✓ High-tech, peut-être utiliser avec les APPLIS "ROUGHNESS STUDIO", sur Smartphone, tablette ou PC

Désignation	Référence	Code	€ promo ht
Rugosimètre portable LiteSURF & palpeur SB51	422300215LAT	522005	2 170,00
Application pour rugosimètre Roughness Studio 1.424	422309265	522006	555,00
Rallonge 50 mm de palpeur pour rugosimètre LiteSURF	422312305	522007	230,00
Rallonge 100 mm de palpeur pour rugosimètre LiteSURF	422312310	522008	250,00



Caractéristiques :

- ✓ Lecture : 0.005 mm
- ✓ Tambour et fourreau gradués, chromé mat
- ✓ Avec bagues d'étalonnage et rallonge

- ✓ Touches en carbure de tungstène
- ✓ Contrôle à fond d'alésage à partir Ø 12 mm jusqu'au Ø 100 mm
- ✓ Livré en coffret bois

Ref.	Nb de micromètres	Précision du vernier	Profondeur de mesure	Longueur de la rallonge	Ø bagues	Référence	Code	€ promo ht
3,5 - 6,5	4	56	20	sans	4 - 5,5	392100000	522044	690,00
6 - 12	3	40	50	100	8 - 10	392100100	522045	440,00
12 - 20	2	56	60	150	16	392100200	522046	385,00
20 - 40	4	56	80	150	25 - 35	392100300	522047	690,00
40 - 100	6	75	90	150	50 - 70 - 90	392100400	522048	1 110,00



Caractéristiques :

- ✓ Lecture : 0.005 mm
- ✓ Tambour et fourreau gradués, chromé mat
- ✓ Touches en carbure de tungstène
- ✓ Contrôle à fond d'alésage à partir Ø 12 mm jusqu'au Ø 100 mm
- ✓ Livré en coffret bois sans bague étalon / sans rallonge

Capacité	Référence	Code	€ promo ht	Capacité	Référence	Code	€ promo ht	Capacité	Référence	Code	€ promo ht
3 - 4	392101000	522051	190,00	20 - 25	392101900	522060	190,00	90 - 100	392102800	522069	285,00
4 - 4,5	392101100	522052	190,00	25 - 30	392102000	522061	190,00	100 - 125	392102900	522070	380,00
4,5 - 5,5	392101200	522053	190,00	30 - 35	392102100	522062	190,00	125 - 150	392103000	522071	380,00
5,5 - 6,5	392101300	522054	190,00	35 - 40	392102200	522063	190,00	150 - 175	392103100	522072	380,00
6 - 8	392101400	522055	190,00	40 - 50	392102300	522064	285,00	175 - 200	392103200	522073	380,00
8 - 10	392101500	522056	190,00	50 - 60	392102400	522065	285,00	200 - 225	392103300	522074	505,00
10 - 12	392101600	522057	190,00	60 - 70	392102500	522066	285,00	225 - 250	392103400	522075	505,00
12 - 16	392101700	522058	190,00	70 - 80	392102600	522067	285,00	250 - 275	392103500	522076	505,00
16 - 20	392101800	522059	190,00	80 - 90	392102700	522068	285,00	275 - 300	392103600	522077	505,00

AFFUTEUSE DE FORETS



FTX-13-AB
499000*
560,63 €

Le saviez-vous ?

Nous vendons aussi
les meules
Code : 499002 / 499003

CBN14
192,16 € HT

SD14
221,63 € HT



DATOS TÉCNICOS / TECHNICAL SPECIF. / CARACT. TECHNIQUES

Alimentación / Voltage / Alimentation		220V - F1
Potencia / Power / Puissance	W	180
Velocidad / Speed / Vitesse	rpm	4800
Capacidad afilado / Grinding range / Gamme de meulage	mm	ø3 - ø13
Ángulo del afilado / Point angle		100° (95°) - 135°
Peso / Weight / Poids	kg.	10
Dimensiones / Dimensions / Dimensions	mm.	320x180x190
Código EAN / EAN code		8423640153141



| LIVRÉE AVEC MEULE POUR FORÊTS HSS - MEULE DIAMANT POUR FORÊT CARBURE EN OPTION |

COLONNE DE MESURE | 1D PALPAGE MOTORISÉ OPTIMA-M



Désignation	Référence	Code
COLONNE OPTIMA M450	33 13 10250	510000
COLONNE OPTIMA M700	33 13 10260	510001

Livrée avec :

- 1 Étalon de calibration
- 1 Support de palpeur
- 1 Palpeur touche carbure Ø6
- 1 Poignée
- Chargeur, housse et manuel d'utilisation
- Logiciel (en anglais) + câble USB pour exports des résultats vers un PC

A PARTIR DE
3 985€ HT*

Caractéristiques Techniques :

Modèles	Optima-M 450	Optima-M 700
Code	33 13 10250	33 13 10260
Course de mesure	450 mm	700 mm
Plage de mesure avec inversion du palpeur	765/830 mm	1015/1080 mm
Résolution paramétrable	0,010 - 0,005 - 0,001 - 0,0005 mm	
Répétabilité	Surface plane ≤ 0,0015 mm Surface cylindrique ≤ 0,0030 mm	
Vitesse maxi de déplacement	Jusqu'à 600 mm/sec	
Force de mesure	1,2 N ± 0,2	
Incertitude de mesure*	2,5 + L / 250 µm (L=longueur en mm)	
Perpendicularité**	6,5 µm	10 µm
Déplacement colonne	Sur coussin d'air (compresseur intégré)	
Autonomie sur accu Li ION	20 Heures	
Température d'utilisation	10°C à 40°C	
Poids	23 kg	27 kg
Palpeur standard	Bille carbure Ø 6 x 48 mm	



Points forts



✓ Palpage motorisé assurant une bonne répétabilité



✓ Utilisation simple & intuitive, touche à effleurement



✓ 5 derniers résultats visibles à l'écran sous forme d'icône



✓ Traçabilité : Export des résultats vers PC via logiciel inclus

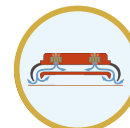

✓ Déplacement sur coussin d'air pour faciliter le mouvement sur le marbre



THERMOGRIP | ISG 1200



ISG 1200
5 725 €
HT *

Référence	Article	Prix € net HT
ISG1200TLK-8-BIL-D	5190238	5 725,00
T3-W/HSK100	6725938	179,00
T3-W/HSK32	6725939	154,00
T3-W/HSK40	6725940	154,00
T3-W/HSK50	6725941	154,00
T3-W/HSK63	6725942	154,00
T3-W/HSK80	6725943	154,00
T3-W/SK40	6725944	154,00
T3-W/SK50	6725945	154,00
T3-K/12,1-16	6725951	140,00
T3-K/16,1-22	6725953	140,00
T3-K/22,1-32	6725954	140,00
T3-K/6-9	6725955	140,00
T3-K/9,1-12	6725956	140,00
T3-W/SK30	6725958	154,00

- Saisie aisée des paramètres de frettage en scannant les codes-barres.
- La technique d'induction à économie d'énergie garantit une longue durée de vie des outils
- Centrage précis de l'outil
- Faible encombrement et utilisation mobile
- Force de maintien maximale et résistance durable, même dans un environnement huileux
- Plage de serrage diamètre 3 à 32 mm pour tous les mandrins de frettage T, TSF, TB et TER (HSS diamètre 10 - 20 mm / HM diamètre 3 - 32 mm)
- Refroidissement par air pulsé (support de cônes disponible en option)
- Longueur maximale de l'outil à partir du référentiel du cône : 450 mm HSK-A63
- Longueur de refroidissement : 200 mm

FRETTAGE D'OUTILS CARBURE - DIAMÈTRE DE QUEUE D'OUTIL 3 | 4H4 | 5H5 | 6 À 20 TOLÉRANCE H6
FRETTAGE D'OUTILS ACIER RAPIDE - DIAMÈTRE DE QUEUE D'OUTIL 6 À 20 MM TOLÉRANCE H6

THERMOGRIP | ISG 2430TLK FS

*jusqu'à épuisement des stocks



ISG 2430TLK-8FS
780020
6 350€

- Affichage graphique
- Frettage par induction, une station de travail et de refroidissement par ventilation
- Un collier d'induction avec trois disques interchangeables
- Longueur de frettage maximum : 450mm (pour un HSKA63)
- Longueur de refroidissement maximum : 200mm (pour un HSKA63)
- Support de cône jusqu'à HSKA100 ou SA50

ALIMENTATION ÉLECTRIQUE : 3x400 V / 16A (TROIS PHASES + TERRE + NEUTRE)
POIDS APPROXIMATIF : 25 KGS
DIMENSIONS : L 780MM x P 535 MM x H 970 MM

ACCESSOIRES POUR ISG 2430TLK 8 FS		Prix tarif € HT	ACCESSOIRES POUR ISG 2430TLK 8 FS		Prix tarif € HT
SUPPORT PORTE	OUTIL T3 W / HSK 25 40	271,00	SUPPORT PORTE	OUTIL T3 W / SK 40	127,00
SUPPORT PORTE	OUTIL T3 W / HSK 32	127,00	SUPPORT PORTE	OUTIL T3 W / SK 50	107,00
SUPPORT PORTE	OUTIL T3 W / HSK 40	127,00	REFROIDISSEUR T3	K/3 5,9	115,00
SUPPORT PORTE	OUTIL T3 W / HSK 50	127,00	REFROIDISSEUR T3	K/6 9	115,00
SUPPORT PORTE	OUTIL T3 W / HSK 63	127,00	REFROIDISSEUR T3	K/9,1 12	115,00
SUPPORT PORTE	OUTIL T3 W / HSK 80	127,00	REFROIDISSEUR T3	K/12,1 16	115,00
SUPPORT PORTE	OUTIL T3 W / HSK 100	148,00	REFROIDISSEUR T3	K/16,1 22	115,00
SUPPORT PORTE	OUTIL T3 W / SK 30	127,00	Compatibles ISG3430		

THERMOGRIP | ISG 3430TLK



ISG 3430TLK-11WS
5102054
9 055€

- Ecran graphique
- Frettage de 3-32mm pour des queues d'outil en carbure
- Frettage de 6-32mm pour des queues d'outils en acier
- Livré avec 4 disques de ferrite
- Bobine interchangeable
- Longueur d'outil max : 450mm (avec un attachement en HSKA63)
- Longueur de refroidissement : 200mm (avec un attachement en HSKA63)
- Refroidissement par air pulsé
- Support de cônes : jusqu'à HSKA100 / SA50
- Poids : 69kg
- Alimentation électrique : 400V /16A (3 phases avec Terre et neutre)





elbo controlli **NIKKEN**
rock solid measurement



• **SIMPLE ET RAPIDE**

Le nouveau logiciel qui gère le banc garantit des performances incroyables, en gardant toujours cette touche de simplicité qui distingue les bancs de pré-réglages Elbo Controlli NIKKEN.

• **INTERCHANGEABLE**

L'E236+ utilise le système de broches interchangeable (ISO/BT/HSK/système polygonal, etc.), ce qui évite l'utilisation d'adaptateurs qui peuvent introduire des erreurs.

• **UN NOUVEAU POSITIONNEMENT**

Le nouveau système de positionnement des axes vous aide à visualiser l'arrête de coupe de votre outil, à mesurer au center de l'écran rapidement et facilement.



| AUTRES MODÈLES, NOUS CONSULTER |

MANDRIN À PINCE 5C



Mandrin à pince 5C
Montage central



C mm	A (Ø) mm	D1 mm	F mm	G mm	B mm	RPM min-1	kg	Référence	Code
4	126	95	108	3 x M8 x 45	107,4	6000	4,5	ZE-SF5C-125	403018

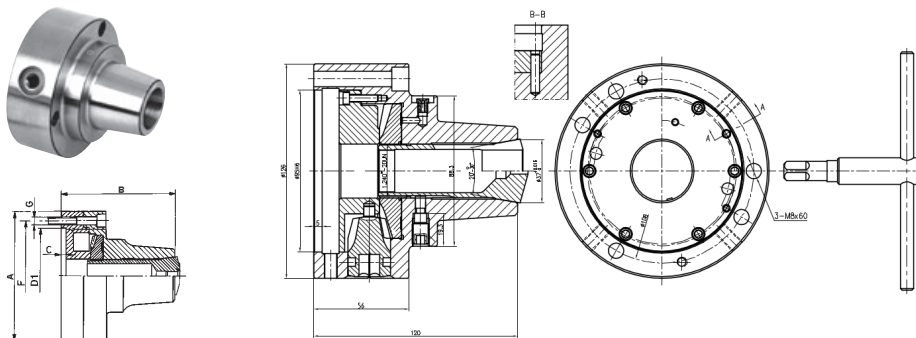

280,98 €
net HT



Pince type 385E (5C)
Pas de 0,5 mm

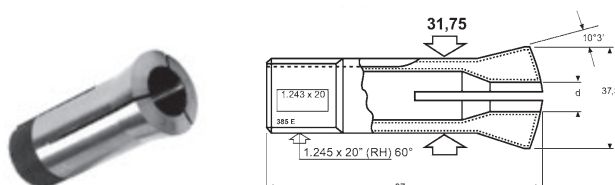

D mm	Référence	Code
3 - 30 mm	06-385E-Ø	420300-420323

14 €
net HT

ATTACHEMENT | PINCES ER DIN 6499 | CLASSE 1



PINCES ER16 CLASSE 1

Ø D	Code
3 2	427334B
4 3	427335B
5 4	427336B
6 5	427337B
7 6	427338B
8 7	427339B
9 8	427340B
10 9	427341B

8,40
€ HT

PINCES ER20 CLASSE 1

Ø D	Code	Ø D	Code	Ø D	Code
1 0,5	427350B	4 3	427355B	9 8	427360B
1,5 1	427351B	5 4	427356B	10 9	427361B
2 1	427352B	6 5	427357B	11 10	427362B
2,5 2	427353B	7 6	427358B	12 11	427363B
3 2	427354B	8 7	427359B	13 12	427364B

9,40
€ HT



PINCES ER25 CLASSE 1

Ø D	Code	Ø D	Code	Ø D	Code
1 0,5	427370B	7 6	427378B	15 14	427386B
1,5 1	427371B	8 7	427379B	16 15	427387B
2 1,5	427372B	9 8	427380B	17 16	427366B
2,5 2	427373B	10 9	427381B	18 17	427367B
3 2	427374B	11 10	427382B	19 18	427368B
4,5 3	427375B	12 11	427383B	20 19	427369B
5 4	427376B	13 12	427384B		
6 5	427377B	14 13	427385B		

8,40
€ HT

PINCES ER32 CLASSE 1

Ø D	Code	Ø D	Code	Ø D	Code
2 1,5	427248B	9 8	427256B	16 15	427263B
3 2	427250B	10 9	427257B	17 16	427264B
4 3	427251B	11 10	427258B	18 17	427265B
5 4	427252B	12 11	427259B	19 18	427266B
6 5	427253B	13 12	427260B	20 19	427267B
7 6	427254B	14 13	427261B		
8 7	427255B	15 14	427262B		

7,20
€ HT

ATTACHEMENT | PINCES ER DIN 6499 PRECISION 0,005



PINCES ER16 DE PRÉCISION 5 MICRONS

Ø D	Code	Ø D	Code	Ø D	Code
1,0 0,5	423240	4,5 3,5	423247	8,0 7,0	423254
1,5 1,0	423241	5,0 4,0	423248	8,5 7,5	423255
2,0 1,0	423242	5,5 4,5	423249	9 8,0	423256
2,5 2,00	423243	6,0 5,00	423250	9,5 8,5	423257
2,0 3,0	423244	6,5 5,5	423251	10,0 9,0	423258
2,5 3,5	423245	7,0 6,00	423252		
3,0 4,0	423246	7,5 6,5	423253		

PINCES ER20 DE PRÉCISION 5 MICRONS

Ø D	Code	Ø D	Code
1	423904	6	423909
2	423905	8	423910
3	423906	10	423911
4	423907	12	423912
5	423908		

PINCES ER25 DE PRÉCISION 5 MICRONS

Ø D	Code	Ø D	Code	Ø D	Code
1 0,5	423260	6,5 5,5	423271	12 11	423282
1,5 1	423261	7,0 6,0	423272	12,5 11,5	423283
2 1,5	423262	7,5 6,5	423273	13 12	423284
2,5 2	423263	8,0 7,0	423274	13,5 12,5	423285
3 2	423264	8,5 7,5	423275	14 13	423286
3,5 3	423265	9,0 8,0	423276	14,5 13,5	423287
40 3	423266	9,5 8,5	423277	15 14	423288
4,5 3,5	423267	10,0 9,0	423278	15,5 14,5	423289
5 4	423268	10,5 9,5	423279	16 15	423290
5,5 4,5	423269	11,0 10,0	423280		
6 5	423270	11,5 10,5	423281		

PINCES ER32 DE PRÉCISION 5 MICRONS

Code	Ø D	Code	Ø D	Code	Ø D
2 1,5	427248	9 8	427256	16 15	427263
3 2	427250	10 9	427257	17 16	427264
4 3	427251	11 10	427258	18 17	427265
5 4	427252	12 11	427259	19 18	427266
6 5	427253	13 12	427260	20 19	427267
7 6	427254	14 13	427261		
8 7	427255	15 14	427262		



12,50
€ HT

ATTACHEMENT | SERIE PINCES ER16 | ER32 | ER32UP



SERIE PINCES	Code	Prix promo € net HT
SERIE 13 PINCES ER11 Ø 1 7	870361	179,83
SERIE 8 PINCES ER16 DIN6499 CLASSE 1 Ø D 3 20	427996P	70,35
SERIE 18 PINCES ER32 DIN6499 CLASSE 1 Ø D 3 20	427999P	119,70
SERIE 11 PINCES ER EXS20 DIN6499 CLASSE 1 Ø D 3 13	427997B	105,00
SERIE 14 PINCES ER ESX25 DIN6499 CLASSE 1 Ø D 3 16	427998B	131,25



SERIE PINCES	Code	Prix promo € net HT
SERIE 10 PINCES ER16UP PRECISION 5 MICRONS	427904B	122,50
SERIE 12 PINCES ERX20UP PRECISION 5 MICRONS	427905B	162,75
SERIE 14 PINCES ER25UP PRECISION 5 MICRONS	427906P	172,41
SERIE 18 PINCES ER32UP DIN6499 5 micron Ø D 3 20	427903P	225,75

ATTACHEMENT | PINCES ARROSAGE FACE - ER 16 | 25 | 32 JET



PRÉCISION 0,008



PINCES ER16 JET

Ø D	Code
3	800156
4	800157
5	800158
6	800159
7	800160

PINCES ER25 JET

Ø D	Code	Ø D	Code
3	800161	9	800167
4	800162	10	800168
5	800163	11	800169
6	800164	12	800170
7	800165	13	800171
8	800166	14	800172

PINCES ER32 JET

Ø D	Code	Ø D	Code
6	800030	14	800037
7	800031	15	800038
8	800032	16	800039
9	800033	17	800040
10	800034	18	800041
11	800035	19	800042
12	800036	20	800043

ATTACHEMENT | PINCES ARROSAGE FACE - ER 16 | 25 | 32 SUPER JET



PINCE AVEC
CANALUX
D'ARROSAGE



PINCES ER16 JET

Ø D	Code
2	800177
3	800178
4	800179
5	800180
6	800181
7	800182
8	800183
9	800184
10	800185

PINCES ER25 JET

Ø D	Code	Ø D	Code
3	800186	10	800193
4	800187	11	800194
5	800188	12	800195
6	800189	13	800196
7	800190	14	800197
8	800191	15	800198
9	800192	16	800199

PINCES ER32 JET

Ø D	Code	Ø D	Code
3	800200	12	800209
4	800201	13	800210
5	800202	14	800211
6	800203	15	800212
7	800204	16	800213
8	800205	17	800214
9	800206	18	800215
10	800207	19	800216
11	800208	20	800217

ATTACHEMENT | PINCES ÉTANCHES MÉCANIQUE - ER 16 | 20 | 25 | 32

PRÉCISION 0,008

PINCES ER16 ÉTANCHE MÉCANIQUE

Ø D	Code
3	800050
4	800051
5	800052
6	800053
7 *	800054
8	800055
9 *	800056
10	800057



PINCES ER20 ÉTANCHE MÉCANIQUE

Ø D	Code	Ø D	Code
3	800065	9 *	800071
4	800066	10	800072
5	800067	11 *	800073
6	800068	12	800074
7 *	800069	13 *	800075
8	800070		



PINCES ER32 ÉTANCHE MÉCANIQUE

Ø D	Code	Ø D	Code
3	800003	12	800012
4	800004	13 *	800013
5	800005	14	800014
6	800006	15 *	800015
7 *	800007	16	800016
8	800008	17 *	800017
9 *	800009	18	800018
10	800010	19 *	800019
11 *	800011	20	800020

PINCES ER25 ÉTANCHE MÉCANIQUE

Ø D	Code	Ø D	Code
3	800080	10	800087
4	800081	11 *	800088
5	800082	12	800089
6	800083	13 *	800090
7 *	800084	14	800091
8	800085	15 *	800092
9 *	800086	16	800093



PINCES ER40 ÉTANCHE MÉCANIQUE

* dans la limite des stocks disponibles

ATTACHEMENT | PINCES ETANCHES - ERGM 16 | 25 | 32 TARAUDAGE



PINCES ERGM 16

M	Ø D	Code
3	3,5	800218
3,5	4	800219
4	4,5	800220
4	5	800221
5	5,5	800222
5-6-8	6	800223
5-8	6,3	800224
7-10	7	800225

PINCES ERGM 25

M	Ø D	Code	M	Ø D	Code
3	3,5	800226	7-10	7	800233
3,5	4	800227	8	8	800234
4	4,5	800228	9-12	9	800235
4	5	800229	10	10	800236
5	5,5	800230	14	11	800237
5-6-8	6	800231	12	800238	
5-8	6,3	800232			

PINCES ERGM 32

M	Ø D	Code	M	Ø D	Code
3	3,5	800239	8	8	800247
3,5	4	800240	9-12	9	800248
4	4,5	800241	10	10	800249
4	5	800242	14	11	800250
5	5,5	800243	12	800251	
5-6-8	6	800244	18	14	800252
5-8	6,3	800245	20	16	800253
7-10	7	800246			

ATTACHEMENT | PINCES ETANCHES - 4SR32 | 6SSR12 | 6SR20

MANDRIN FORT SERRAGE 4SR32

Ø D	Code	Ø D	Code
6	800254	16	800264
7	800255	17	800265
8	800256	18	800266
9	800257	19	800267
10	800258	20	800268
11	800259	21	800269
12	800260	22	800270
13	800261	23	800271
14	800262	24	800272
15	800263	25	800273

0,005 MICRONS

MANDRIN HYDRAULIQUE 6SR12

Ø D	Code
3	800274
4	800275
5	800276
6	800277
7	800278
8	800279
10	800280

56 € HT

MANDRIN HYDRAULIQUE 6SR20

Ø D	Code	Ø D	Code
3	800281	11	800289
4	800282	12	800290
5	800283	13	800291
6	800284	14	800292
7	800285	15	800293
8	800286	16	800294
9	800287	17	800295
10	800288	18	800296

0,005 MICRONS

65 € HT



ATTACHEMENT | PINCES ETANCHE AVEC JOINT - ERXG 16 | 20 | 25 | 32

PRÉCISION 0,008



PINCES ÉTANCHE ERXG.16

Ø D	Code	Ø D	Code
3	427320B	7 *	427324B
4	427321B	8	427325B
5	427322B	9 *	427326B
6	427323B	10	427327B

PINCES ÉTANCHE ERXG.25

Ø D	Code	Ø D	Code	Ø D	Code
3	427585B	8	427590B	13 *	427595B
4	427586B	9 *	427591B	14	427596B
5	427587B	10	427592B	15 *	427597B
6	427588B	11*	427593B	16	427598B
7 *	427589B	12	427594B		



PINCES ÉTANCHE ERXG.20

Ø D	Code	Ø D	Code
3	427389B	9 *	427395B
4	427390B	10	427396B
5	427391B	11*	427397B
6	427392B	12	427398B
7 *	427393B	13*	427399B
8	427394B		

PINCES ÉTANCHE ERXG.32

Ø D	Code	Ø D	Code	Ø D	Code
4	427300B	10	427306B	16	427312B
5	427301B	11 *	427307B	17*	427313B
6	427302B	12	427308B	18	427314B
7 *	427303B	13 *	427309B	19*	427315B
8	427304B	14	427310B	20	427316B
9 *	427305B	15 *	427311B		

* dans la limite des stocks disponibles

ATTACHEMENT | PINCES TARAUDAGE - ERXM 32 | ER 32 | ERX MJT 32

PRÉCISION 0,015

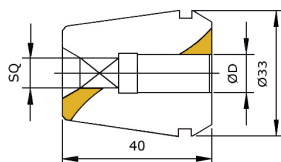

M	Ø D	SQ	Code	M	Ø D	SQ	Code
4	4,5	3,4	423760	12	9,0	7,0	423766
	5,0	4,0	423761	10	10,0	8,0	423767
	5,5	4,3	423762	14	11,0	9,0	423768
5-6	6,0	4,9	423763	16	12,0	9,0	423769
10x100	7,0	5,5	423764	18	14,0	11,0	423770
8	8,0	6,2	423765	20	16,0	12,0	423774

PINCES ER32 JET POUR ALÉSOIR

Ø D	Code
4	800124
5	800125
6	800126
7	800127
8	800128
9	800129
10	800130
11	800131
12	800132
13	800133
14	800134

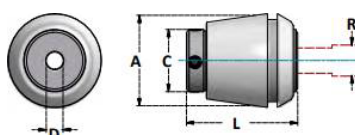

Articolo	R	C	A	L	D (mm)
ERC16PA	0,5	11	16	29	2 ÷ 7
ERC20PA	0,5	14	20	32	3 ÷ 8
ERC25PA	0,5	18,5	25	35	3 ÷ 10
ERC32PA	0,5	24	32	44	4 ÷ 14
ERC40PA	0,5	30	40	56	5 ÷ 16



PINCES ER32 COMPENSATION



M	Ø D	Code
4	4,5	423740
5-6	6	423741
10x100	7	423742
8	8	423743
12	9	423744
10	10	423745
14	11	423746

PINCES ER32 ÉTANCHE 4 TROUS ARROSEMENT FACE

Code	
4,5	423926
6	423927
7	423928
8	423929
9	423930
10	423931
11	423932
12	423933
14	423934
16	423935



MANDRIN HYDRAULIQUE EXTRA COURT ET ACCESSOIRES

MANDRIN HYDRAULIQUE SK40 | BT40

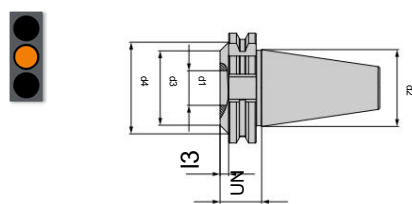

Référence	Code	d1	l3	A	Prix € net HT
SK 40 00 20 750 HDF	087663	20	5.4	24.5	290,00
BT 40 00 20 754 HDF	087664	20	5.5	32.5	290,00

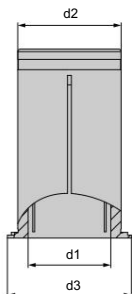

MANCHON DE RÉDUCTION

Référence D20	Code	Référence D32	Code	d1	l3	Prix D20 € net HT	Prix D32 € net HT
HDF20-03-IC	087665	-	-	3	4	98,00	-
HDF20-04-IC	087666	-	-	4	4	98,00	-
HDF20-05-IC	087667	-	-	5	4	98,00	-
HDF20-06-IC	087668	HDF32-06-IC	087674	6	4	77,00	98,00
HDF20-08-IC	087669	HDF32-08-IC	087675	8	4	77,00	98,00
HDF20-10-IC	087670	HDF32-10-IC	087676	10	4	77,00	98,00
HDF20-12-IC	087671	HDF32-12-IC	087677	12	4	77,00	98,00
HDF20-14-IC	087672	HDF32-14-IC	087678	14	4	77,00	98,00
HDF20-16-IC	087673	HDF32-16-IC	087679	16	4	77,00	98,00
-	-	HDF32-18-IC	087680	18	4	-	98,00
-	-	HDF32-20-IC	087681	20	4	-	98,00
-	-	HDF32-25-IC	087682	25	4	-	98,00

- Concentricité maximale
- Effet d'amortissement des vibrations
- Rigidité radiale élevée
- Serrage sans dispositifs supplémentaires
- Temps de réglage extrêmement rapide
- Plage flexible de 3 à 32 mm grâce à l'utilisation de douilles de réduction
- Force de serrage continue même à des vitesses élevées
- Sécurité de processus optimale
- Durée de vie maximale
- Compatible MQL
- Facilité d'entretien
- Gamme d'accessoires parfaitement adaptée
- Possibilité de serrage direct des queues lisses DIN6535HA, queues Weldon DIN6535HB et queues avec porte-outil WhistleNotch DIN6535HE (uniquement avec douille de réduction)

ADAPTATEUR CARBURE MONOBLOC



	Référence	d1	l3	Prix € net HT
M6	20 06 606/10 ZYL	6	20	225,20
	20 06 606/12 ZYL	6	20	253,24
	40 06 606/10 ZYL	6	40	241,42
	40 06 606/12 ZYL	6	40	270,50
	60 06 606/10 ZYL	6	60	261,81
	60 06 606/12 ZYL	6	60	299,57
	80 06 606/10 ZYL	6	80	288,80
	80 06 606/12 ZYL	6	80	316,83
M8	100 06 606/12 ZYL	6	100	344,76
	40 08 606	8	40	262,96
	60 08 606	8	60	289,85
	80 08 606	8	80	312,44
	100 08 606	8	100	336,18
M10	120 08 606	8	120	358,78
	60 10 606	10	60	332,94
	80 10 606	10	80	371,75
	100 10 606	10	100	408,36
	120 10 606	10	120	458,98
M12	140 10 606	10	140	511,81
	80 12 606	12	80	396,54
	100 12 606	12	100	485,97
	120 12 606	12	120	573,21
M16	140 12 606	12	140	661,60
	160 12 606	12	160	751,03
	100 16 606/32	16	100	815,67
	150 16 606/32	16	150	989,10
M16	200 16 606/32	16	200	1 192,75
	250 16 606/32	16	250	1 431,87
	300 16 606/32	16	300	1 637,62

ADAPTATEUR ANTIVIBRATION DENSE

	Référence	d1	l3	Prix € net HT
M8	40 08 601	8	40	188,59
	60 08 601	8	60	199,37
	80 08 601	8	80	210,14
	100 08 601	8	100	230,64
	120 08 601	8	120	248,95
M10	150 08 601	8	150	313,59
	60 10 601	10	60	219,87
	80 10 601	10	80	241,42
	100 10 601	10	100	266,21
M12	120 10 601	10	120	295,29
	140 10 601	10	140	348,00
	50 12 601	12	50	313,59
	75 12 601	12	75	326,46
	100 12 601	12	100	351,25
M16	125 12 601	12	125	374,99
	150 12 601	12	150	417,04
	175 12 601	12	175	471,96
	100 16 601/32	6	100	622,79
	150 16 601/32	6	150	778,96
M16	200 16 601/32	6	200	1 005,21
	250 16 601/32	6	250	1 129,16
	300 16 601/32	6	300	1 199,13

ATTACHEMENT | MANDRIN PORTE PINCES ER



pagnoni

EQUILIBRE 15 000 TRS/MN G2,5

- ER32
- GRANDE PRÉCISION $\leq 0,003$
- ARROSAGE CENTRAL

	L	Code	Prix promo € net HT
DIN 40	70	840054	35,00
BT 40	70	840353	35,00

sk
the μ -maker
SCHÜSSLER

EQUILIBRE 25 000 TRS/MN G2,5

- ER32
- GRANDE PRÉCISION $\leq 0,003$
- ARROSAGE CENTRAL

	L	Code	Prix promo € net HT
DIN 40	70	770060	74,80
BT 40	70	770065	73,00



EQUILIBRE 15 000 TRS/MN G2,5

- ER25
- GRANDE PRÉCISION $\leq 0,003$
- ARROSAGE CENTRAL

	L	Code	Prix promo € net HT
DIN 40	70	427235Z	32,00
BT 40	70	427236Z	32,00

EQUILIBRE 20 000 TRS/MN G2,5

- ER32
- GRANDE PRÉCISION $\leq 0,003$
- ARROSAGE CENTRAL

	L	Code	Prix promo € net HT
DIN 40	70	427217Z	40,00
BT 40	70	427216Z	40,00

serinex
CNC TOOLHOLDER SYSTEM

EQUILIBRE 15 000 TRS/MN G2,5

- ER16
- GRANDE PRÉCISION $\leq 0,003$
- ARROSAGE CENTRAL

	L	Code	Prix promo € net HT
DIN 40	70	427482Z	32,00
BT 40	70	427483Z	32,00

EQUILIBRE 15 000 TRS/MN G2,5

- ER32
- GRANDE PRÉCISION $\leq 0,003$
- ARROSAGE CENTRAL

	L	Code	Prix promo € net HT
DIN 40	70	427222Z	32,00
BT 40	70	427221Z	32,00

Le saviez-vous ?

Disponibles jusqu'en
longueur 200

ATTACHEMENT | PORTE PINCES QUEUE CYLINDRIQUE

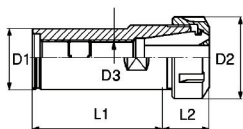

TYPE	CAP	D1	D2	D3	L1	L2	Code	Prix promo € net HT
32 NC ER32	2	20	32	50	22 x 1,5	80	427230B	48,00
40 NC ER32	2	20	40	50	22 x 1,5	80	427231B	48,00

ATTACHEMENT | DOUILLE DE RÉDUCTION CYLINDRIQUE



D	L	D1	Code
		6	427570B
		8	427571B
		10	427572B
32	90	12	427573B
		16	427574B
		20	427575B
		25	427576B

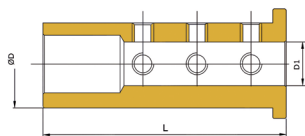

D	L	D1	Code
		8	427930B
		10	427931B
		12	427932B
40	80	16	427933B
		20	427934B
		25	427935B
		32	427936B

34
€ HT

34
€ HT

ATTACHEMENT | RALLONGE PORTE PINCES | ER - ECROU MINI



TYPE	CAP	D	D1	L	Code	Prix promo € net HT	TYPE	CAP	D	D1	L	Code	Prix promo € net HT
ER8	1 5	12	12	100	870001	30,00	ER16	1 10	22	12	80	870007	30,00
ER11	1 7	16	8	55	870002	30,00	ER16	1 10	22	16	80	870008	30,00
ER11	1 7	16	10	60	870003	30,00	ER16	1 10	22	16	130	870009	30,00
ER11	1 7	16	12	70	870004	30,00	ER16	1 10	22	20	100	870010	30,00
ER11	1 7	16	16	100	870005	30,00	ER16	1 10	22	20	160	870011	30,00
ER16	1 10	22	10	80	870006	30,00							

ATTACHEMENT | MANDRINS À PINCES - PSC6

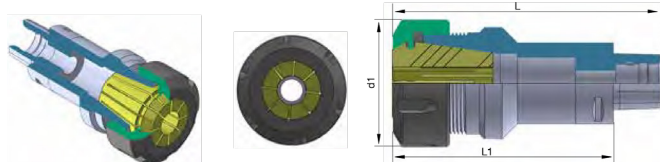

Mandrin à pinces - PSC6



Désignation	L1	Equilibrage	Code	Prix promo € HT
MANDRIN A PINCE PSC6 ER16	100	G2,5 25000	427013	152,15
MANDRIN A PINCE PSC6 ER20	60	G2,5 25000	427014	152,15
MANDRIN A PINCE PSC6 ER20	100	G2,5 25000	427015	152,15
MANDRIN A PINCE PSC6 ER25	60	G2,5 25000	427016	152,15
MANDRIN A PINCE PSC6 ER25	100	G2,5 25000	427017	152,15
MANDRIN A PINCE PSC6 ER32	70	G2,5 25000	427018	152,15
MANDRIN A PINCE PSC6 ER32	100	G2,5 25000	427019	152,15
MANDRIN A PINCE PSC6 ER40	65	G2,5 25000	427020	152,15

PORTE PINCES HAWK EYE

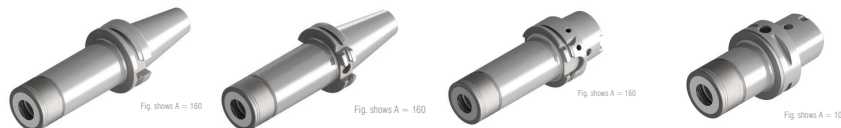

Plage de serrage	ER	D	A	BT40		SK40		HSK63		C6	
				Code	Prix promo € net HT	Code	Prix promo € net HT	Code	Prix promo € net HT	Code	Prix promo € net HT
1-10	16	34	70/75	770230	112,80	770218	112,80	770200	134,40		
2-20	32	52	70/75	770231	118,40	770219	118,40	770201	144,80		
1-10	16	34	100	770232	124,00	770220	124,00	770202	141,60	770242	183,20
2-20	32	52	100	770233	130,40	770221	130,40	770203	149,60	770243	246,40
1-10	16	34	130	770234	136,80	770222	136,80	770204	155,20		
2-20	32	52	130	770235	144,80	770223	144,80	770205	164,80		
1-10	16	34	160	770236	151,20	770224	151,20	770206	174,40		
2-20	32	52	160	770237	158,40	770225	158,40	770207	183,20		

ATTACHEMENT | MANDRIN FORT SERRAGE

PORTE-PINCES BT40

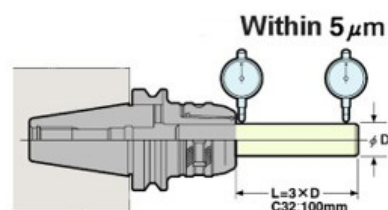

Désignation	Référence fournisseur	Code	Prix promo € net HT
PORTE-PINCE BT40	BT40-C20-90	090993	429,30
PORTE-PINCE BT40	BT40-C32-105	090994	444,60

ATTACHEMENT | CLE DYNAMOMETRIQUE



CLÉ DYNAMOMÉTRIQUE STD

CLÉ DYNAMOMÉTRIQUE MINI

Type	Article	Code	Prix promo € net HT	Type	Article	Code	Prix promo € net HT
CLE DYNAMOMETRIQUE STD ER16	WR.DIN.16	427532Z	85,00	CLE DYNAMOMETRIQUE ER8 MINI	WR.DIN.8.MINI	427537Z	45,00
CLE DYNAMOMETRIQUE STD ER20	WR.DIN.20	427533Z	85,00	CLE DYNAMOMETRIQUE ER11 MINI	WR.DIN.11.MINI	427538Z	45,00
CLE DYNAMOMETRIQUE STD ER25	WR.DIN.25	427534Z	85,00	CLE DYNAMOMETRIQUE ER16 MINI	WR.DIN.16.MINI	427539Z	45,00
CLE DYNAMOMETRIQUE STD ER32	WR.DIN.32	427535Z	85,00	CLE DYNAMOMETRIQUE ER20 MINI	WR.DIN.20.MINI	427541Z	45,00
CLE DYNAMOMETRIQUE STD ER40	WR.DIN.40	427536Z	85,00	CLE DYNAMOMETRIQUE ER25 MINI	WR.DIN.25.MINI	427542Z	45,00



Type	Diamètre	Article	Code	Prix promo € net HT
CLE DYNAMOMETRIQUE DMK 100	20 - 100	2641232	418006	261,91
CLE DYNAMOMETRIQUE DMUK 100	20 - 100	2641305	418001	361,89

ATTACHEMENT | MANDRIN PORTE-FRAISE - PSC6

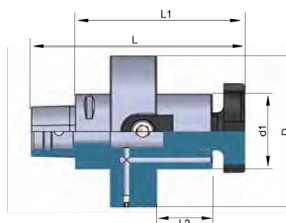
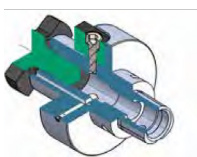

PSC6

Désignation	Ø	L1	Equilibrage	Code	Prix promo € net HT
MANDRIN PORTE FRAISE PSC6	16	35	G2,5 25000	427021	157,44
MANDRIN PORTE FRAISE PSC6	22	40	G2,5 25000	427022	157,44
MANDRIN PORTE FRAISE PSC6	27	40	G2,5 25000	427023	157,44
MANDRIN PORTE FRAISE PSC6	32	40	G2,5 25000	427024	157,44
MANDRIN PORTE FRAISE PSC6	40	45	G2,5 25000	427025	157,44

ATTACHEMENT | MANDRIN PORTE-FRAISE | TROU LISSE

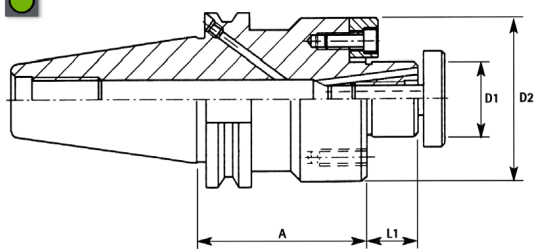

ARROSAGE CENTRE
| AUTRE LONGUEUR SUR DEMANDE |

	A	D1	D2	L1	Code	Prix promo € net HT
DIN 40	45	16	38	17	840118	48,85
	45	22	48	19	840119	48,85
	50	27	58	21	840120	48,85
	55	32	66	24	840121	51,17
	55	40	80	27	840122	55,96
BT 40	45	16	38	17	840417	48,85
	45	22	48	19	840418	48,85
	45	27	58	21	840419	48,85
	50	32	78	24	840420	51,17
	55	40	88	27	840421	55,96

ÉQUILIBRAGE 15 000 TRS/MN G6,3

• GRANDE PRÉCISION $\leq 0,003$

ATTACHEMENT | MANDRIN PORTE-FRAISE | À QUEUE FILETÉE

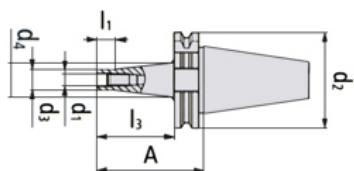

EQUILIBRE 20 000 TRS/MN G2,5

• GRANDE PRÉCISION $\leq 0,003$

	D	D1	D3	D4	L3	L1	Code	Prix promo € net HT
DIN 40	M8	8,5	13,8	15	25	12	087338	98,22
	M10	10,5	18	23	25	12	087339	98,22
	M12	12,5	21	24	25	12	087340	98,22
	M16	17,0	29	29	25	12	087341	98,22
BT 40	M8	8,5	13,8	15	25	12	087364	98,22
	M10	10,5	18	23	25	12	087367	98,22
	M12	12,5	21	24	25	12	087370	98,22
	M16	17,0	29	9	25	12	087373	98,22



LONGUEURS 50 - 70 - 100 EN STOCK | PRIX SUR DEMANDE

ATTACHEMENT | MANDRIN WELDON - PSC6 | MANDRINS À PINCES - PSC6

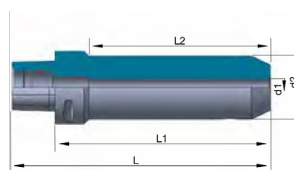

Mandrin Weldon - PSC6



Désignation	Ø	L1	Equilibrage	Code	Prix promo € HT
MANDRIN WELDON PSC6 D6	6	55	G2,5 25000	427026	147,02
MANDRIN WELDON PSC6 D8	8	55	G2,5 25000	427027	147,02
MANDRIN WELDON PSC6 D10	10	60	G2,5 25000	427028	147,02
MANDRIN WELDON PSC6 D12	12	60	G2,5 25000	427029	147,02
MANDRIN WELDON PSC6 D14	14	60	G2,5 25000	427030	147,02
MANDRIN WELDON PSC6 D16	16	65	G2,5 25000	427031	147,02
MANDRIN WELDON PSC6 D18	18	65	G2,5 25000	427032	147,02
MANDRIN WELDON PSC6 D20	20	65	G2,5 25000	427033	147,02
MANDRIN WELDON PSC6 D25	25	80	G2,5 25000	427034	147,02
MANDRIN WELDON PSC6 D32	32	90	G2,5 25000	427035	147,02
MANDRIN WELDON PSC6 D40	40	100	G2,5 25000	427036	147,02

ATTACHEMENT | MANDRIN POUR SCIE CIRCULAIRE

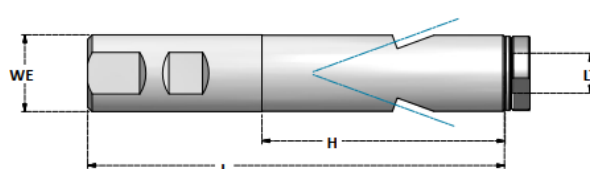
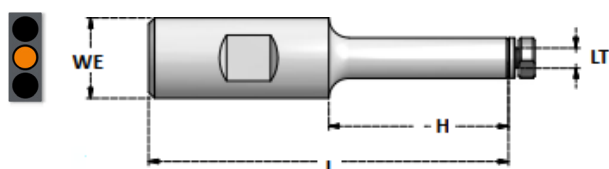

WE25-13LT | WE25-16LT

Désignation	WE	LT	H	L	Référence	Code	Prix tarif € HT
MANDRIN POUR SCIE CIRCULAIRE	20	5	40	90	WE20-5LT	840811	99,20
MANDRIN POUR SCIE CIRCULAIRE	20	8	49	100	WE20-8LT	840812	102,60
MANDRIN POUR SCIE CIRCULAIRE	20	10	59	110	WE20-10LT	840813	107,60
MANDRIN POUR SCIE CIRCULAIRE	25	13	79	136	WE25-13LT	840814	116,90
MANDRIN POUR SCIE CIRCULAIRE	25	16	79	136	WE25-16LT	840815	120,80

ATTACHEMENT | MANDRIN WELDON ARROSAGE CENTRE ET FACE

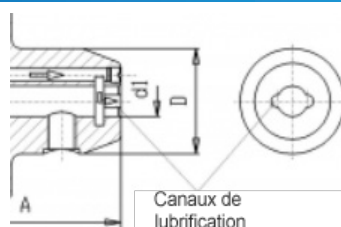
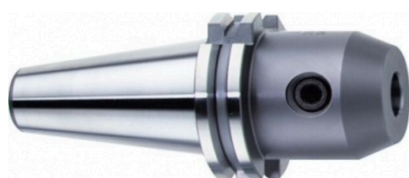

Désignation	Référence fournisseur	Code	Prix promo € HT	
MAND WELD DIN40 D6 10000TR/G6,3	ARROSAGE FACE +AD+B	SK40	446360	70,00
MAND WELD DIN40 D8 10000TR/G6,3	ARROSAGE FACE +AD+B	SK40	446362	70,00
MAND WELD DIN40 D10 10000TR/G6,3	ARROSAGE FACE +AD+B	SK40	446364	70,00
MAND WELD DIN40 D12 10000TR/G6,3	ARROSAGE FACE +AD+B	SK40	446366	70,00
MAND WELD DIN40 D14 10000TR/G6,3	ARROSAGE FACE +AD+B	SK40	446368	70,00
MAND WELD DIN40 D16 10000TR/G6,3	ARROSAGE FACE +AD+B	SK40	446370	70,00
MAND WELD DIN40 D18 10000TR/G6,3	ARROSAGE FACE +AD+B	SK40	446372	70,00
MAND WELD DIN40 D20 10000TR/G6,3	ARROSAGE FACE +AD+B	SK40	446374	70,00
MAND WELD DIN40 D25 10000TR/G6,3	ARROSAGE FACE +AD+B	SK40	446376	70,00

ATTACHEMENT | MANDRIN WELDON ARROSAGE CENTRE ET FACE

Désignation	Référence fournisseur	Code	Prix promo € HT	
MAND WELDON ISO40 MAS403BT	H50 D.06 AD	AFB340WLK06	840826	55,00
MAND WELDON ISO40 MAS403BT	H50 D.08 AD	AFB340WLK08	840827	52,00
MAND WELDON ISO40 MAS403BT	H63 D.10 AD	AFB340WLK10	840828	52,00
MAND WELDON ISO40 MAS403BT	H63 D.12 AD	AFB340WLK12	840829	52,00
MAND WELDON ISO40 MAS403BT	H63 D.14 AD	AFB340WLK14	840830	52,00
MAND WELDON ISO40 MAS403BT	H63 D.16 AD	AFB340WLK16	840831	52,00
MAND WELDON ISO40 MAS403BT	H63 D.18 AD	AFB340WLK18	840832	52,00
MAND WELDON ISO40 MAS403BT	H63 D.20 AD	AFB340WLK20	840833	52,00
MAND WELDON ISO40 MAS403BT	H90 D.25 AD	AFB340WLK25	840834	61,00
MAND WELDON ISO40 MAS403BT	H100 D.32 AD	AFB340WLK32	840835	72,00
MAND WELDON ISO40 MAS403BT	H107 D.40 AD	AFB340WLK40	840836	85,00



ATTACHEMENT | MANDRIN WELDON ARROSAGE CENTRE ET FACE

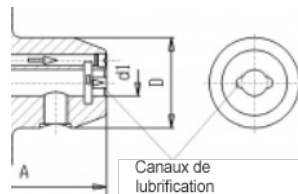

Désignation	Référence fournisseur	Code	Prix promo € HT	
MAND WELD BT40 D6 10000TR/G6,3	ARROSAGE FACE +AD+B	BT40	446390	62,97
MAND WELD BT40 D8 10000TR/G6,3	ARROSAGE FACE +AD+B	BT40	446392	62,97
MAND WELD BT40 D10 10000TR/G6,3	ARROSAGE FACE +AD+B	BT40	446394	62,97
MAND WELD BT40 D12 10000TR/G6,3	ARROSAGE FACE +AD+B	BT40	446396	62,97
MAND WELD BT40 D14 10000TR/G6,3	ARROSAGE FACE +AD+B	BT40	446398	62,97
MAND WELD BT40 D16 10000TR/G6,3	ARROSAGE FACE +AD+B	BT40	446400	74,33
MAND WELD BT40 D18 10000TR/G6,3	ARROSAGE FACE +AD+B	BT40	446402	74,33
MAND WELD BT40 D20 10000TR/G6,3	ARROSAGE FACE +AD+B	BT40	446404	74,33
MAND WELD BT40 D25 10000TR/G6,3	ARROSAGE FACE +AD+B	BT40	446408	74,33



pagnoni

serinex
CNC TOOLHOLDER SYSTEM



	Désignation	Equilibrage	Code	Prix promo € HT	Code	Prix promo € HT
DIN 40	MAND WELDON DIN40 D6 L50 P	G2.5 15000 tr/mn			446306Z	31,00
	MAND WELDON DIN40 D8 L50 P	G2.5 15000 tr/mn	840005	33,00	446308Z	31,00
	MAND WELDON DIN40 D10 L50 P	G2.5 15000 tr/mn	840006	33,00	446310Z	31,00
	MAND WELDON DIN40 D12 L50 P	G2.5 15000 tr/mn	840007	33,00	446312Z	31,00
	MAND WELDON DIN40 D14 L50 P	G2.5 15000 tr/mn	840008	33,00	446314Z	31,00
	MAND WELDON DIN40 D16 L63 P	G2.5 15000 tr/mn	840009	33,00	446316Z	31,00
	MAND WELDON DIN40 D18 L63 P	G2.5 15000 tr/mn	840010	33,00	446318Z	31,00
	MAND WELDON DIN40 D20 L63 P	G2.5 15000 tr/mn	840011	33,00	446320Z	31,00
	MAND WELDON DIN40 D25 L100 P	G2.5 15000 tr/mn			446325Z	31,00
	MAND WELDON DIN40 D32 L100 P	G2.5 15000 tr/mn			446332Z	31,00
BT 40	MAND WELDON BT40 D6 L50 P	G2.5 15000 tr/mn			446106Z	31,00
	MAND WELDON BT40 D8 L50 P	G2.5 15000 tr/mn	840304	33,00	446108Z	31,00
	MAND WELDON BT40 D10 L65 P	G2.5 15000 tr/mn	840305	33,00	446110Z	31,00
	MAND WELDON BT40 D12 L65 P	G2.5 15000 tr/mn	840306	33,00	446112Z	31,00
	MAND WELDON BT40 D14 L63 P	G2.5 15000 tr/mn	840307	33,00	446114Z	31,00
	MAND WELDON BT40 D16 L63 P	G2.5 15000 tr/mn	840308	33,00	446116Z	31,00
	MAND WELDON BT40 D18 L70 P	G2.5 15000 tr/mn	840309	33,00	446118Z	31,00
	MAND WELDON BT40 D20 L70 P	G2.5 15000 tr/mn	840310	33,00	446120Z	31,00
	MAND WELDON BT40 D25 L100 P	G2.5 15000 tr/mn			446125Z	31,00
	MAND WELDON BT40 D32 L100 P	G2.5 15000 tr/mn			446132Z	31,00

| AUTRE LONGUEUR SUR DEMANDE |



Désignation	Référence fournisseur	Code	Prix promo € HT	
MAND WELDON ISO40 DIN69871	H50 D.6 AD	AFB140WLK06	840816	52,95
MAND WELDON ISO40 DIN69871	H50 D.8 AD	AFB140WLK08	840817	50,40
MAND WELDON ISO40 DIN69871	H50 D.10 AD	AFB140WLK10	840818	50,40
MAND WELDON ISO40 DIN69871	H50 D.12 AD	AFB140WLK12	840819	50,40
MAND WELDON ISO40 DIN69871	H50 D.14 AD	AFB140WLK14	840820	50,40
MAND WELDON ISO40 DIN69871	H63 D.16 AD	AFB140WLK16	840821	50,40
MAND WELDON ISO40 DIN69871	H63 D.18 AD	AFB140WLK18	840822	50,40
MAND WELDON ISO40 DIN69871	H63 D.20 AD	AFB140WLK20	840823	50,40
MAND WELDON ISO40 DIN69871	H100 D.25 AD	AFB140WLK25	840824	61,00
MAND WELDON ISO40 DIN69871	H100 D.32 AD	AFB140WLK32	840825	61,00

ATTACHEMENT | MANDRINS DE FRETTAGE



	D	L	Code	Prix promo € net HT
BT 40	3	90	770036	123,33
	4	90	770037	123,33
	6	90	770005	95,33
	8	90	770007	95,33
	10	90	770009	95,33
	12	90	770011	95,33
	16	90	770015	95,33
	20	90	770019	95,33
DIN 40	4	80	740023	112,00
	5	80	740024	112,00
	6	80	740006	90,00
	8	80	740008	90,00
	10	80	740010	90,00
	12	80	740012	90,00
	16	80	740016	90,00
HSK63A	6	80	730017	102,00
	8	80	730018	102,00
	10	85	730019	102,00
	16	95	730010	102,00
	20	100	730012	102,00

EQUILIBRE 25 000 TRS/MN G2,5

• GRANDE PRÉCISION ≤0,003

	D	L	Code	Prix promo € net HT
DIN 40	6	80	740006W	73,00
	8	80	740008W	73,00
	10	80	740010W	73,00
	12	80	740012W	73,00
	14	80	740014W	73,00
	16	80	740016W	73,00
	18	80	740018W	73,00
	20	80	740020W	73,00
BT 40	6	90	770005W	73,00
	8	90	770007W	73,00
	10	90	770009W	73,00
	12	90	770011W	73,00
	14	90	770013W	73,00
	16	90	770015W	73,00
	18	90	770017W	73,00
	20	90	770019W	73,00

EQUILIBRE 25 000 TRS/MN G2,5

• GRANDE PRÉCISION ≤0,003

ATTACHEMENT | MANDRINS DE FRETTAGE

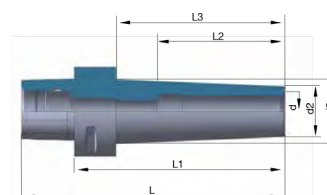

PSC6

Désignation	Ø	L1	Equilibrage	Code	Prix promo € HT
MANDRIN FRETTAGE PSC6	8	80	G2,5 25000	427004	173,64
MANDRIN FRETTAGE PSC6	10	80	G2,5 25000	427005	173,64
MANDRIN FRETTAGE PSC6	12	80	G2,5 25000	427006	173,64
MANDRIN FRETTAGE PSC6	14	85	G2,5 25000	427007	173,64
MANDRIN FRETTAGE PSC6	16	85	G2,5 25000	427008	173,64
MANDRIN FRETTAGE PSC6	18	85	G2,5 25000	427009	173,64
MANDRIN FRETTAGE PSC6	20	85	G2,5 25000	427010	173,64
MANDRIN FRETTAGE PSC6	25	90	G2,5 25000	427011	173,64
MANDRIN FRETTAGE PSC6	32	95	G2,5 25000	427012	173,64

Diamètres 3, 4, 5, 6 disponibles sur demande

ATTACHEMENT | MANDRINS DE FRETTAGE FIN

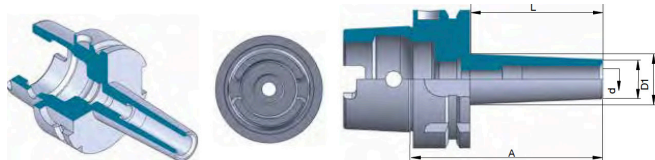

D	A	D1	D	L	Désignation	Référence	Code	Prix promo € HT
6	90	12	17	61	SLIM TYPE HSK63A H90 CL6	HSK.A.63.90.CL6.SL	740165	98,00
8	90	14	19	64	SLIM TYPE HSK63A H90 CL8	HSK.A.63.90.CL8.SL	740166	98,00
10	90	16	21	64	SLIM TYPE HSK63A H90 CL10	HSK.A.63.90.CL10.SL	740167	98,00
12	90	18	23	64	SLIM TYPE HSK63A H90 CL12	HSK.A.63.90.CL12.SL	740168	98,00
14	90	18	23	64	SLIM TYPE HSK63A H90 CL14	HSK.A.63.90.CL14.SL	740169	98,00
16	95	24	29	64	SLIM TYPE HSK63A H95 CL16	HSK.A.63.95.CL16.SL	740170	98,00
20	100	32	39	74	SLIM TYPE HSK63A H100 CL20	HSK.A.63.100.CL20.SL	740185	98,00

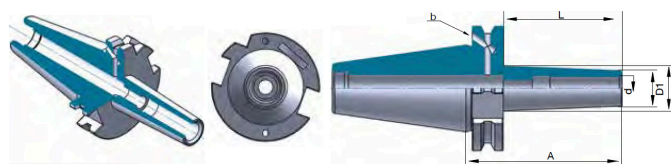

D	A	D1	D	L	Désignation	Référence	Code	Prix promo € HT
6	80	12	17	61	SLIM TYPE TCB40 H80 CL6	SKB.40.80.CL6.SL	740171	85,00
8	80	14	19	60,9	SLIM TYPE TCB40 H80 CL8	SKB.40.80.CL8.SL	740172	85,00
10	80	16	21	60,9	SLIM TYPE TCB40 H80 CL10	SKB.40.80.CL10.SL	740173	85,00
12	80	18	23	60,9	SLIM TYPE TCB40 H80 CL12	SKB.40.80.CL12.SL	740174	85,00
14	80	22	25	60,9	SLIM TYPE TCB40 H80 CL14	SKB.40.80.CL14.SL	740175	85,00
16	80	24	29	60,9	SLIM TYPE TCB40 H80 CL16	SKB.40.80.CL16.SL	740176	85,00
20	80	32	39	60,9	SLIM TYPE TCB40 H80 CL20	SKB.40.80.CL20.SL	740177	85,00

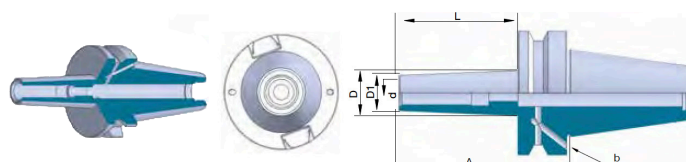

D	A	D1	D	L	Désignation	Référence	Code	Prix promo € HT
6	90	12	17	63	SLIM TYPE BTB40 H90 CL6	BTB.40.90.CL6.SL	740178	85,00
8	90	14	19	63	SLIM TYPE BTB40 H90 CL8	BTB.40.90.CL8.SL	740179	85,00
10	90	16	21	63	SLIM TYPE BTB40 H90 CL10	BTB.40.90.CL10.SL	740180	85,00
12	90	18	23	63	SLIM TYPE BTB40 H90 CL12	BTB.40.90.CL12.SL	740181	85,00
14	90	22	25	63	SLIM TYPE BTB40 H90 CL14	BTB.40.90.CL14.SL	740182	85,00
16	90	24	29	63	SLIM TYPE BTB40 H90 CL16	BTB.40.90.CL16.SL	740183	85,00
20	90	28	33	63	SLIM TYPE BTB40 H90 CL20	BTB.40.90.CL20.SL	740184	85,00

ATTACHEMENT | DEMONTE CONE ORIENTABLE



CONES	Code	Prix promo € net HT
CONE 40 HSK63A CAPTO C6	840800	127,28
CONE 50 HSK100 CAPTO C10	840801	135,69

PORTE-OUTILS EXPANSIBLE HYDRAULIQUE



TENDO E compact	HSK-A 63	SK 40	BT 30	BT 40	SCHUNK CAPTO C 6
Référence	0299970	0299969	0299934	0299968	0299986
Code article	428687	428688	428689	428690	428691
Prix tarif € HT	407,00	407,00	456,00	407,00	613,00

Le starter kit TENDO E compact comprend :

- 1 x TENDO E compact (au choix HSK-A 63 dia. 20, SK 40 dia. 20, BT 30 dia. 20, BT 40 dia. 20, SCHUNK CAPTO C 6 dia. 20)
- 5 x Douilles GZB-S dia. 20 (avec diamètre de serrage 6, 8, 10, 12, 16) étanches au liquide de coupe jusqu'à 80 bar
- 1 x Extracteur de douilles
- 1 x Clé d'actionnement
- 1 x Coffret exclusif

ATTACHEMENTS COOLCAP



Prix sur demande

Clé universelle pour tous les écrous CoolCap - à commander



SK 40



Référence	d1	I3	A	Code	Prix Fretage € net HT	Code	Prix Weldon € net HT
50 04 750 SR1	4	50	69,1	087610	233,80	-	-
50 06 750 SR1	6	50	69,1	087611	233,80	-	-
50 08 750 SR1	8	50	69,1	087612	233,80	-	-
50 10 750 SR1 /W	10	50	69,1	087613	233,80	087617	233,80
60 12 750 SR1 /W	12	60	79,1	087614	233,80	087618	233,80
60 16 750 SR1 /W	16	60	79,1	087615	233,80	087619	233,80
60 20 750 SR1 /W	20	60	79,1	087616	233,80	087620	233,80

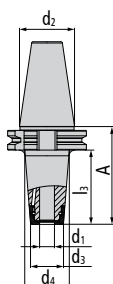

BT 40 MAS BT



Référence	d1	I3	A	Code	Prix Fretage € net HT	Code	Prix Weldon € net HT
50 06 754 SR1	6	50	77	087621	233,80	-	-
50 08 754 SR1	8	50	77	087622	233,80	-	-
50 10 754 SR1 /W	10	50	77	087623	233,80	087626	233,80
50 12 754 SR1 /W	12	60	87	087624	233,80	087627	233,80
60 16 754 SR1 /W	16	60	87	087625	233,80	087628	233,80

HSK 63 FORM A

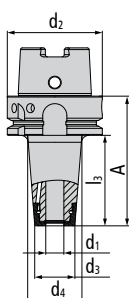

Référence	d1	I3	A	Code	Prix Fretage € net HT	Code	Prix Weldon € net HT
50 04 A63 SR1	4	50	76	087629	233,80	-	-
50 06 A63 SR1	6	50	76	087630	274,70	-	-
50 08 A63 SR1	8	50	76	087631	262,70	-	-
50 10 A63 SR1 /W	10	50	76	087632	262,70	087636	262,70
60 12 A63 SR1 /W	12	60	86	087633	262,70	087637	262,70
60 16 A63 SR1 /W	16	60	86	087634	262,70	087638	262,70
60 20 A63 SR1 /W	20	60	86	087635	262,70	087639	262,70

Coiffe offerte

Offre n° 2025-1005007

ATTACHEMENT | ADAPTATEUR CAPTO



HSK.A - CAPTO ADAPTER



BTB - CAPTO ADAPTER



SKB - CAPTO ADAPTER



CAPTO - CAPTO ADAPTER DIFFERENT DIAMETERS



Désignation	Référence	Code	€ promo ht
Adaptateur HSK63A-CPT40 H80 CAPTO C4	HSK.A.63.80.CPT40	427037	136,98
Adaptateur HSK63A-CPT50 H90 CAPTO C5	HSK.A.63.90.CPT50	427038	136,98
Adaptateur HSK100A-CPT40 H90 CAPTO C4	HSK.A.100.90.CPT40	427039	206,29
Adaptateur HSK100A-CPT50 H100 CAPTO C5	HSK.A.100.100.CPT50	427040	206,29
Adaptateur HSK100A-CPT63 H110 CAPTO C6	HSK.A.100.110.CPT63	427041	206,29
Adaptateur HSK100A-CPT80 H120 CAPTO C8	HSK.A.100.120.CPT80	427042	218,71
Adaptateur HSK100A-CPT100 H155 CAPTO C10	HSK.A.100.155.CPT100	427043	330,06
Adaptateur BTB40-CPT40 H30 CAPTO C4	BTB.40.30.CPT40	427056	136,98
Adaptateur BTB40-CPT50 H50 CAPTO C5	BTB.40.50.CPT50	427057	136,98
Adaptateur BTB40-CPT63 H75 CAPTO C6	BTB.40.75.CPT63	427058	136,98
Adaptateur BTB50-CPT40 H40 CAPTO C4	BTB.50.40.CPT40	427059	198,05
Adaptateur BTB50-CPT50 H40 CAPTO C5	BTB.50.40.CPT50	427060	198,05
Adaptateur BTB50-CPT63 H50 CAPTO C6	BTB.50.50.CPT63	427061	198,05
Adaptateur BTB50-CPT80 H70 CAPTO C8	BTB.50.70.CPT80	427062	218,71
Adaptateur BTB50-CPT100 H140 CAPTO C10	BTB.50.140.CPT100	427063	247,55
Adaptateur SKB40-CPT40 H30 CAPTO C4	SKB.40.30.CPT40	427064	136,98
Adaptateur SKB40-CPT50 H40 CAPTO C5	SKB.40.40.CPT50	427065	136,98
Adaptateur SKB40-CPT63 H85 CAPTO C6	SKB.40.85.CPT63	427066	136,98
Adaptateur SKB50-CPT40 H30 CAPTO C40	SKB.50.30.CPT40	427067	198,05
Adaptateur SKB50-CPT50 H30 CAPTO C50	SKB.50.30.CPT50	427068	198,05
Adaptateur SKB50-CPT63 H50 CAPTO C63	SKB.50.50.CPT63	427069	198,05
Adaptateur SKB50-CPT80 H70 CAPTO C80	SKB.50.70.CPT80	427070	218,71
Adaptateur SKB50-CPT100 H140 CAPTO C100	SKB.50.140.CPT100	427071	313,57
REDUCTION CAPTO CPT100-CPT80 L200	CPT.100.200.RID80	427081	371,32

ACCESSOIRES | OUTILS DE MOLETAGE

OUTIL DE MOLETAGE PAR COUPE | MF 21.55.20 - MF 21.55.25

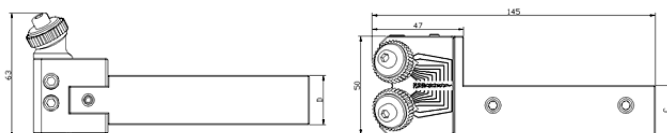

OUTIL DE MOLETAGE	VERSION	CAPACITÉ	MOLETTE	C	D	RÉFÉRENCE	CODE	Prix tarif € HT
OUTIL DE MOLETAGE - MF 21.55.20	R + L	∅ 5÷250	21.5X5X8	20	25	1100500	055000	535,00
OUTIL DE MOLETAGE - MF 21.55.25	R + L	∅ 5÷250	21.5X5X8	25	25	1100700	055001	535,00

CARACTÉRISTIQUES :

- Réglage symétrique de la position des molettes pour l'ajuster au diamètre de la pièce au moyen d'une broche filetée
- Possibilité de travailler à droite et à gauche en variant la position de la tête
- Tête ajustable en hauteur pour un meilleur alignement des molettes
- Possibilité de correction de l'angle d'attaque
- Indiquée uniquement pour des moletages longitudinaux (F)

TYPES DE MACHINE : TOURS AUTOMATIQUES | MULTIBROCHES | CONVENTIONNELLES | CNC
PIÈCE DE RECHANGE : EAT 21.55

MOLETES

POUR MOLETAGE PAR COUPE HRc 61±1 standard :

- Molettes suivant DIN 403 pour moletages suivant DIN82
- Matériel standard: HSS sans recouvrement
- Fournies aussi bien biseautées que sans biseauter
- Vaste gamme de matériels et recouvrements disponibles
Surfaces latérales et orifice rectifiés

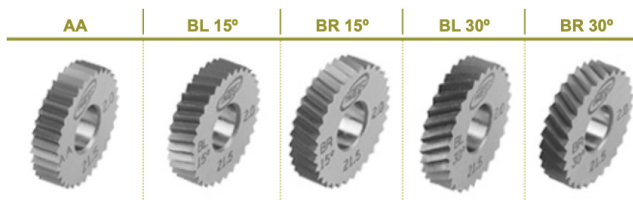

MAINTENANCE | FILTRES POUR MACHINES - OUTILS



1 rouleau de Velum =
2 ans de protection totale

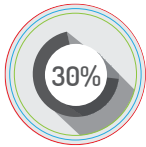

Réduit les coûts
d'entretien de 30%



Empêche la propagation
de particules nocives



Pas de temps d'arrêt
de la machine



Protégez votre entreprise
avec 20 centimes par jour

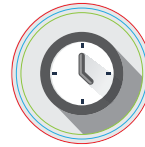

Remplacement
en 5 secondes

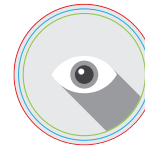

Contrôle visuel permettant
de savoir quand le filtre
doit être changé



Pas d'ouverture
de l'appareil électrique

FILTRE VELUM

INDIQUÉ POUR LA PROTECTION DE CADRES ÉLECTRIQUES



CHAQUE ROULEAU EST COMPOSÉ DE 110 FEUILLES

FILTRE VELUM	Codes	Code	Prix unitaire € net HT
VELUM 200 FILTRE 200 MM	VELFIL000200.01	438003	33,50
VELUM 300 FILTRE 300 MM	VELFIL000300.01	438000	59,00
VELUM 400 FILTRE 400 MM	VELFIL000400.01	438001	68,00
VELUM 500 FILTRE 500 MM	VELFIL000500.01	438002	77,00
VELUM 600 FILTRE 600 MM	VELFIL000600.01	438004	86,00

FILTRE VELUM AIR	Codes	Code	Prix unitaire € net HT
VELUM AIR 200 FILTRE 200 MM	VELAIRFIL200.01	438010	35,00
VELUM AIR 300 FILTRE 300 MM	VELAIRFIL300.01	438011	62,00
VELUM AIR 400 FILTRE 400 MM	VELAIRFIL400.01	438012	71,50
VELUM AIR 500 FILTRE 500 MM	VELAIRFIL500.01	438013	81,00
VELUM AIR 600 FILTRE 600 MM	VELAIRFIL600.01	438014	90,00

FILTRE VELUM AIR

POUR LA PROTECTION D'ÉCHANGEURS DE CHALEUR |
DE CLIMATISEURS | DE COMPRESSEURS



CHAQUE ROULEAU EST COMPOSÉ DE 60 FEUILLES

FILTRE VELUM MOTOR

POUR LA PROTECTION DE MOTEURS ÉLECTRIQUES



CHAQUE FILTRE CONTIENT :

- 1 SUPPORT EN PLASTIQUE COMPLET AVEC LES AIMANTS
- 1-O RING
- 12 FILTRES

FILTRE VELUM AIR	Codes	Code	Prix unitaire € net HT
VELUM MOTOR 100 FILTRE Ø 100MM	VELMOT000100.01	438020	38,00
VELUM MOTOR 120 FILTRE Ø 120MM	VELMOT000120.01	438021	40,00
VELUM MOTOR 150 FILTRE Ø 150MM	VELMOT000150.01	438022	46,00
VELUM MOTOR 175 FILTRE Ø 175MM	VELMOT000175.01	438023	50,00
VELUM MOTOR 200 FILTRE Ø200MM	VELMOT000200.01	438024	54,00
VELUM MOTOR 230 FILTRE Ø230MM	VELMOT000230.01	438025	62,00
VELUM MOTOR 260 FILTRE Ø260MM	VELMOT000260.01	438026	68,00
VELUM MOTOR 300 FILTRE Ø 300MM	VELMOT000300.01	438027	74,00

installation



replacement



PRISE PIÈCES | ÉTAUX MÉTRIQUE - REHAUSSE POUR ÉTAUX



SYSTÈME DE SERRAGE POINT ZÉRO CentroLite 68K I-Gripp b67

Pour platine entraxe
52x52

À partir de
576 €
HT

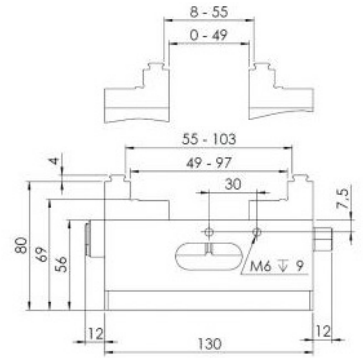
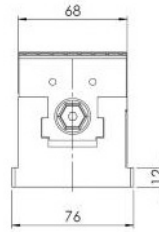
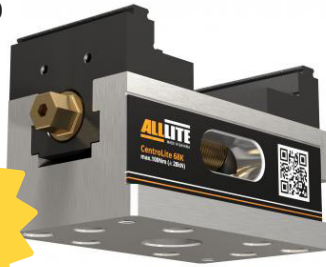

SYSTÈME DE SERRAGE POINT ZÉRO CentroLite 125M I-Gripp b124

Pour platine entraxe
96x96

À partir de
867 €
HT

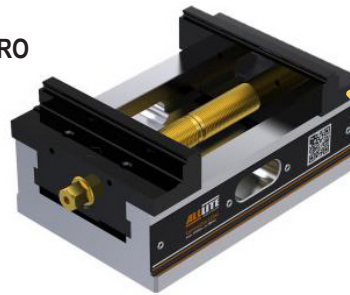

À partir de
430 €
HT

SYSTÈME DE BRIDAGE POINT ZÉRO CentroLite 68M



SERVANTES ET SUPPORTS CONES

SUPPORT ÉTABLI

Outils	Places	Référence	Code	Promo € net ht
SK30/BT30	24	WZ-WR3K2-SK30	403001	294,80
SK40/BT40	21	WZ-WR3K2-SK40	403002	294,80
SK50/BT50	15	WZ-WR3K2-SK50	403003	294,80
HSK63	18	WZ-WR3K2-HSK63	403004	312,70



RACK CONES

Outils	Places	Référence	Code	Promo € net ht
SK30/BT30	8	WZ-WRK2-SK30	403005	87,60
SK40/BT40	7	WZ-WRK2-SK40	403006	87,60
SK50/BT50	6	WZ-WRK2-SK50	403007	87,60
HSK63	6	WZ-WRK2-HSK63	403008	94,60

SUPPORT CONES

Outils	Référence	Code	Promo € net ht
SK30/BT30	WZ-R2-SK30	403009	8,00
SK40/BT40	WZ-R2-SK40	403010	8,00
SK50/BT50	WZ-R2-SK50	403011	8,00
HSK63	WZ-R2-HSK63	403012	8,00



SERVANTE COMPLÈTE

Outils	Places	kg	Référence	Code	Promo € net ht
SK30/BT30	32	51	WZ-WW-SK30	403013	621,60
SK40/BT40	28	51	WZ-WW-SK40	403014	621,60
SK50/BT50	20	51	WZ-WW-SK50	403015	621,60
HSK63	24	51	WZ-WW-HSK63	403016	621,60



PRISE PIÈCES | ÉTAUX DE PRÉCISION - ÉTAUX GAMMES CLG

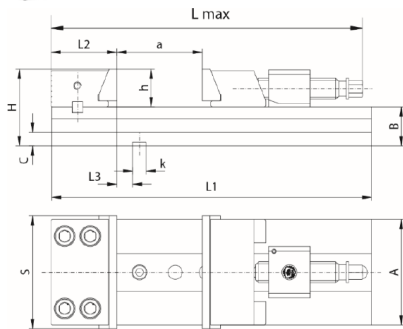
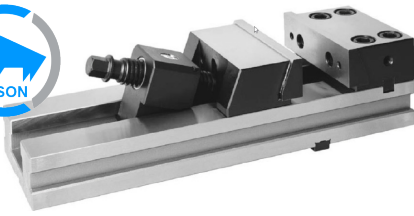

a	S	h	L1	Référence fournisseur	Code	Prix promo € net HT
165	100	30	320	326620010600	412048	836,10
165	125	40	335	326620030000	412049	1003,31
210	150	50	425	326620050300	412050	1273,43
260	150	50	475	326620060500	412051	1318,45
260	200	60	535	326620100500	412052	1903,71
310	200	60	585	326620110700	412053	1929,44
360	200	60	635	326620120900	412054	2058,07

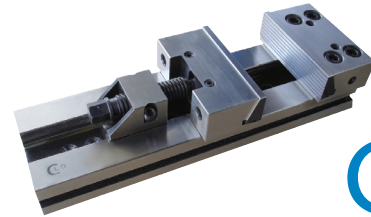

ETAUX CLG	Largeur	Hauteur semelle	Ouverture	Longueur semelle	Hauteur mors	Code	Prix promo € net HT
ETAU CLG 100X150	100	35	150	320	30	415009	387,00
ETAU CLG 125X150	125	40	150	345	40	415003	343,00
ETAU CLG 150X200	150	50	200	420	50	415001	480,00
ETAU CLG 150X300	150	50	300	520	50	415005	530,00
ETAU CLG 150X400	150	50	400	620	50	415012	827,00
ETAU CLG 200X300	200	70	300	595	65	415002	885,00
ETAU CLG 200X400	200	70	400	695	65	415004	1019,00



PRISE PIÈCES | LARDONS ÉTAUX

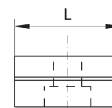
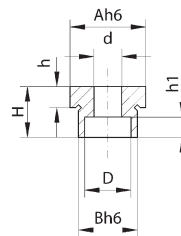

Dim.	Référence	Code	Prix promo € net HT
18 x 22	14-18-22	412235C	69,60
18 x 20	14-18-20	412236C	69,60
18 x 18	14-18-18	412237C	27,40
18 x 16	14-18-16	412238C	69,60
18 x 14	14-18-14	412239C	69,60
14 x 14	14-14-14	412249C	27,30
14 x 18	14-14-18	412250C	69,60
14 x 20	14-14-20	412251C	69,60
14 x 22	14-14-22	412252C	69,60
16 x 12	14-16-12	412253C	35,80
16 x 14	14-16-14	412254C	35,80
16 x 16	14-16-16	412255C	27,30
16 x 18	14-16-18	412256C	35,80
16 x 20	14-16-20	412257C	35,80
16 x 22	14-16-22	412258C	35,80
16 x 24	14-16-24	412259C	69,60
16 x 36	14-16-36	412261C	69,60
18 x 12	14-18-12	412262C	69,60
20 x 22	14-20-22	412267C	74,60
22 x 14	14-22-14	412268C	74,60
22 x 16	14-22-16	412269C	74,60
22 x 18	14-22-18	412270C	74,60
22 x 20	14-22-20	412271C	74,60
22 x 22	14-22-22	412274C	47,20



COFFRETS CALES DE FRAISAGE	Code	Prix promo € net HT
COFFRET DE 18 CALES DE FRAISAGE PRECISION H +/- 0,01 LARGEUR +/- 0,5 CLG 100X4	415070A	55,00
COFFRET DE 16 CALES DE FRAISAGE PRECISION H +/- 0,01 LARGEUR +/- 0,5 CLG 120X8	415078A	55,00
COFFRET DE 18 CALES DE FRAISAGE PRECISION H +/- 0,01 LARGEUR +/- 0,5 CLG 160X4	415072A	55,00
COFFRET DE 16 CALES DE FRAISAGE PRECISION H +/- 0,01 LARGEUR +/- 0,5 CLG 160X8	415074A	82,00
COFFRET DE 16 CALES DE FRAISAGE PRECISION H +/- 0,01 LARGEUR +/- 0,5 CLG 200X8	415076A	92,00

| LES CALES NE SONT RECTIFIÉES QUE SUR DEUX FACES |

Conditionnement : 2 pièces

ACCESSOIRES DYNAMOMÉTRIQUES



Désignation	Article	Code	Prix tarif € HT
TORX CLIX S-handle dynamometrique 2,5 Nm	SG25	087640	16,80
TORX CLIX T-handle dynamometrique 5,5 Nm	TG55	087641	25,70



Désignation	Article	Code	Prix tarif € HT
Tige Torx T6	T06-R	087651	21,20
Tige Torx T7	T07-R	087652	21,20
Tige Torx T8	T08-R	087653	21,20
Tige Torx T9	T09-R	087654	21,20
Tige Torx T10	T10-R	087655	21,20
Tige Torx T15	T15-R	087656	21,20
Tige Torx T20	T20-R	087657	21,20



Désignation	Article	Code	Prix tarif € HT
Adaptateur de couple Torx 0,4 Nm	DM04	087642	29,10
Adaptateur de couple Torx 0,6 Nm	DM06	087643	29,10
Adaptateur de couple Torx 0,9 Nm	DM09	087644	29,10
Adaptateur de couple Torx 1,0 Nm	DM10	087645	29,10
Adaptateur de couple Torx 1,5 Nm	DM15	087646	29,10
Adaptateur de couple Torx 2,2 Nm	DM22	087647	29,10
Adaptateur de couple Torx 2,5 Nm	DM25	087648	29,10
Adaptateur de couple Torx 3,8 Nm	DM38	087649	29,10
Adaptateur de couple Torx 5,5 Nm	DM55	087650	29,10

Désignation	Article	Code	Prix tarif € HT
Tige Torx Plus T6	TP06-R	087658	21,20
Tige Torx Plus T7	TP07-R	087659	21,20
Tige Torx Plus T8	TP08-R	087660	21,20
Tige Torx Plus T9	TP09-R	087661	21,20
Tige Torx Plus T15	TP15-R	087662	19,87

PRISE PIÈCES | KIT TOURNEVIS DINAPLUS

KITDP00000

REF 420536
290 € HT



KIT DINAPLUS
DYNAPLUS KIT
DYNAPLUS KIT
KIT DINAPLUS

ART. 26000

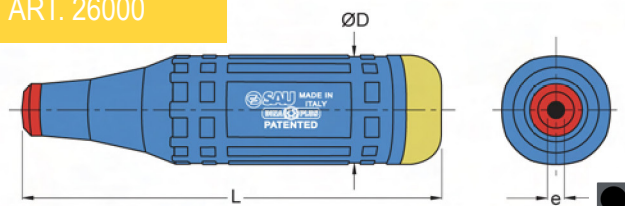

MANICO CACCIAVITE DINAPLUS
DYNAPLUS SCREWDRIVER HANDLE
DYNAPLUS SCHRAUBENDREHER-GRIF
MANCHE TOURNEVIS DYNAPLUS



CONTENU DU KIT

- n°1 TORX T6 (Nm0,6)
- n°1 TORX T7 (Nm0,9)
- n°1 TORX T8 (Nm1,2)
- n°1 TORX T9 (Nm1,4)
- n°1 TORX T10 (Nm2,0)
- n°1 TORX T15 (Nm3,0)
- n°1 TORX T20 (Nm5,0)
- n°1 TORX PLUS IP6 (Nm0,6)
- n°1 TORX PLUS IP7 (Nm0,9)
- n°1 TORX PLUS IP8 (Nm1,2)
- n°1 TORX PLUS IP9 (Nm1,4)
- n°1 TORX PLUS IP10 (Nm2,0)
- n°1 TORX PLUS IP15 (Nm3,0)
- n°1 TORX PLUS IP20 (Nm5,0)

ART.	(mm) e	ØD	L
26000	7,3	33,2	131,4
270../290..			

ART. 270..

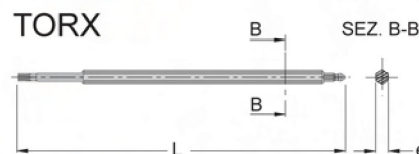

LAMA INTERCAMBIABILE
INTERCHANGEABLE BLADE
AUSTAUSCHBARES MESSER
LAME INTERCHANGEABLE

ART. 290..

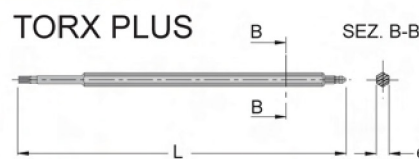

LAMA INTERCAMBIABILE
INTERCHANGEABLE BLADE
AUSTAUSCHBARES MESSER
LAME INTERCHANGEABLE

Articles 420537 à 420552

ART.	(mm) Torx Plus	e	L	Nm ^{Max}	TIPO TYPE
27006	6	6,3	175	0,6	Torx LAME TORX 12,48€ HT
27007	7	6,3	175	0,9	
27008	8	6,3	175	1,2	
27009	9	6,3	175	1,4	
27010	10	6,3	175	2,0	
27015	15	6,3	175	3,0	
27020	20	6,3	175	5,0	
29006	6IP	6,3	175	0,6	Torx Plus LAME TORX PLUS 12,48€ HT
29007	7IP	6,3	175	0,9	
29008	8IP	6,3	175	1,2	
29009	9IP	6,3	175	1,4	
29010	10IP	6,3	175	2,0	
29015	15IP	6,3	175	3,0	
29020	20IP	6,3	175	5,0	



APPAREILS À TARAUDER

BROCHE À CHANGEMENT RAPIDE

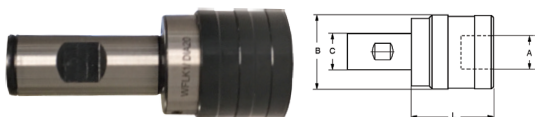

TYPE	CAP.	ADAP.	ØA	ØB	ØC	L	EXTEN.	COMP.	Code	Prix tarif € HT
1 SC	M3-M12	CR1 LC1 RB1	19	36	20	39	7,5	7,5	423185A	200,00

DOUILLES D19 (M3 - M12)

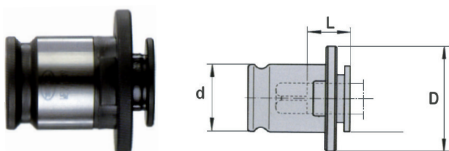

TYPE	Ø TARAUD	ØQ TARAUD	d	D	L	Code	Prix tarif € HT	
CR1	M4,5-M10	4-11,2	19	30	7			
TYPE	Ø NOMINAL	DIN 371	DIN 374 / DIN 376					
CR1	M4,5 - 5	3,5 x 2,7	19	30	7	423392A	19,66	
CR1	M6	4,5 x 3,4	19	30	7	423393A	19,66	
CR1	M8	6 x 4,9	19	30	7	423395A	19,66	
CR1	M7	7 x 5,5	19	30	7	423387A	19,66	
CR1	M8	8 x 6,2	19	30	7	423388A	19,66	
CR1	M9	9 x 7	19	30	7	423389A	19,66	
CR1	M10	10 x 8	19	30	7	423382A	28,60	



1 BROCHE À CHANGEMENT RAPIDE (M3 - 12) ACHETÉE = 6 DOUILLES D19 (M3 - M12) OFFERTES

POLISSAGE | ENSEMBLE DE MEULAGE ET POLISSAGE



SMD30LR | EFFICACITÉ, LÉGÈRETÉE ET CONFORT RÉUNIS DANS UN SEUL PRODUIT

- 30 000 TR/MIN
- ANTI-VIBRATIONS
- PINCES DE 6 MM



365975
513,41 €
HT

SPM60LR et SPM80LR | L'ÉVOLUTION D'UN BEST-SELLER

- 60 000 TR/MIN ET 80 000 TR/MIN
- PINCES DE 3 MM



SPM60LR	365974	376,75 €
SPM80LR	365971	344,06 €



116120L



116100L



116110L



116130L

Article	Code	Prix promo € net HT
116100L	428320	122,91
116110L	428322	155,18
116120L	428323	157,50
116130L	428325	159,92



BROSSES EXPANSIBLES ROUGES

Aluminium et acier



Ø du trou	Ø brosse	Longueur	Attach. Ø	Vitesse maxi RPM	Référence	Code	Prix € net HT
3 - 5 mm	1,5 mm	120	3 x 30	18 000	A1215M	190000	44,16
5 - 8 mm	3 mm	120	3 x 30	10 000	A1230M	190001	44,16
8 - 10 mm	5 mm	120	6 x 30	10 000	A1250M	190002	60,18
10 - 16 mm	7 mm	120	6 x 30	10 000	A1270M	190054	86,95
14 - 20 mm	11 mm	120	12 x 30	8 000	A1211M	190055	95,10
5 - 8 mm	3 mm	170	3 x 30	10 000	A1230L	190056	77,57
8 - 10 mm	5 mm	170	6 x 30	10 000	A1250L	190057	99,37
10 - 16 mm	7 mm	170	6 x 30	10 000	A1270L	190058	131,66
14 - 20 mm	11 mm	180	12 x 30	8 000	A1211L	190059	133,60

BROSSES EXPANSIBLES BLEUES

Inox, titane et inconel



Ø du trou	Ø brosse	Longueur	Attach. Ø	Vitesse maxi RPM	Référence	Code	Prix € net HT
5 - 8 mm	3 mm	130	4 x 30	14 000	A3303M	190060	48,56
8 - 10 mm	5 mm	130	6 x 30	14 000	A3305M	190061	66,14
10 - 14 mm	7 mm	130	6 x 30	14 000	A3307M	190062	95,52
14 - 20 mm	11 mm	130	12 x 30	12 000	A3311M	190063	111,10
5 - 8 mm	3 mm	180	4 x 30	12 000	A3303L	190064	85,21
8 - 10 mm	5 mm	180	6 x 30	12 000	A3305L	190065	108,68
10 - 14 mm	7 mm	180	6 x 30	12 000	A3307L	190066	143,78
14 - 20 mm	11 mm	180	12 x 30	10 000	A3311L	190067	156,45

Ebavurage de trous sécants sur centre d'usinage

Utilisation :

- Rotation arrêtée, insérer la brosse dans le trou à ébavurer.
- Démarrer la broche.
- Exécuter des mouvements de broche (environ (300 mm / min).
- Arrêter la rotation avant de sortir la brosse.

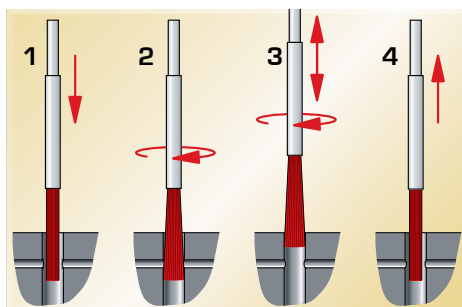

MACHINE DE MARQUAGE



Ecran OLED

Informations en temps réel

Niveau de batterie, état de la connexion wifi, fichier de marquage en cours...



Autonome en énergie

Batterie Lithium Ion 22V intégrée

- Autonomie suffisante pour une journée de marquage
- Conception spécifique de la batterie pour une meilleure combinaison électronique/batterie/logiciel
- Légèreté, performance et durabilité garanties

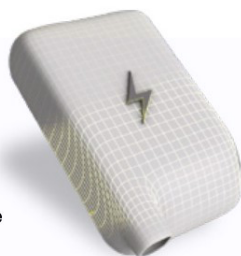

Dock de rangement

- Support de tête avec fixation sur établi
- Rangement pour stylets, ressorts et casquette
- Maintenance : vérification de l'état des ressorts et de l'angle d'affutage des stylets



BUDDY

Machine micro-percussion sans fil
Pilotée par smartphone



PRIX
SUR DEMANDE



5 en 1

- Antidérapant
- Appui magnétique grâce aux aimants
- Marquage sur pièces planes
- Marquage sur petits et grands cylindres grâce aux deux paires de V de centrage
- Aide au positionnement grâce à la casquette

MACHINE DE MARQUAGE | ÉLECTROLYTIQUE

- Résistance mécanique et chimique supérieures aux systèmes laser et à la sérigraphie,
- Rapidité
- Résistance à la corrosion : la partie marquée est plus résistante que le métal de base
- Garantie de pouvoir produire des logos et des marques de grandes dimensions même sur des épaisseurs minces, sans risquer aucune déformation
- Qualité des détails particuliers comparable à la définition obtenue par le laser
- Flexibilité maximale, avec la possibilité d'utiliser les pochoirs multifonction ou de produire des pochoirs jetables grâce au "kit imprimante".

ACIER INOXYDABLE STAINLESS STEEL	■	■
ACIER AU CARBONE CARBON STEEL	■	■
ACIER GALVANISÉ GALVANIZED STEEL	■	■
ACIER CHROMÉ CHROME STEEL	■	■
PLASTIQUE CHROMÉE CHROME PLASTIC	■	■
ALUMINIUM ALUMINIUM	■	■
TITANE TITANIUM	■	■
CUIVRE COPPER	■	■
LAITON BRASS	■	■



PATENT
PENDING

Grâce à un procédé spécial étant breveté, Multi Mark est la première machine au monde capable de faire le marquage en noir sur aluminium.



438035
1 435 €
HT



438036
575 €
HT



PINULE MÉCANIQUE ET MAGNÉTIQUE / RÉGLET INOX



001001000



001010400



001TIN010



001TIN104



Description	Article	Diam. queue	Diam. testeur	Code	Prix promo € net HT
PINULE ECO	0010010EP	Ø10	Ø10	592020A	10,00
PINULE ECO	001010AEP	Ø10	Ø10 / Ø4	592006A	10,00
PINULE MECANIQUE	001001000	Ø10	Ø10	592027	39,90
PINULE MECANIQUE	001010400	Ø10	Ø10 / Ø4	592028	39,90
PINULE AMAGNETIQUE TIN	001TIN010	Ø10	Ø10	592026	92,40
PINULE AMAGNETIQUE TIN	001TIN104	Ø10	Ø10 - Ø4	592025	110,25

Dimensions	Référence	Code	€ promo ht
150X13	R17101	501002	2,60
200X13	R17102	501003	4,20
300X13	R17104	501005	7,40

BUTÉE STANDARD ET MAGNÉTIQUE



003420150



003420001



003420002



Description	Article	Code	Prix tarif € net HT
BUTÉE STANDARD 5D	003420150	472015	133,42
BUTÉE MAGNETIQUE FLEXIMAG	003420001	472030	107,15
BUTÉE MAGNETIQUE EASYMAG	003420002	472031	57,25

DISPOSITIF DE MISE À ZÉRO



Description	Article	Diam. corps	Diam. testeur	Code	Prix promo € net HT
DISPOSITIF DE MISE À ZÉRO - MICRO 100 mm	002400100	Ø54,5	Ø42	592040	280,02
DISPOSITIF DE MISE À ZÉRO MAGNET - MICRO 100 mm	002402100	Ø54,5	Ø42	592041	343,13
DISPOSITIF DE MISE À ZÉRO MAGNET - MICRO 50 mm	002102000	Ø65	Ø47	554051	404,28
ADAPTATEUR H50 POUR H100	002105000	Ø65	Ø47	554052	98,47
DISPOSITIF DE MISE À ZÉRO - MICRO 50 mm	002101000	Ø65	Ø47	554053	263,77



LEVAGE | PORTEUR MAGNÉTIQUE ET AIMANT DE LEVAGE



Capacité	100 KG	300 KG	500 KG	1 000 KG
Code	438074E	438075E	438076E	438077E
Prix	215,51	401,42	572,00	971,89

TÊTES RENVOI D'ANGLE



TÊTES RENVOI D'ANGLE - SÉRIE CP

Ces têtes sont adaptées pour des opérations de perçage, taraudage et alésage. Des adaptations sur mesure sont disponibles pour de nombreuses machines.



PRISE PIÈCES | PLATEAU À DÉPRESSION ET MAGNÉTIQUE

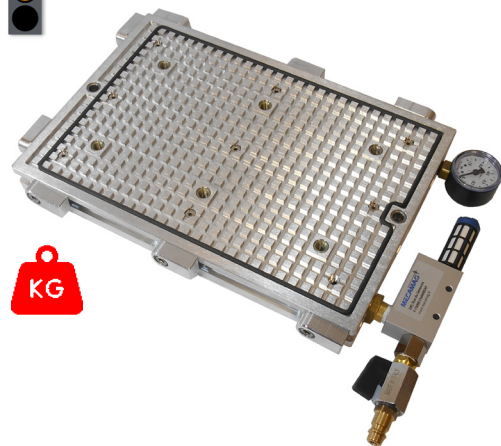

PLATEAU ALUMINIUM À DÉPRESSION À GRILLE AVEC VENTURI

L	I	H	Pas de grille	Référence fournisseur	Code
300	200	30	10 x 10	5001/11/300X200V	438028
400	300	30	10 x 10	5001/11/400X300V	438029
600	400	30	10 x 10	5001/11/600X400V	438030

A partir de
805 €
net ht

CARACTÉRISTIQUES :

- Aluminium massif
 - Planéité et parallélisme : +/-0.01/100 mm
 - Grille pour joint de 4 mm au pas de 10 x 10 mm
 - Nombreuses zones d'aspiration avec bouchons obturateurs
 - Inserts inox M8 au pas de 100 x 100 mm pour bridage mécanique éventuel
 - Butées excentriques sur deux côtés
- Utilisation également possible avec un groupe de vide pour une plus grande force de bridage

LIVRÉ AVEC 4 BRIDES | 2 RÈGLES À RAINURER (LONGUEUR 140MM) | JOINT | TAPIS D'OBTURATION | INDICATEUR DE VIDE ET VENTURI (AIR COMPRIMÉ SAC À 3.5 BARS ET 100L/MM MINIMUM)

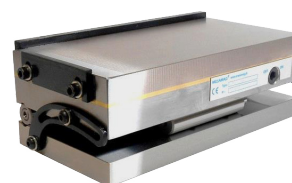
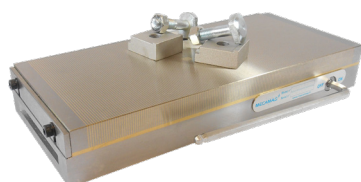

PLATEAU MAGNÉTIQUE

Dimensions	Référence fournisseur	Code
175X100	2001/01/175100	438050
250X130	2001/01/250130	438051
350X150	2001/01/350150	438053
400X150	2001/01/350150	438054

A partir de
630 €
net ht



PLATEAU MAGNÉTIQUE SINUS

Dimensions	Référence fournisseur	Code
175X100	2031/06/175100	438070
150X150	2031/06/150150	438071
250X125	2031/06/250125	438072
300X150	2031/0/300150	438073

A partir de
1 020 €
net ht



OUTILS DE BROCHAGE



Tolérances spéciales
possibles

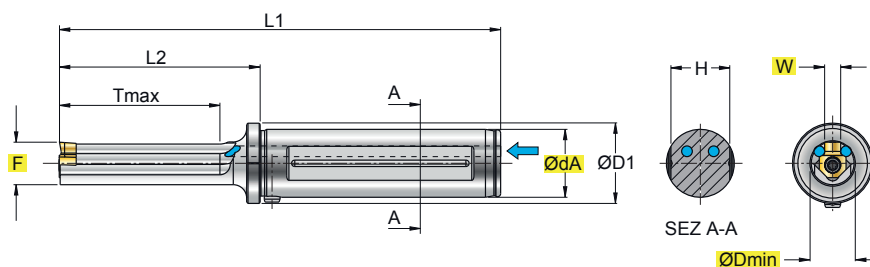

Description	Article	W	F	Diam. min	Diam. dA	Tmax	Prix promo € net HT
OUTILS DE BROCHAGE	S686.030.030.025	3	9,0	9,5	25	30	119,16
OUTILS DE BROCHAGE	S686.030.040.025	3	9,0	9,5	25	40	119,16
OUTILS DE BROCHAGE	S686.030.030.032	3	9,0	9,5	32	30	122,73
OUTILS DE BROCHAGE	S686.030.040.032	3	9,0	9,5	32	40	122,73
OUTILS DE BROCHAGE	S686.040-050.040.025	04-05	10,0	10,9-11,2	25	40	125,34
OUTILS DE BROCHAGE	S686.040-050.060.025	04-05	10,0	10,9-11,2	25	60	125,34
OUTILS DE BROCHAGE	S686.040-050.040.032	04-05	10,0	10,9-11,2	32	40	129,78
OUTILS DE BROCHAGE	S686.040-050.060.032	04-05	10,0	10,9-11,2	32	60	129,78
OUTILS DE BROCHAGE	S686.060-080.060.025	06-08	15,9	17-17,5	25	60	131,60
OUTILS DE BROCHAGE	S686.060-080.100.025	06-08	15,9	17-17,5	25	100	131,60
OUTILS DE BROCHAGE	S686.060-080.060.032	06-08	15,9	17-17,5	32	60	140,40
OUTILS DE BROCHAGE	S686.060-080.100.032	06-08	15,9	17-17,5	32	100	140,40
OUTILS DE BROCHAGE	S686.100-120.080.025	10-12	22,4	24-24,5	25	80	174,78
OUTILS DE BROCHAGE	S686.100-120.140.025	10-12	22,4	24-24,5	25	140	174,78
OUTILS DE BROCHAGE	S686.100-120.080.032	10-12	22,4	24-24,5	32	80	184,53
OUTILS DE BROCHAGE	S686.100-120.140.032	10-12	22,4	24-24,5	32	140	184,53

Description	Article	Toll.	HC F7230	sans HC F7230
			Prix promo € HT	Prix promo € HT
PLAQUETTE OUTILS DE BROCHAGE	SLT 030-0604 H7	(3,000-3,010)	41,14	
PLAQUETTE OUTILS DE BROCHAGE	SLT 030-0604 D10	(3,020-3,060)	41,14	
PLAQUETTE OUTILS DE BROCHAGE	SLT 030-0604 C11	(3,060-3,120)	39,22	
PLAQUETTE OUTILS DE BROCHAGE	SLT 040-0604 H7	(4,000-4,012)	41,83	
PLAQUETTE OUTILS DE BROCHAGE	SLT 040-0604 D10	(4,030-4,078)	41,83	
PLAQUETTE OUTILS DE BROCHAGE	SLT 040-0604 C11	(4,070-4,145)	39,48	
PLAQUETTE OUTILS DE BROCHAGE	SLT 050-0604 H7	(5,000-5,012)	42,44	
PLAQUETTE OUTILS DE BROCHAGE	SLT 050-0604 D10	(5,030-5,078)	42,44	
PLAQUETTE OUTILS DE BROCHAGE	SLT 050-0604 C11	(5,070-5,145)	40,18	
PLAQUETTE OUTILS DE BROCHAGE	SLT 060-1006 H7	(6,000-6,012)	53,86	56,82
PLAQUETTE OUTILS DE BROCHAGE	SLT 060-1006 D10	(6,030-6,078)	53,86	56,82
PLAQUETTE OUTILS DE BROCHAGE	SLT 060-1006 C11	(6,070-6,145)	51,86	53,95
PLAQUETTE OUTILS DE BROCHAGE	SLT 080-1006 H7	(8,000-8,015)	54,73	56,82
PLAQUETTE OUTILS DE BROCHAGE	SLT 080-1006 D10	(8,040-8,098)	54,73	56,82
PLAQUETTE OUTILS DE BROCHAGE	SLT 080-1006 C11	(8,080-8,170)	52,64	53,95
PLAQUETTE OUTILS DE BROCHAGE	SLT 100-1309 H7	(10,000-10,015)	63,71	70,25
PLAQUETTE OUTILS DE BROCHAGE	SLT 100-1309 D10	(10,040-10,098)	63,71	70,25
PLAQUETTE OUTILS DE BROCHAGE	SLT 100-1309 C11	(10,080-10,170)	61,97	68,33
PLAQUETTE OUTILS DE BROCHAGE	SLT 120-1309 H7	(12,000-12,018)	64,67	70,25
PLAQUETTE OUTILS DE BROCHAGE	SLT 120-1309 D10	(12,050-12,120)	64,67	70,25
PLAQUETTE OUTILS DE BROCHAGE	SLT 120-1309 C11	(12,050-12,120)	62,75	68,33

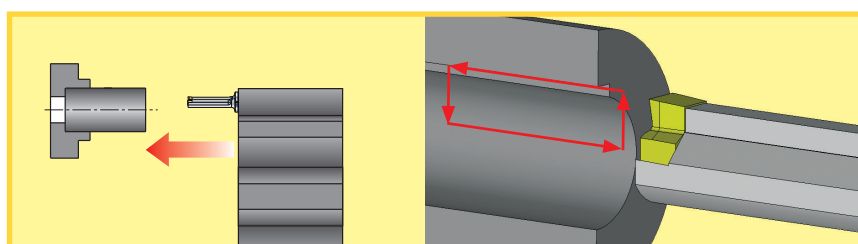



VDI B1

Description	Référence	Code	Prix promo € HT
PO VDI FORME B1 D30X20X40	92B1 302040	621301W	55,00
PO VDI FORME B1 D40X25X44	92B1 402544	621401W	68,00
PO VDI FORME B1 D50X32X55	92B1 503255	621501W	92,00
PO VDI FORME B1 D60X32X60	92B1 603260	621601W	143,00

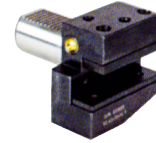

VDI B2

Description	Référence	Code	Prix promo € HT
PO VDI FORME B2 D30X20X40	92B2 302040	622301W	59,00
PO VDI FORME B2 D40X25X44	92B2 402544	622401W	69,00
PO VDI FORME B2 D50X32X55	92B2 503255	622501W	99,00
PO VDI FORME B2 D60X32X60	92B2 603260	622601W	141,00



VDI B3

Description	Référence	Code	Prix promo € HT
PO VDI FORME B3 D30X20X40	92B3 302040	623301W	64,00
PO VDI FORME B3 D40X25X44	92B3 402544	623401W	69,00
PO VDI FORME B3 D50X32X55	92B3 503255	623501W	115,00
PO VDI FORME B3 D60X32X60	92B3 603260	623601W	155,00



VDI B4

Description	Référence	Code	Prix promo € HT
PO VDI FORME B4 D30X20X40	92B4 302040	624301W	64,00
PO VDI FORME B4 D40X25X44	92B4 402544	624401W	69,00
PO VDI FORME B4 D50X32X55	92B4 503255	624501W	119,00
PO VDI FORME B4 D60X32X60	92B4 603260	624601W	141,00



VDI B5

Description	Référence	Code	Prix promo € HT
PO VDI FORME B5 D30X20X40	92B5 302040	625301W	73,00
PO VDI FORME B5 D40X25X44	92B5 402544	625401W	82,00
PO VDI FORME B5 D50X32X55	92B5 503255	625501W	119,00
PO VDI FORME B5 D60X32X60	92B5 603260	625601W	168,00



VDI B6

Description	Référence	Code	Prix promo € HT
PO VDI FORME B6 D30X20X40	92B6 302040	626301W	73,00
PO VDI FORME B6 D40X25X44	92B6 402544	626401W	86,00
PO VDI FORME B6 D50X32X55	92B6 503255	626501W	119,00
PO VDI FORME B6 D60X32X60	92B6 603260	626601W	168,00



VDI B7

Description	Référence	Code	Prix promo € HT
PO VDI FORME B7 D30X20X40	92B7 302040	627301W	76,00
PO VDI FORME B7 D40X25X44	92B7 402544	627401W	88,00
PO VDI FORME B7 D50X32X55	92B7 503255	627501W	135,00
PO VDI FORME B7 D60X32X60	92B7 603260	627601W	184,00



VDI B8

Description	Référence	Code	Prix promo € HT
PO VDI FORME B8 D30X20X40	92B8 302040	628301W	76,00
PO VDI FORME B8 D40X25X44	92B8 402544	628401W	88,00
PO VDI FORME B8 D50X32X55	92B8 503255	628501W	135,00
PO VDI FORME B8 D60X32X60	92B8 603260	628601W	184,00





VDI C1

Description	Référence	Code	Prix promo € HT
PO VDI FORME C1 D30X20X70	92C1 302070	631301W	74,00
PO VDI FORME C1 D40X25X85	92C1 402585	631401W	90,00
PO VDI FORME C1 D50X32X100	92C1 5032100	631501W	121,00
PO VDI FORME C1 D60X32X125	92C1 6032125	631601W	182,00



VDI C2

Description	Référence	Code	Prix promo € HT
PO VDI FORME C2 D30X20X70	92C2 302070	632301W	82,00
PO VDI FORME C2 D40X25X85	92C2 402585	632401W	95,00
PO VDI FORME C2 D50X32X100	92C2 5032100	632501W	125,00
PO VDI FORME C2 D60X32X125	92C2 6032125	632601W	190,00



VDI C3

Description	Référence	Code	Prix promo € HT
PO VDI FORME C3 D30X2070	92C3 302070	633301W	78,00
PO VDI FORME C3 D40X25X85	92C3 402585	633401W	98,00
PO VDI FORME C3 D50X32X100	92C3 5032100	633501W	145,00
PO VDI FORME C3 D60X32X125	92C3 6032125	633601W	190,00



VDI C4

Description	Référence	Code	Prix promo € HT
PO VDI FORME C4 D30X20X70	92C4 302070	634301W	78,00
PO VDI FORME C4 D40X25X85	92C4 402585	634401W	98,00
PO VDI FORME C4 D50X32X100	92C4 5032100	634501W	135,00
PO VDI FORME C4 D60X32X125	92C4 6032125	634601W	190,00



VDI E1

Description	Référence	Code	Prix promo € HT
PO VDI FORME E1 D30X16	92E1 3016	649316W	54,00
PO VDI FORME E1 D30X20	92E1 3020	649320W	54,00
PO VDI FORME E1 D30X25	92E1 3025	649325W	54,00
PO VDI FORME E1 D30X32	92E1 3032	649332W	54,00
PO VDI FORME E1 D30X40	92E1 3040	649340W	55,00
PO VDI FORME E1 D40X16	92E1 4016	649416W	71,00
PO VDI FORME E1 D40X20	92E1 4020	649420W	71,00
PO VDI FORME E1 D40X25	92E1 4025	649425W	71,00
PO VDI FORME E1 D40X32	92E1 4032	649432W	71,00
PO VDI FORME E1 D40X40	92E1 4040	649440W	71,00
PO VDI FORME E1 D40X50	92E1 4050	649450W	71,00
PO VDI FORME E1 D50x16	92E1 5016	649516W	80,00
PO VDI FORME E1 D50x20	92E1 5020	649520W	80,00
PO VDI FORME E1 D50X25	92E1 5025	649525W	80,00
PO VDI FORME E1 D50X32	92E1 5032	649532W	80,00
PO VDI FORME E1 D50X40	92E1 5040	649540W	80,00
PO VDI FORME E1 D50X50	92E1 5050	649550W	90,00
PO VDI FORME E1 D60x16	92E1 6016	649616W	130,00
PO VDI FORME E1 D60x20	92E1 6020	649620W	130,00
PO VDI FORME E1 D60X25	92E1 6025	649625W	130,00
PO VDI FORME E1 D60X32	92E1 6032	649632W	130,00
PO VDI FORME E1 D60X40	92E1 6040	649640W	130,00
PO VDI FORME E1 D60X50	92E1 6050	649650W	140,00



VDI E2

Description	Référence	Code	Prix promo € HT
PO VDI FORME E2 D30X6	92E2 3006	650306W	58,00
PO VDI FORME E2 D30X8	92E2 3008	650308W	58,00
PO VDI FORME E2 D30X10	92E2 3010	650310W	58,00
PO VDI FORME E2 D30X12	92E2 3012	650312W	58,00
PO VDI FORME E2 D30X16	92E2 3016	650316W	58,00
PO VDI FORME E2 D30X20	92E2 3020	650320W	58,00
PO VDI FORME E2 D30X25	92E2 3025	650325W	58,00
PO VDI FORME E2 D30X32	92E2 3032	650332W	58,00
PO VDI FORME E2 D30X40	92E2 3040	650340W	58,00
PO VDI FORME E2 D40X6	92E2 4006	650406W	64,00
PO VDI FORME E2 D40X8	92E2 4008	650408W	64,00
PO VDI FORME E2 D40X10	92E2 4010	650410W	64,00
PO VDI FORME E2 D40X12	92E2 4012	650412W	64,00
PO VDI FORME E2 D40X16	92E2 4016	650416W	64,00
PO VDI FORME E2 D40X20	92E2 4020	650420W	64,00
PO VDI FORME E2 D40X25	92E2 4025	650425W	64,00
PO VDI FORME E2 D40X32	92E2 4032	650432W	65,00
PO VDI FORME E2 D40X40	92E2 4040	650440W	72,00
PO VDI FORME E2 D40X50	92E2 4050	650450W	72,00
PO VDI FORME E2 D50X8	92E2 5008	650508W	85,00
PO VDI FORME E2 D50X10	92E2 5010	650510W	85,00
PO VDI FORME E2 D50X12	92E2 5012	650512W	85,00
PO VDI FORME E2 D50X16	92E2 5016	650516W	85,00
PO VDI FORME E2 D50X20	92E2 5020	650520W	85,00
PO VDI FORME E2 D50X25	92E2 5025	650525W	85,00
PO VDI FORME E2 D50X32	92E2 5032	650532W	85,00
PO VDI FORME E2 D50X40	92E2 5040	650540W	85,00
PO VDI FORME E2 D50X50	92E2 5050	650550W	88,00
PO VDI FORME E2 D60X16	92E2 6016	650616W	120,00
PO VDI FORME E2 D60X20	92E2 6020	650620W	120,00
PO VDI FORME E2 D60X25	92E2 6025	650625W	120,00
PO VDI FORME E2 D60X32	92E2 6032	650632W	120,00
PO VDI FORME E2 D60X40	92E2 6040	650640W	125,00
PO VDI FORME E2 D60X50	92E2 6050	650650W	130,00





VDI E4



VDI F

Description	Référence	Code	Prix promo € HT	Description	Référence	Code	Prix promo € HT
PO VDI FORME E4 D30 PINCE ER16	92E4 3016	683014W	93,00	PO VDI F D30 MK1	92F30 MK1	660301W	64,00
PO VDI FORME E4 D30 PINCE ER25	92E4 3025	683016W	93,00	PO VDI F D30 MK2	92F30 MK2	660302W	64,00
PO VDI FORME E4 D30 PINCE ER32	92E4 3032	683020W	93,00	PO VDI F D30 MK3	92F30 MK3	660303W	64,00
PO VDI FORME E4 D30 PINCE ER40	92E4 3040	683026W	93,00	PO VDI F D40 MK1	92F40 MK1	660401W	70,00
PO VDI FORME E4 D40 PINCE ER25	92E4 4025	684016W	93,00	PO VDI F D40 MK2	92F40 MK2	660402W	70,00
PO VDI FORME E4 D40 PINCE ER32	92E4 4032	684020W	93,00	PO VDI F D40 MK3	92F40 MK3	660403W	70,00
PO VDI FORME E4 D40 PINCE ER40	92E4 4040	684026W	93,00	PO VDI F D40 MK4	92F40 MK4	660404W	78,00
PO VDI FORME E4 D50 PINCE ER25	92E4 5025	685016W	120,00	PO VDI F D50 MK2	92F50 MK2	660502W	89,00
PO VDI FORME E4 D50 PINCE ER32	92E4 5032	685020W	120,00	PO VDI F D50 MK3	92F50 MK3	660503W	89,00
PO VDI FORME E4 D50 PINCE ER40	92E4 5040	685026W	120,00	PO VDI F D50 MK4	92F50 MK4	660504W	99,00
PO VDI FORME E4 D60 PINCE ER32	92E4 6032	686020W	152,00	PO VDI F D50 MK5	92F50 MK5	660505W	135,00
PO VDI FORME E4 D60 PINCE ER40	92E4 6040	686026W	160,00	PO VDI F D60 MK2	92F60 MK2	660602W	128,00
				PO VDI F D60 MK3	92F60 MK3	660603W	128,00
				PO VDI F D60 MK4	92F60 MK4	660604W	136,00
				PO VDI F D60 MK5	92F60 MK5	660605W	145,00



VDI GML



VDI AR

Description	Référence	Code	Prix promo € HT	Description	Référence	Code	Prix promo € HT
MAND TARAUD CHANG RAPIDE	92GML V30GR1	690001W	198,00	PO VDI30 A DTE PORTE LAME 26mm	92AR 3026	640001W	270,00
MAND TARAUD CHANG RAPIDE	92GML V30GR2	690002W	242,00	PO VDI30 A DTE PORTE LAME 32mm	92AR 3032	640002W	308,00
MAND TARAUD CHANG RAPIDE	92GML V40GR1	690003W	210,00	PO VDI40 A DTE PORTE LAME 26mm	92AR 4026	640003W	303,00
MAND TARAUD CHANG RAPIDE	92GML V40GR2	690004W	242,00	PO VDI40 A DTE PORTE LAME 32mm	92AR 4032	640004W	303,00
MAND TARAUD CHANG RAPIDE	92GML V40GR3	690005W	319,00	PO VDI50 A DTE PORTE LAME 26mm	92AR 5026	640005W	319,00
MAND TARAUD CHANG RAPIDE	92GML V50GR3	690006W	330,00	PO VDI50 A DTE PORTE LAME 32mm	92AR 5032	640006W	319,00
MAND TARAUD CHANG RAPIDE	92GML V50GR1	690008W	220,00	PO VDI60 A DTE PORTE LAME 32mm	92AR 6032	640007W	550,00
MAND TARAUD CHANG RAPIDE	92GML V50GR2	690009W	253,00				



VDI ARU



VDI AL

Description	Référence	Code	Prix promo € HT	Description	Référence	Code	Prix promo € HT
PO VDI30 A DTE PORTE LAME 26mm	92ARU 3026	640010W	269,00	PO VDI30 A GCHE PORTE LAME 26mm	92AL 3026	640020W	270,00
PO VDI30 A DTE PORTE LAME 32mm	92ARU 3032	640011W	313,00	PO VDI30 A GCHE PORTE LAME 32mm	92AL 3032	640021W	308,00
PO VDI40 A DTE PORTE LAME 26mm	92ARU 4026	640012W	297,00	PO VDI40 A GCHE PORTE LAME 26mm	92AL 4026	640022W	303,00
PO VDI40 A DTE PORTE LAME 32mm	92ARU 4032	640013W	313,00	PO VDI40 A GCHE PORTE LAME 32mm	92AL 4032	640023W	303,00
PO VDI50 A DTE PORTE LAME 26mm	92ARU 5026	640014W	324,00				
PO VDI50 A DTE PORTE LAME 32mm	92ARU 5032	640015W	341,00				



VDI SG

Description	Référence	Code	Prix promo € HT
TIRE BARRE VDI30 CAP 6 110	92SG 30	641001	670,00
TIRE BARRE VDI40 CAP 6 110	92SG 40	641002	740,00
TIRE BARRE VDI50 CAP 6 110	92SG 50	641003	950,00





TYPE TOLÉRANCE				GO / NOGO 6H		GO 6G		NOGO 6G	
M	MF	P	Index	S3 302161		Y3 412162		Y3 42211862	
				Code	Prix promo	Code	Prix promo	Code	Prix promo
M	2	0,4	0020	-	57,00	555090	57,00	555151	79,00
M	2,5	0,45	0025	-	67,00	555091	79,00	555152	79,00
M	3	0,5	0030	555040	47,00	555093	54,00	555154	60,00
M	3,5	0,6	0035	555041	55,00	555094	64,00	555155	60,00
M	4	0,7	0040	045062	47,00	555095	54,00	555156	60,00
M	5	0,8	0050	045063	47,00	555097	54,00	555158	60,00
M	6	1	0060	045064	47,00	555098	54,00	555159	60,00
M	7	1	0070	555046	55,00	555099	60,00	555160	60,00
M	8	1,25	0080	045065	47,00	555100	54,00	555161	60,00
M	8	1	0083	555048	55,00	555101	69,00	555162	60,00
M	9	1,25	0090						
M	10	1,5	0100	045066	51,00	555103	59,00	555164	70,00
M	10	1	0103	555051	60,00	555104	75,00	555165	67,00
M	10	1,25	0104	555052	60,00	555105	75,00	555166	67,00
M	12	1,75	0120	045067	51,00	555106	59,00	555167	70,00
M	12	1,5	0125	555054	60,00	555107	75,00	555168	67,00
M	14	2	0140	555055	57,00	555108	65,00	555169	72,00
M	14	1,5	0145	555056	64,00	555109	82,00	555170	70,00
M	16	2	0160	045068	57,00	555110	65,00	555171	72,00
M	16	1,5	0165	555058	64,00	555111	82,00	555172	70,00
M	18	2,5	01800	555059	65,00	555112	89,00	555173	105,00
M	18	1,5	0185	555060	76,00	555113	110,00	555174	90,00
M	20	2,5	0200	555061	81,00	555114	89,00	555175	105,00
M	20	1,5	0205	555062	99,00	555115	110,00	555176	90,00
M	22	2,5	0220	555063	95,00	555116	105,00	555177	105,00
M	22	1,5	0225	555064	76,00	555117	90,00	555178	90,00
M	24	3	0240	555065	95,00	555118	105,00	555179	105,00
M	24	1,5	0245	555066	76,00	555119	90,00	555180	90,00
M	25	1,5	0255	-	95,00	555120	105,00	-	105,00
M	27	3	0270	555067	113,00	555121	127,00	555181	127,00
M	30	3,5	0300	555068	172,00	555123	193,00	555183	193,00
M	30	1,5	0305	-	113,00	555124	127,00	-	127,00
M	33	3,5	0330	555069	171,00	555125	189,00	555184	189,00
M	36	4	0360	555070	171,00	555126	189,00	555185	189,00
M	39	4	0390	555071	171,00	555127	189,00	555186	189,00
M	42	4,5	0420	555072	200,00	555129	215,00	555188	215,00
M	45	4,5	0450	555073	200,00	555130	215,00	555189	215,00
M	48	5	0480	555074	227,00	555131	249,00	555190	249,00
M	52	5	0520			555133	149,00	555191	149,00



TYPE TOLÉRANCE			GO / NOGO		GO A		NOGO A	
G	1"/P	Index	S3 302180		Y3 412180		Y3 422180	
			Code	Prix	Code	Prix	Code	Prix
G 1/8"	28	3123	555039	90,00	555143	108,00		52,57
G 1/4"	19	3127	555038	90,00	555142	108,00		62,51
G 3/8"	19	3129	555076	90,00	555137	108,00	555193	108,00
G 1/2"	14	3131	555077	90,00	555138	108,00	555194	108,00
G 5/8"	14	3133		-	555139	-	555195	-
G 3/4"	14	3135	555078	102,00	555140	127,00	555196	127,00



TYPE TOLÉRANCE				GO/NOGO H7			
Ø nom.	Index	S3 100111		Ø nom.	Index	S3 100111	
		Code	Prix			Code	Prix
3	0030	555001	32,00	26	0260	555015	39,00
4	0040	555002	32,00	28	0280	555016	39,00
5	0050	555003	35,00	30	0300	555017	42,00
6	0060	555004	35,00	32	0320	555018	42,00
8	0080	555005	35,00	34	0340	555020	46,00
10	0100	555006	35,00	35	0350	555021	46,00
12	0120	555007	35,00	36	0360	555022	46,00
14	0140	555008	35,00	37	0370	555023	52,00
16	0160	555009	35,00	38	0380	555024	52,00
18	0180	555010	35,00	40	0400	555025	52,00
20	0200	555011	36,00	42	0420	555026	64,00
22	0220	555012	36,00	45	0450	555027	79,00
24	0240	555013	36,00	47	0470	555028	84,00
25	0250	555014	39,00	50	0500	555029	90,00

Franco de port départ agences - 150 €

Forfait expédition usine - 20 €

Les articles lourds sont indiqués par un logo poids. 
 Pour ces articles, **des frais de transport supplémentaires sont appliqués.**

Retrouvez également :



Outils de bridage

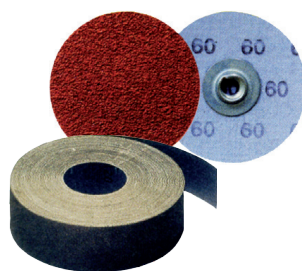

Abrasifs



Fraises Slotworx HP M



Rectification



Machines traditionnelles



Fraises Akko

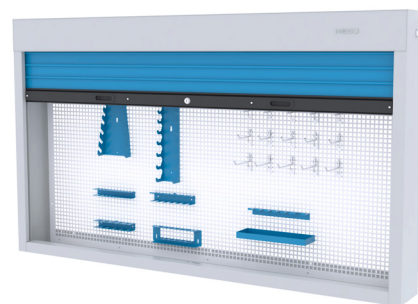

Meubles d'atelier

Rendez-vous
sur notre site internet !

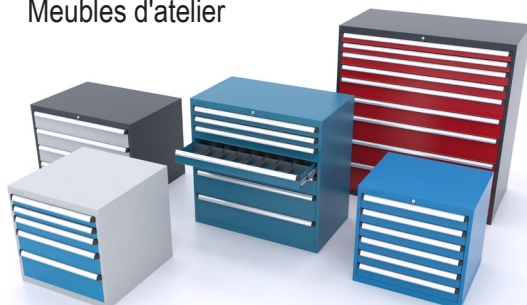



Techmo - Orléans

ECOPARK Orléans N°28
1695 rue de la Grand Cour
45760 MARIGNY-LES-USAGES
02 38 61 48 10
commercial.techmo@techmo.fr



Techmo - Toulouse

18 chemin de la violette
31240 L'UNION
05 61 61 34 35
magasin.toulouse@techmo.fr



Satech - Le Mans

ACTIPARC N°6
150 route du parc
72700 SPAY
02 43 40 05 05
magasin@satech.fr



Techmo Satech

techmo.fr | satech.fr

En 2021, Techmo a fêté ses 40 ans

**Cette année, c'est au tour de Satech
de souffler ses 40 bougies.**

Rendez-vous sur notre page Likendln
pour suivre les festivités...

PRIX PROMOTIONNELS NET HT

OFFRE VALABLE

DANS LA LIMITE

DES STOCKS DISPONIBLES

31-12-2025*

* TECHMO SATECH NE PEUT GARANTIR LES PRIX SUR L'ANNÉE 2025

Nous nous donnons la possibilité de modifier les prix promotionnels en fonction des éventuels changements de prix de nos partenaires.