

# ACTIONS PROMOTIONNELLES

PRIX PROMOTIONNELS NET HT  
OFFRE VALABLE JUSQU'AU 30 JUIN 2018



## FRAISES

|                                |    |
|--------------------------------|----|
| FRAISES CARBURES ET INOX   HPC | 2  |
| FRAISES CARBURES   FIGHTMAX    | 8  |
| ECONOMY-LINE                   | 9  |
| SÉRIE COURTE                   | 10 |
| SÉRIE COURTE DEUX TAILLES      | 11 |
| RN540 CINQ DENTS               | 12 |
| HSS CO5                        | 13 |
| WX6 505 REVÊTUES               | 13 |
| FRAISES À PLAQUETTES   HFMM    | 14 |
| RM3 - ERM3                     | 15 |
| FRAISES CARBURES À FILETER     | 16 |

## FORETS

|                                     |    |
|-------------------------------------|----|
| FORETS HELICOIDALX CARBURE MONOBLOC | 17 |
| FORETS CYLINDRIQUES COURTS          | 18 |
| FORETS À POINTER                    | 20 |
| FORETS À PLAQUETTES                 | 20 |

## TARAUDS

|                                   |    |
|-----------------------------------|----|
| TARAUDS MACHINE HAUTE PERFORMANCE | 21 |
| TARAUDS À REFOULER                | 23 |
| LUBRIFIANTS POUR TARAUDAGE        | 23 |

## BARRES ALÉSAGES

|                          |    |
|--------------------------|----|
| BARRES CARBURES MONOBLOC | 24 |
|--------------------------|----|

## PORTE-OUTILS

|                                       |    |
|---------------------------------------|----|
| PORTE-OUTILS   ECO TURN MULTIFONCTION | 26 |
| PORTE-OUTILS   EXTÉRIEUR              | 26 |

## MEULEUSES

|           |    |
|-----------|----|
| MEULEUSES | 27 |
|-----------|----|

## ACCESSOIRES

|                                       |    |
|---------------------------------------|----|
| ACCESSOIRES   KIT DINAPLUS            | 29 |
| ACCESSOIRES   ROULEAU ATELIER ABRASIF | 30 |

# FRAISES CARBURES ET INOX | HPC

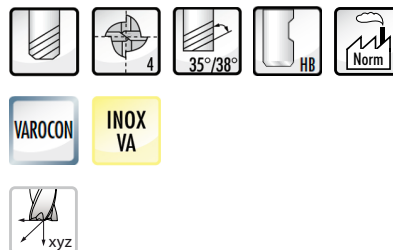
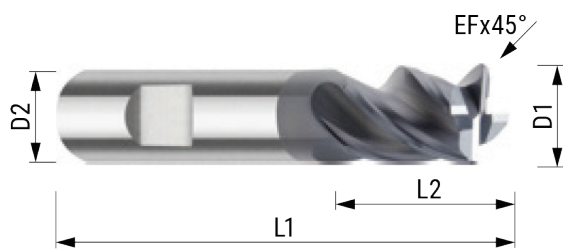

## Articles 1.388...

| D1    | D2 H6 | L2 | L1 | EF   | Z | Articles     | Code   | Prix tarif<br>€ net HT | Prix promo<br>€ net HT |
|-------|-------|----|----|------|---|--------------|--------|------------------------|------------------------|
| 3,00  | 6,00  | 6  | 54 | 0,10 | 4 | 1.388.030.10 | 366058 | <del>14,94</del>       | 12,88                  |
| 4,00  | 6,00  | 8  | 54 | 0,13 | 4 | 1.388.040.10 | 366059 | <del>14,94</del>       | 12,88                  |
| 5,00  | 6,00  | 9  | 54 | 0,18 | 4 | 1.388.050.10 | 366060 | <del>14,94</del>       | 12,88                  |
| 6,00  | 6,00  | 10 | 54 | 0,20 | 4 | 1.388.060.10 | 366052 | <del>14,94</del>       | 12,88                  |
| 8,00  | 8,00  | 12 | 58 | 0,20 | 4 | 1.388.080.10 | 366053 | <del>18,54</del>       | 15,98                  |
| 10,00 | 10,00 | 14 | 66 | 0,20 | 4 | 1.388.100.10 | 366054 | <del>25,96</del>       | 22,38                  |
| 12,00 | 12,00 | 16 | 73 | 0,30 | 4 | 1.388.120.10 | 366055 | <del>37,06</del>       | 31,97                  |
| 16,00 | 16,00 | 22 | 82 | 0,30 | 4 | 1.388.160.10 | 366056 | <del>63,96</del>       | 55,14                  |
| 20,00 | 20,00 | 26 | 92 | 0,40 | 4 | 1.388.200.10 | 366057 | <del>96,41</del>       | 83,12                  |

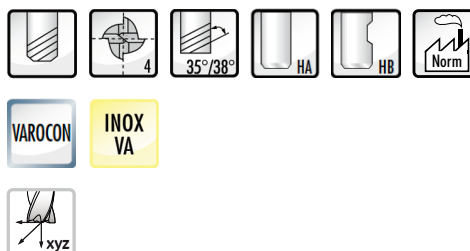
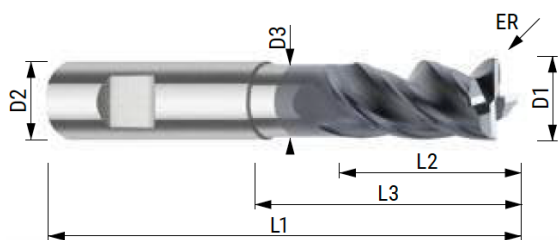

## Articles 1.390 ...

| D1    | D2    | L2 | L1  | D3    | L3 | EF  | Z | Articles      | HA  | HB  | Code   |        | Prix €<br>net HT |
|-------|-------|----|-----|-------|----|-----|---|---------------|-----|-----|--------|--------|------------------|
|       |       |    |     |       |    |     |   |               |     |     | HA     | HB     |                  |
| 3,00  | 6,00  | 8  | 57  | 2,75  | 18 | 0,2 | 4 | 1.390.030 ... | .00 | .10 | 366330 | 366901 | 18,45            |
| 4,00  | 6,00  | 11 | 57  | 3,50  | 21 | 0,2 | 4 | 1.390.040 ... | .00 | .10 | 366331 | 366902 | 18,45            |
| 5,00  | 6,00  | 13 | 57  | 4,50  | 21 | 0,2 | 4 | 1.390.050 ... | .00 | .10 | 366332 | 366903 | 18,45            |
| 6,00  | 6,00  | 13 | 57  | 5,50  | 21 | 0,2 | 4 | 1.390.060 ... | .00 | .10 | 366333 | 366090 | 18,45            |
| 8,00  | 8,00  | 19 | 63  | 7,50  | 27 | 0,2 | 4 | 1.390.080 ... | .00 | .10 | 366334 | 366091 | 25,13            |
| 10,00 | 10,00 | 22 | 72  | 9,50  | 32 | 0,2 | 4 | 1.390.100 ... | .00 | .10 | 366335 | 366092 | 34,51            |
| 12,00 | 12,00 | 26 | 83  | 11,50 | 38 | 0,2 | 4 | 1.390.120 ... | .00 | .10 | 366336 | 366093 | 47,38            |
| 16,00 | 16,00 | 32 | 92  | 15,50 | 44 | 0,2 | 4 | 1.390.160 ... | .00 | .10 | 366337 | 366094 | 72,62            |
| 20,00 | 20,00 | 38 | 104 | 19,50 | 54 | 0,2 | 4 | 1.390.200 ... | .00 | .10 | 366338 | 366095 | 107,64           |

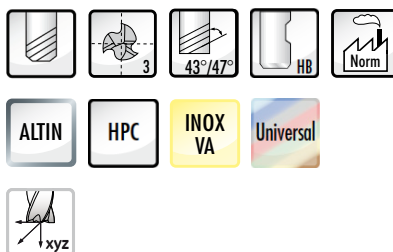
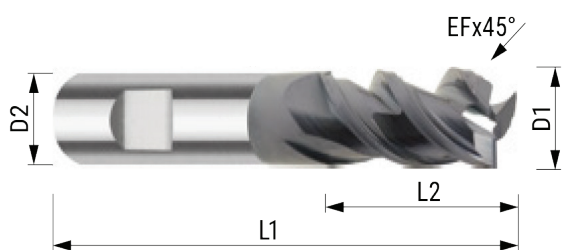

### Articles 1.391 ...

| D1    | D2 H6 | L2 | L1  | EF   | Z | Articles     | Code   | Prix tarif<br>€ net HT | Prix promo<br>€ net HT |
|-------|-------|----|-----|------|---|--------------|--------|------------------------|------------------------|
| 3,00  | 6,00  | 8  | 57  | 0,05 | 3 | 1.391.030.10 | 366134 | <del>18,54</del>       | 15,98                  |
| 4,00  | 6,00  | 11 | 57  | 0,05 | 3 | 1.391.040.10 | 366135 | <del>18,54</del>       | 15,98                  |
| 5,00  | 6,00  | 13 | 57  | 0,08 | 3 | 1.391.050.10 | 366136 | <del>18,54</del>       | 15,98                  |
| 6,00  | 6,00  | 13 | 57  | 0,08 | 3 | 1.391.060.10 | 366137 | <del>18,54</del>       | 15,98                  |
| 7,00  | 8,00  | 16 | 63  | 0,08 | 3 | 1.391.070.10 | 366138 | <del>25,13</del>       | 21,66                  |
| 8,00  | 8,00  | 19 | 63  | 0,10 | 3 | 1.391.080.10 | 366139 | <del>25,13</del>       | 21,66                  |
| 9,00  | 10,00 | 19 | 72  | 0,10 | 3 | 1.391.090.10 | 366140 | <del>35,02</del>       | 30,19                  |
| 10,00 | 10,00 | 22 | 72  | 0,10 | 3 | 1.391.100.10 | 366141 | <del>35,02</del>       | 30,19                  |
| 12,00 | 12,00 | 26 | 83  | 0,15 | 3 | 1.391.120.10 | 366142 | <del>49,44</del>       | 42,62                  |
| 16,00 | 16,00 | 32 | 92  | 0,20 | 3 | 1.391.160.10 | 366143 | <del>80,34</del>       | 69,26                  |
| 20,00 | 20,00 | 38 | 104 | 0,20 | 3 | 1.391.200.10 | 366144 | <del>128,75</del>      | 110,99                 |

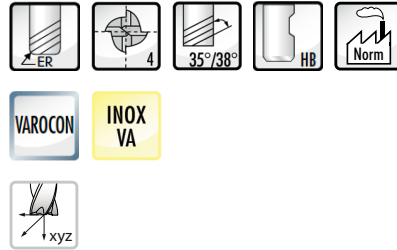
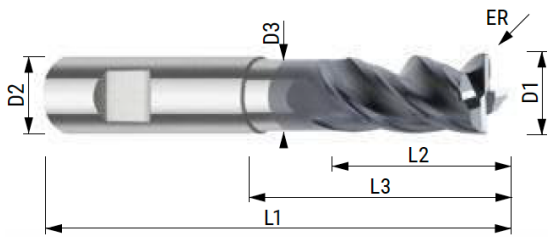

### Articles 1.393 ...

| D1    | D2    | L2 | L1  | D3   | L3 | EF  | Z | Articles         | Code   | Prix € net HT |
|-------|-------|----|-----|------|----|-----|---|------------------|--------|---------------|
| 8,00  | 8,00  | 19 | 63  | 7,5  | 27 | 0,5 | 4 | 1.393.081.10 ... | 366905 | 26,78         |
| 8,00  | 8,00  | 19 | 63  | 7,5  | 27 | 1,0 | 4 | 1.393.082.10 ... | 366906 | 26,78         |
| 8,00  | 8,00  | 19 | 63  | 7,5  | 27 | 1,5 | 4 | 1.393.083.10 ... | 366907 | 26,78         |
| 8,00  | 8,00  | 19 | 63  | 7,5  | 27 | 2,0 | 4 | 1.393.084.10 ... | 366908 | 26,78         |
| 8,00  | 8,00  | 19 | 63  | 7,5  | 27 | 2,5 | 4 | 1.393.085.10 ... | 366909 | 26,78         |
| 10,00 | 10,00 | 22 | 72  | 9,5  | 32 | 0,5 | 4 | 1.393.101.10 ... | 366911 | 36,57         |
| 10,00 | 10,00 | 22 | 72  | 9,5  | 32 | 1,0 | 4 | 1.393.102.10 ... | 366912 | 36,57         |
| 10,00 | 10,00 | 22 | 72  | 9,5  | 32 | 1,5 | 4 | 1.393.103.10 ... | 366913 | 36,57         |
| 10,00 | 10,00 | 22 | 72  | 9,5  | 32 | 2,0 | 4 | 1.393.104.10 ... | 366914 | 36,57         |
| 10,00 | 10,00 | 22 | 72  | 9,5  | 32 | 2,5 | 4 | 1.393.105.10 ... | 366915 | 36,57         |
| 10,00 | 10,00 | 22 | 72  | 9,5  | 32 | 3,0 | 4 | 1.393.106.10 ... | 366916 | 36,57         |
| 10,00 | 10,00 | 22 | 72  | 9,5  | 32 | 4,0 | 4 | 1.393.107.10 ... | 366917 | 36,57         |
| 12,00 | 12,00 | 26 | 83  | 11,5 | 38 | 0,5 | 4 | 1.393.121.10 ... | 366919 | 49,96         |
| 12,00 | 12,00 | 26 | 83  | 11,5 | 38 | 1,0 | 4 | 1.393.122.10 ... | 366920 | 49,96         |
| 12,00 | 12,00 | 26 | 83  | 11,5 | 38 | 1,5 | 4 | 1.393.123.10 ... | 366921 | 49,96         |
| 12,00 | 12,00 | 26 | 83  | 11,5 | 38 | 2,0 | 4 | 1.393.124.10 ... | 366922 | 49,96         |
| 12,00 | 12,00 | 26 | 83  | 11,5 | 38 | 2,5 | 4 | 1.393.125.10 ... | 366923 | 49,96         |
| 12,00 | 12,00 | 26 | 83  | 11,5 | 38 | 3,0 | 4 | 1.393.126.10 ... | 366924 | 49,96         |
| 12,00 | 12,00 | 26 | 83  | 11,5 | 38 | 4,0 | 4 | 1.393.127.10 ... | 366925 | 49,96         |
| 16,00 | 16,00 | 32 | 92  | 15,5 | 44 | 0,5 | 4 | 1.393.161.10 ... | 366927 | 76,22         |
| 16,00 | 16,00 | 32 | 92  | 15,5 | 44 | 1,0 | 4 | 1.393.162.10 ... | 366928 | 76,22         |
| 16,00 | 16,00 | 32 | 92  | 15,5 | 44 | 1,5 | 4 | 1.393.163.10 ... | 366929 | 76,22         |
| 16,00 | 16,00 | 32 | 92  | 15,5 | 44 | 2,0 | 4 | 1.393.164.10 ... | 366930 | 76,22         |
| 16,00 | 16,00 | 32 | 92  | 15,5 | 44 | 2,5 | 4 | 1.393.164.10 ... | 366931 | 76,22         |
| 16,00 | 16,00 | 32 | 92  | 15,5 | 44 | 3,0 | 4 | 1.393.166.10 ... | 366932 | 76,22         |
| 16,00 | 16,00 | 32 | 92  | 15,5 | 44 | 4,0 | 4 | 1.393.167.10 ... | 366933 | 76,22         |
| 20,00 | 20,00 | 38 | 104 | 19,5 | 54 | 0,5 | 4 | 1.393.201.10 ... | 366935 | 112,27        |
| 20,00 | 20,00 | 38 | 104 | 19,5 | 54 | 1,0 | 4 | 1.393.202.10 ... | 366936 | 112,27        |
| 20,00 | 20,00 | 38 | 104 | 19,5 | 54 | 1,5 | 4 | 1.393.203.10 ... | 366937 | 112,27        |
| 20,00 | 20,00 | 38 | 104 | 19,5 | 54 | 2,0 | 4 | 1.393.204.10 ... | 366938 | 112,27        |
| 20,00 | 20,00 | 38 | 104 | 19,5 | 54 | 2,5 | 4 | 1.393.205.10 ... | 366939 | 112,27        |
| 20,00 | 20,00 | 38 | 104 | 19,5 | 54 | 3,0 | 4 | 1.393.206.10 ... | 366940 | 112,27        |
| 20,00 | 20,00 | 38 | 104 | 19,5 | 54 | 4,0 | 4 | 1.393.207.10 ... | 366941 | 112,27        |

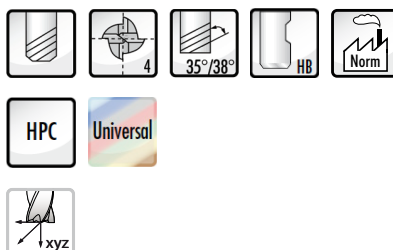
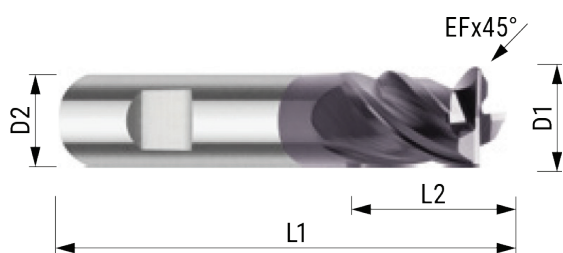

### Articles 1.741...

| D1    | D2 H6 | L2 | L1 | EF   | Z | Articles     | Code   | Prix tarif<br>€ net HT | Prix promo<br>€ net HT |
|-------|-------|----|----|------|---|--------------|--------|------------------------|------------------------|
| 3,00  | 6,00  | 6  | 54 | 0,10 | 4 | 1.741.030.10 | 366243 | <del>11,95</del>       | 10,30                  |
| 4,00  | 6,00  | 8  | 54 | 0,13 | 4 | 1.741.040.10 | 366244 | <del>11,95</del>       | 10,30                  |
| 5,00  | 6,00  | 9  | 54 | 0,18 | 4 | 1.741.050.10 | 366245 | <del>11,95</del>       | 10,30                  |
| 6,00  | 6,00  | 10 | 54 | 0,20 | 4 | 1.741.060.10 | 366246 | <del>11,95</del>       | 10,30                  |
| 8,00  | 8,00  | 12 | 58 | 0,20 | 4 | 1.741.080.10 | 366247 | <del>15,97</del>       | 13,77                  |
| 10,00 | 10,00 | 14 | 66 | 0,20 | 4 | 1.741.100.10 | 366248 | <del>21,22</del>       | 18,29                  |
| 12,00 | 12,00 | 16 | 73 | 0,30 | 4 | 1.741.120.10 | 366249 | <del>29,36</del>       | 25,31                  |
| 16,00 | 16,00 | 22 | 82 | 0,30 | 4 | 1.741.160.10 | 366250 | <del>50,37</del>       | 43,42                  |
| 20,00 | 20,00 | 26 | 92 | 0,40 | 4 | 1.741.200.10 | 366251 | <del>74,06</del>       | 63,84                  |

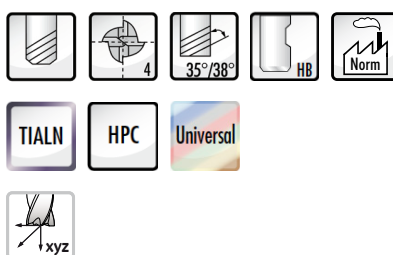
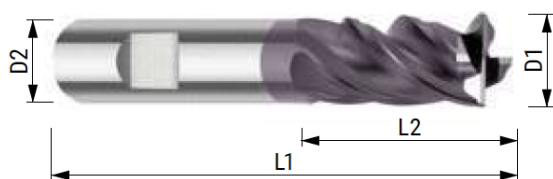

### Articles 1.742 ...

| D1    | D2 H6 | L2 | L1  | EF  | Z | Articles     | Code   | Prix tarif<br>€ net HT | Prix promo<br>€ net HT |
|-------|-------|----|-----|-----|---|--------------|--------|------------------------|------------------------|
| 6,00  | 6,00  | 13 | 57  | 0,2 | 4 | 1.742.060.10 | 366255 | <del>12,35</del>       | 8,82                   |
| 8,00  | 8,00  | 19 | 63  | 0,2 | 4 | 1.742.080.10 | 366256 | <del>18,03</del>       | 12,88                  |
| 10,00 | 10,00 | 22 | 72  | 0,2 | 4 | 1.742.100.10 | 366257 | <del>23,59</del>       | 16,85                  |
| 12,00 | 12,00 | 26 | 83  | 0,2 | 4 | 1.742.120.10 | 366258 | <del>33,99</del>       | 24,48                  |
| 16,00 | 16,00 | 32 | 92  | 0,2 | 4 | 1.742.160.10 | 366259 | <del>53,56</del>       | 38,26                  |
| 20,00 | 20,00 | 38 | 104 | 0,2 | 4 | 1.742.200.10 | 366260 | <del>81,37</del>       | 58,12                  |

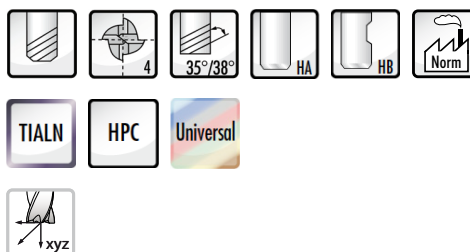
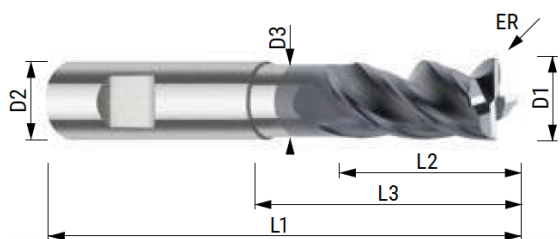

### Articles 1.743 ...

| D1    | D2    | L2 | L1  | D3    | L3 | EF   | Z | Articles      | HA  | HB  | Code   |        | Prix tarif<br>€ net HT | Prix promo<br>€ net HT |
|-------|-------|----|-----|-------|----|------|---|---------------|-----|-----|--------|--------|------------------------|------------------------|
|       |       |    |     |       |    |      |   |               |     |     | HA     | HB     |                        |                        |
| 3,00  | 6,00  | 8  | 57  | 2,80  | 18 | 0,13 | 4 | 1.743.030 ... | .00 | .10 | 366280 | 366261 | <del>16,48</del>       | 11,77                  |
| 4,00  | 6,00  | 11 | 57  | 3,60  | 21 | 0,13 | 4 | 1.743.040 ... | .00 | .10 | 366281 | 366262 | <del>16,48</del>       | 11,77                  |
| 5,00  | 6,00  | 13 | 57  | 4,60  | 21 | 0,13 | 4 | 1.743.050 ... | .00 | .10 | 366282 | 366263 | <del>16,48</del>       | 11,77                  |
| 6,00  | 6,00  | 13 | 57  | 5,50  | 21 | 0,13 | 4 | 1.743.060 ... | .00 | .10 | 366283 | 366264 | <del>16,48</del>       | 11,77                  |
| 8,00  | 8,00  | 19 | 63  | 7,50  | 27 | 0,13 | 4 | 1.743.080 ... | .00 | .10 | 366284 | 366265 | <del>13,18</del>       | 16,56                  |
| 10,00 | 10,00 | 22 | 72  | 9,50  | 32 | 0,13 | 4 | 1.743.100 ... | .00 | .10 | 366285 | 366266 | <del>28,84</del>       | 20,60                  |
| 12,00 | 12,00 | 26 | 83  | 11,50 | 38 | 0,13 | 4 | 1.743.120 ... | .00 | .10 | 366286 | 366267 | <del>40,17</del>       | 28,70                  |
| 16,00 | 16,00 | 32 | 92  | 15,50 | 44 | 0,13 | 4 | 1.743.160 ... | .00 | .10 | 366287 | 366268 | <del>61,70</del>       | 44,07                  |
| 20,00 | 20,00 | 38 | 104 | 19,50 | 54 | 0,13 | 4 | 1.743.200 ... | .00 | .10 | 366288 | 366269 | <del>91,67</del>       | 65,49                  |

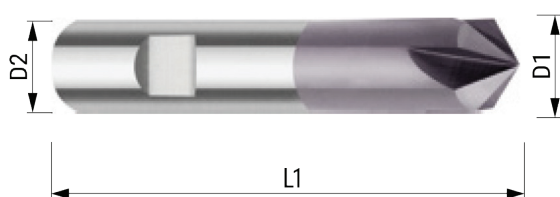

### Articles 1.795 ...

| D1    | D2 H6 | L1  | Z | Articles     | Code   | Prix tarif<br>€ net HT | Prix promo<br>€ net HT |
|-------|-------|-----|---|--------------|--------|------------------------|------------------------|
| 4,00  | 4,00  | 54  | 4 | 1.795.040.10 | 366176 | <del>14,32</del>       | 12,34                  |
| 6,00  | 6,00  | 57  | 4 | 1.795.060.10 | 366177 | <del>17,61</del>       | 15,17                  |
| 8,00  | 8,00  | 63  | 4 | 1.795.080.10 | 366178 | <del>23,07</del>       | 19,90                  |
| 10,00 | 10,00 | 72  | 4 | 1.795.100.10 | 366179 | <del>26,47</del>       | 22,81                  |
| 12,00 | 12,00 | 83  | 4 | 1.795.120.10 | 366180 | <del>30,45</del>       | 34,02                  |
| 16,00 | 16,00 | 92  | 4 | 1.795.160.10 | 366181 | <del>67,26</del>       | 57,98                  |
| 20,00 | 20,00 | 104 | 4 | 1.795.200.10 | 366182 | <del>101,97</del>      | 87,90                  |

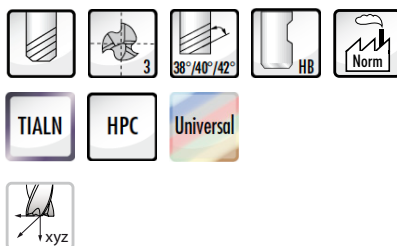
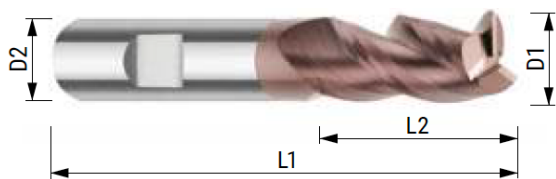

### Articles 1.929 ...

| D1    | D2    | L2 | L1  | EF   | Z | Articles         | Code   | Prix tarif<br>€ net HT | Prix promo<br>€ net HT |
|-------|-------|----|-----|------|---|------------------|--------|------------------------|------------------------|
| 3,00  | 6,00  | 8  | 57  | 0,10 | 3 | 1.929.030.10 ... | 366185 | <del>12,88</del>       | 10,73                  |
| 4,00  | 6,00  | 11 | 57  | 0,10 | 3 | 1.929.040.10 ... | 366186 | <del>12,36</del>       | 10,73                  |
| 5,00  | 6,00  | 13 | 57  | 0,15 | 3 | 1.929.050.10 ... | 366187 | <del>13,49</del>       | 11,25                  |
| 6,00  | 6,00  | 13 | 57  | 0,20 | 3 | 1.929.060.10 ... | 366188 | <del>14,06</del>       | 11,72                  |
| 8,00  | 8,00  | 19 | 63  | 0,20 | 3 | 1.929.080.10 ... | 366189 | <del>19,06</del>       | 15,88                  |
| 10,00 | 10,00 | 22 | 72  | 0,20 | 3 | 1.929.100.10 ... | 366190 | <del>25,03</del>       | 20,87                  |
| 12,00 | 12,00 | 26 | 83  | 0,30 | 3 | 1.929.120.10 ... | 366191 | <del>34,98</del>       | 29,15                  |
| 16,00 | 16,00 | 32 | 92  | 0,30 | 3 | 1.929.160.10 ... | 366192 | <del>55,04</del>       | 45,87                  |
| 20,00 | 20,00 | 38 | 104 | 0,40 | 3 | 1.929.200.10 ... | 366193 | <del>85,08</del>       | 70,90                  |

# FRAISES CARBURES | FIGHTMAX

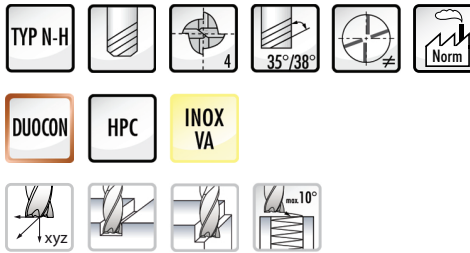
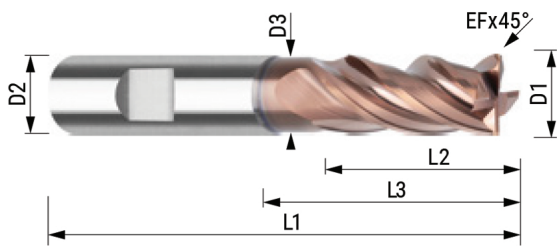

## Articles 288 ...

| D1    | D2    | L2 | L1  | D3    | L3 | EF   | Z | Articles    | HA  | HB  | Code   |        | Prix tarif<br>€ net HT | Prix promo<br>€ net HT |
|-------|-------|----|-----|-------|----|------|---|-------------|-----|-----|--------|--------|------------------------|------------------------|
|       |       |    |     |       |    |      |   |             |     |     | HA     | HB     |                        |                        |
| 6,00  | 6,00  | 13 | 57  | 5,50  | 21 | 0,13 | 4 | 288.060 ... | .00 | .10 | 364349 | 363757 | <del>37,50</del>       | 25,86                  |
| 8,00  | 8,00  | 19 | 63  | 7,50  | 27 | 0,15 | 4 | 288.080 ... | .00 | .10 | 364350 | 363758 | <del>49,90</del>       | 34,11                  |
| 10,00 | 10,00 | 22 | 72  | 9,50  | 32 | 0,20 | 4 | 288.100 ... | .00 | .10 | 364351 | 363759 | <del>69,90</del>       | 48,21                  |
| 12,00 | 12,00 | 26 | 83  | 11,50 | 38 | 0,52 | 4 | 288.120 ... | .00 | .10 | 364352 | 363760 | <del>91,90</del>       | 63,38                  |
| 16,00 | 16,00 | 32 | 92  | 15,50 | 44 | 0,35 | 4 | 288.160 ... | .00 | .10 | 364353 | 363761 | <del>162,50</del>      | 112,07                 |
| 20,00 | 20,00 | 38 | 104 | 19,20 | 54 | 0,40 | 4 | 288.200 ... | .00 | .10 | 364354 | 363762 | <del>221,50</del>      | 152,76                 |

# FRAISES CARBURES | ECONOMY-LINE

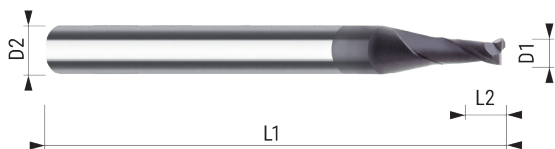

## Articles 913.2 ...

| D1 H10 | L1 | L  | D2 H6 | Z | Articles   | Code   | Prix € net HT |
|--------|----|----|-------|---|------------|--------|---------------|
| 0,5    | 1  | 38 | 3,00  | 2 | 913.205.00 | 366225 | 8,29          |
| 0,6    | 1  | 38 | 3,00  | 2 | 913.206.00 | 366226 | 8,29          |
| 0,7    | 1  | 38 | 3,00  | 2 | 913.207.00 | 366227 | 8,29          |
| 0,8    | 1  | 38 | 3,00  | 2 | 913.208.00 | 366228 | 8,29          |
| 0,9    | 1  | 38 | 3,00  | 2 | 913.209.00 | 366229 | 8,29          |
| 1,0    | 2  | 38 | 3,00  | 2 | 913.210.00 | 366230 | 7,69          |
| 1,1    | 2  | 38 | 3,00  | 2 | 913.211.00 | 366231 | 7,69          |
| 1,2    | 2  | 38 | 3,00  | 2 | 913.212.00 | 366232 | 7,69          |
| 1,4    | 2  | 38 | 3,00  | 2 | 913.214.00 | 366233 | 7,69          |
| 1,5    | 2  | 38 | 3,00  | 2 | 913.215.00 | 366234 | 7,69          |
| 1,6    | 2  | 38 | 3,00  | 2 | 913.216.00 | 366235 | 7,11          |
| 1,7    | 3  | 38 | 3,00  | 2 | 913.217.00 | 366236 | 7,11          |
| 1,8    | 3  | 38 | 3,00  | 2 | 913.218.00 | 366237 | 7,11          |
| 1,9    | 3  | 38 | 3,00  | 2 | 913.219.00 | 366238 | 7,11          |
| 2,0    | 3  | 38 | 3,00  | 2 | 913.220.00 | 366239 | 7,11          |
| 2,5    | 3  | 38 | 3,00  | 2 | 913.225.00 | 366240 | 7,11          |
| 3,0    | 3  | 38 | 3,00  | 2 | 913.230.00 | 366241 | 7,11          |

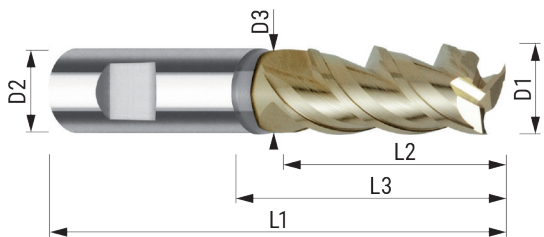

### Articles 945 ...

| D1    | D2    | L2 | L1  | D3    | L3 | Z | Articles   | Code   | Prix tarif<br>€ net HT | Prix promo<br>€ net HT |
|-------|-------|----|-----|-------|----|---|------------|--------|------------------------|------------------------|
| 3,00  | 6,00  | 12 | 38  | -     | -  | 3 | 945.030.19 | 366982 | <del>18,36</del>       | 16,46                  |
| 4,00  | 6,00  | 12 | 54  | 3,80  | 18 | 3 | 945.040.19 | 366983 | <del>18,36</del>       | 16,46                  |
| 5,00  | 6,00  | 15 | 54  | 4,80  | 18 | 3 | 945.050.19 | 366984 | <del>18,36</del>       | 16,46                  |
| 6,00  | 6,00  | 16 | 57  | 5,80  | 21 | 3 | 945.060.19 | 366985 | <del>19,99</del>       | 17,92                  |
| 8,00  | 8,00  | 22 | 63  | 7,80  | 28 | 3 | 945.080.19 | 366986 | <del>26,68</del>       | 26,61                  |
| 10,00 | 10,00 | 25 | 72  | 9,70  | 33 | 3 | 945.100.19 | 366987 | <del>39,07</del>       | 35,03                  |
| 12,00 | 12,00 | 28 | 83  | 11,70 | 39 | 3 | 945.120.19 | 366988 | <del>52,53</del>       | 47,09                  |
| 16,00 | 16,00 | 35 | 93  | 15,70 | 45 | 3 | 945.160.19 | 366989 | <del>79,56</del>       | 71,33                  |
| 20,00 | 20,00 | 40 | 104 | 19,70 | 54 | 3 | 945.200.19 | 366990 | <del>124,44</del>      | 111,57                 |
| 25,00 | 25,00 | 40 | 121 | 23,00 | 65 | 3 | 945.250.19 | 366991 | <del>204,00</del>      | 182,90                 |

## FRAISES CARBURES | SÉRIE COURTE

### DEUX DENTS - SÉRIE COURTE

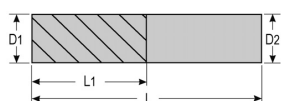

| D1  | L1 | L   | D2 H6 | Z | Code    | Prix €<br>net HT |
|-----|----|-----|-------|---|---------|------------------|
| 2   | 6  | 40  | 2     | 2 | 366200  | 9,64             |
| 2,5 | 8  | 40  | 2,5   | 2 | 366201  | 9,64             |
| 3   | 8  | 40  | 3     | 2 | 366202  | 9,64             |
| 3,5 | 8  | 50  | 3,5   | 2 | 366203  | 9,64             |
| 4   | 12 | 40  | 4     | 2 | 366204  | 9,64             |
| 4,5 | 12 | 40  | 4,5   | 2 | 366209  | 9,64             |
| 5   | 14 | 50  | 5     | 2 | 366205  | 9,64             |
| 5,5 | 14 | 50  | 5,5   | 2 | 366211  | 10,42            |
| 6   | 16 | 50  | 6     | 2 | 366206  | 10,42            |
| 6,5 | 16 | 60  | 6,5   | 2 | 366207  | 11,70            |
| 8   | 20 | 60  | 8     | 2 | 366208  | 11,70            |
| 10  | 22 | 70  | 10    | 2 | 366210* | 20,20            |
| 12  | 22 | 70  | 12    | 2 | 366212* | 27,34            |
| 14  | 22 | 83  | 14    | 2 | 366214* | 40,79            |
| 16  | 25 | 75  | 16    | 2 | 366216* | 44,73            |
| 18  | 26 | 92  | 18    | 2 | 366218* | 53,36            |
| 20  | 32 | 100 | 20    | 2 | 366220* | 78,58            |

\* Jusqu'à épuisement des stocks

### TROIS DENTS - SÉRIE COURTE

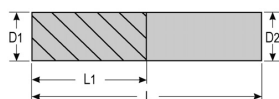

\* Jusqu'à épaisseur des stocks

| D1  | L1 | L   | D2 H6 | Z | Code    | Prix € net HT |
|-----|----|-----|-------|---|---------|---------------|
| 2   | 6  | 40  | 2     | 3 | 366300  | 9,34          |
| 2,5 | 10 | 40  | 2,5   | 3 | 366301  | 9,88          |
| 3   | 10 | 40  | 3     | 3 | 366302  | 9,64          |
| 3,5 | 8  | 50  | 3,5   | 3 | 366303  | 9,75          |
| 4   | 12 | 0   | 4     | 3 | 366304  | 9,88          |
| 4,5 | 12 | 40  | 4,5   | 3 | 366307  | 9,64          |
| 5   | 14 | 50  | 5     | 3 | 366305  | 9,64          |
| 5,5 | 14 | 50  | 5,5   | 3 | 366309  | 10,41         |
| 6   | 16 | 50  | 6     | 3 | 366306  | 10,41         |
| 6,5 | 16 | 60  | 6,5   | 3 | 366311  | 12,44         |
| 8   | 20 | 60  | 8     | 3 | 366308  | 12,89         |
| 10  | 22 | 70  | 10    | 3 | 366310  | 19,83         |
| 12  | 22 | 70  | 12    | 3 | 366312  | 29,41         |
| 14  | 25 | 75  | 14    | 3 | 366314* | 33,37         |
| 16  | 25 | 75  | 16    | 3 | 366316  | 56,67         |
| 18  | 32 | 100 | 18    | 3 | 366318* | 51,32         |
| 20  | 32 | 100 | 20    | 3 | 366320  | 88,66         |

## FRAISES CARBURES | SÉRIE COURTE DEUX TAILLES

### TROIS DENTS - SÉRIE COURTE



| D1 | L1 | L   | D2 H6 | Z | CYLINDRIQUE |       | WELDON |       |
|----|----|-----|-------|---|-------------|-------|--------|-------|
|    |    |     |       |   | Code        | Prix  | Code   | Prix  |
| 6  | 10 | 57  | 6     | 3 | 366866      | 10,97 | 366806 | 10,97 |
| 8  | 16 | 63  | 8     | 3 | 366868      | 15,86 | 366808 | 15,86 |
| 10 | 19 | 72  | 10    | 3 | 366870      | 21,18 | 366810 | 21,18 |
| 12 | 22 | 83  | 12    | 3 | 366872      | 30,52 | 366812 | 30,52 |
| 16 | 26 | 92  | 16    | 3 | 366876      | 50,97 | 366816 | 50,97 |
| 18 | 32 | 104 | 18    | 3 | -           | -     | -      | -     |
| 20 | 32 | 104 | 20    | 3 | 366880      | 79,54 | 366820 | 79,54 |

QUATRE DENTS - SÉRIE COURTE

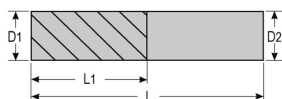

| D1  | L1 | L   | D2 H6 | Z | Code   | Prix € net HT |
|-----|----|-----|-------|---|--------|---------------|
| 2   | 6  | 40  | 2     | 4 | 366400 | 10,02         |
| 2,5 | 10 | 40  | 2,5   | 4 | 366401 | 10,02         |
| 3   | 10 | 40  | 3     | 4 | 366402 | 10,26         |
| 3,5 | 10 | 50  | 3,5   | 4 | 366403 | 10,02         |
| 4   | 11 | 50  | 4     | 4 | 366404 | 10,02         |
| 4,5 | 12 | 40  | 4,5   | 4 | 366407 | 10,90         |
| 5   | 13 | 50  | 5     | 4 | 366405 | 10,41         |
| 5,5 | 14 | 50  | 5,5   | 4 | 366409 | 14,61         |
| 6   | 13 | 57  | 6     | 4 | 366406 | 14,60         |
| 6,5 | 16 | 60  | 6,5   | 4 | 366411 | 18,39         |
| 8   | 19 | 63  | 8     | 4 | 366408 | 15,58         |
| 10  | 22 | 72  | 10    | 4 | 366410 | 23,23         |
| 12  | 26 | 83  | 12    | 4 | 366412 | 38,56         |
| 14  | 32 | 92  | 14    | 4 | 366414 | 53,01         |
| 16  | 32 | 92  | 16    | 4 | 366416 | 55,93         |
| 18  | 38 | 100 | 18    | 4 | 366418 | 78,64         |
| 20  | 38 | 100 | 20    | 4 | 366420 | 86,25         |

# FRAISES CARBURES | RN540 CINQ DENTS

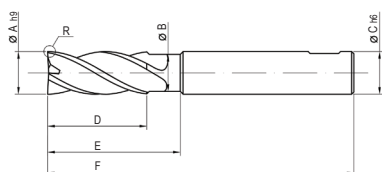

| Dimensions |      |    |    |    |     | Rayon | Articles      | Code   | Prix tarif<br>€ net HT | Prix promo<br>€ net HT |
|------------|------|----|----|----|-----|-------|---------------|--------|------------------------|------------------------|
| A          | B    | C  | D  | E  | F   | R     |               |        |                        |                        |
| 12         | 11   | 12 | 26 | 35 | 83  | 0,8   | PLAN N-39930  | 276088 | <del>97,75</del>       | 71,09                  |
| 12         | 11   | 12 | 26 | 35 | 83  | 2,5   | PLAN N-39929  | 276089 | <del>97,75</del>       | 71,09                  |
| 16         | 15   | 16 | 32 | 48 | 100 | 1,0   | PLAN N-33114  | 276093 | <del>135,00</del>      | 98,18                  |
| 16         | 15   | 16 | 32 | 48 | 100 | 2,5   | PLAN N-33115  | 276094 | <del>135,00</del>      | 98,18                  |
| 16         | 15   | 16 | 32 | 48 | 100 | 4,0   | PLAN N-33116  | 276095 | <del>135,00</del>      | 98,18                  |
| 20         | 18,8 | 20 | 38 | 50 | 104 | 2,5   | PLAN N-39210  | 276096 | <del>196,87</del>      | 143,18                 |
| 20         | 18,8 | 20 | 38 | 50 | 104 | 4,0   | PLAN N-39211  | 276097 | <del>196,87</del>      | 143,18                 |
| 25         | 23,5 | 25 | 45 | 60 | 121 | 2,5   | PLAN N-39212A | 276098 | <del>309,30</del>      | 224,95                 |
| 25         | 23,5 | 25 | 45 | 60 | 121 | 4,0   | PLAN N-39213A | 276099 | <del>309,30</del>      | 224,95                 |
| 25         | 23,5 | 25 | 45 | 60 | 121 | 6,0   | PLAN N-39928  | 276100 | <del>309,30</del>      | 224,95                 |

# FRAISES CARBURES | HSS CO5

## TROIS DENTS - FRAISE 90°



| D1    | ANGLE | L  | D2 H8 | Z | HSSE   |           | TIALN  |           |
|-------|-------|----|-------|---|--------|-----------|--------|-----------|
|       |       |    |       |   | CODE   | PRIX € HT | CODE   | PRIX € HT |
| 6,30  | 90°   | 44 | 5     | 3 | 011470 | 8,38      | 011480 | 12,17     |
| 8,30  | 90°   | 48 | 6     | 3 | 011471 | 9,15      | 011481 | 12,95     |
| 10,40 | 90°   | 50 | 6     | 3 | 011472 | 11,44     | 011482 | 15,22     |
| 12,40 | 90°   | 58 | 8     | 3 | 011473 | 12,96     | 011483 | 16,76     |
| 16,50 | 90°   | 62 | 8     | 3 | 011474 | 14,49     | 011484 | 18,28     |
| 20,50 | 90°   | 63 | 10    | 3 | 011475 | 19,06     | 011485 | 22,84     |
| 25,00 | 90°   | 67 | 10    | 3 | 011476 | 28,21     | 011486 | 32,00     |
| 31,00 | 90°   | 71 | 12    | 3 | 011477 | 40,41     | 011487 | 44,21     |

# FRAISES CARBURES | WX6 505 REVÊTUES



## FRAISES 2 TAILLES FINITION - SÉRIE MOYENNE

- NORME USINE
- COUPE AU CENTRE
- HÉLICE 40°



| D Js14 | Lt | LT  | d h8 | Z | Code   | Prix € net HT |
|--------|----|-----|------|---|--------|---------------|
| 3      | 8  | 52  | 6    | 4 | 015597 | 11,73         |
| 4      | 11 | 55  | 6    | 4 | 015598 | 11,73         |
| 5      | 13 | 57  | 6    | 4 | 015599 | 11,73         |
| 6      | 16 | 60  | 6    | 4 | 015600 | 11,73         |
| 7      | 22 | 72  | 10   | 4 | 015601 | 19,81         |
| 8      | 25 | 75  | 10   | 4 | 015602 | 19,81         |
| 9      | 25 | 75  | 10   | 4 | 015603 | 20,60         |
| 10     | 28 | 78  | 10   | 4 | 015604 | 20,60         |
| 11     | 28 | 85  | 12   | 4 | 015605 | 25,90         |
| 12     | 32 | 89  | 12   | 4 | 015606 | 25,90         |
| 13     | 32 | 89  | 12   | 4 | 015607 | 28,48         |
| 14     | 32 | 92  | 16   | 4 | 015617 | 33,53         |
| 15     | 36 | 96  | 16   | 4 | 015618 | 33,53         |
| 16     | 36 | 96  | 16   | 4 | 015608 | 33,53         |
| 17     | 40 | 200 | 16   | 4 | 015609 | 39,31         |
| 18     | 40 | 200 | 16   | 4 | 015610 | 39,31         |
| 19     | 45 | 105 | 16   | 4 | 015611 | 43,45         |
| 20     | 45 | 111 | 20   | 4 | 015612 | 43,45         |
| 22     | 46 | 111 | 20   | 5 | 015613 | 63,84         |
| 25     | 50 | 126 | 25   | 5 | 015614 | 67,07         |
| 30     | 63 | 139 | 25   | 6 | 015615 | 91,90         |
| 32     | 63 | 143 | 32   | 6 | 015616 | 96,81         |

# FRAISES À PLAQUETTES | HFMM

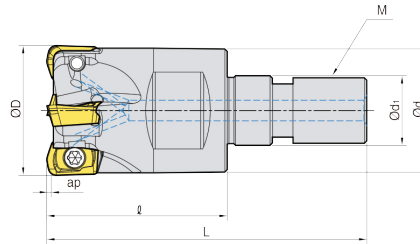

## FRAISE A PLAQUETTE GRANDE AVANCE

| FRAISES        | Ø D | Z | Code   | Prix tarif<br>€ net HT |
|----------------|-----|---|--------|------------------------|
| HFMM1008HR-M06 | 8   | 1 | 090960 | 102,89                 |
| HFMM1010HR-M06 | 10  | 2 | 090961 | 102,89                 |
| HFMM1011HR-M06 | 11  | 2 | 090962 | 102,89                 |
| HFMM1012HR-M06 | 12  | 3 | 090963 | 111,13                 |
| HFMM1013HR-M06 | 13  | 3 | 090964 | 111,13                 |
| HFMM1016HR-M08 | 16  | 4 | 090965 | 138,46                 |
| HFMM1017HR-M08 | 17  | 4 | 090966 | 138,46                 |
| HFMM1020HR-M10 | 20  | 5 | 090967 | 149,54                 |
| HFMM1021HR-M10 | 21  | 5 | 090968 | 149,54                 |
| HFMM1025HR-M12 | 25  | 6 | 090969 | 177,65                 |
| HFMM1026HR-M12 | 26  | 6 | 090970 | 177,65                 |
| HFMM1030HR-M16 | 30  | 7 | 090971 | 220,64                 |
| HFMM1032HR-M16 | 32  | 8 | 090972 | 238,29                 |
| HFMM1033HR-M16 | 33  | 8 | 090973 | 238,29                 |

| PLAQUETTES            | QTE | Code   | Prix unitaire<br>€ net HT |
|-----------------------|-----|--------|---------------------------|
| LPMT040210R-MF PC5300 | 10  | 090975 | 10,51                     |
| LPMT040210R-MF PC5400 | 10  | 090976 | 10,51                     |
| LPMT040220R-MF PC5300 | 10  | 090978 | 10,51                     |
| LPMT040220R-MF PC5400 | 10  | 090979 | 10,51                     |
| LPMW040210R PC2505    | 10  | 090980 | 10,51                     |
| LPMW040210R PC5300    | 10  | 090982 | 10,51                     |
| LPMW040220R PC2505    | 10  | 090983 | 10,51                     |
| LPMW040220R PC5300    | 10  | 090985 | 10,51                     |
| LPEW040210R PC2505    | 10  | 090986 | 12,82                     |
| LPEW040210R PC5300    | 10  | 090988 | 12,82                     |
| LPEW040220R PC2505    | 10  | 090989 | 12,82                     |
| LPEW040220R PC5300    | 10  | 090991 | 12,82                     |

### Application Area (ap & Diameter)

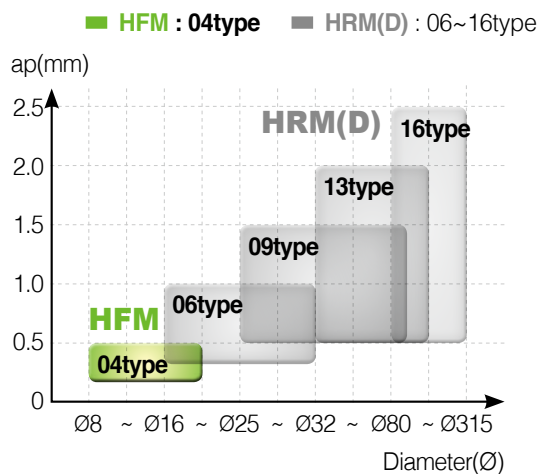

### Application Area (ap & fz)

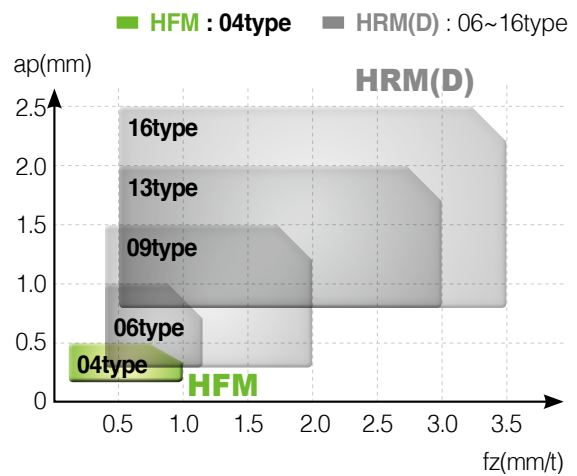

## RALLONGE VISSÉE

| RALLONGE                        | Code   | Prix tarif<br>€ net HT |
|---------------------------------|--------|------------------------|
| RALLONGE ACIER M6 D10 LU20 TL65 | 087446 | 71,80                  |
| RALLONGE ACIER M6 D12 LU20 TL65 | 087447 | 71,80                  |
| RALLONGE ACIER M6 D10 LU40 TL85 | 087448 | 71,80                  |
| RALLONGE ACIER M6 D12 LU20 TL85 | 087449 | 71,80                  |
| RALLONGE CARBURE M6 Q10 L60     | 087165 | 215,30                 |
| RALLONGE CARBURE M6 Q12 L65     | 087166 | 242,10                 |
| RALLONGE CARBURE M6 Q10 L80     | 087167 | 230,80                 |
| RALLONGE CARBURE M6 Q12 L85     | 087168 | 258,60                 |
| RALLONGE CARBURE M6 Q10 L100    | 087169 | 250,30                 |
| RALLONGE CARBURE M6 Q12 L105    | 087170 | 286,40                 |



10 PLAQUETTES ACHETÉES = 1 FRAISE A REMISE 50%

## FRAISES À PLAQUETTES | RM3 - ERM3



| Ø D       | PLAQUETTES RM3   ERM3  | BONUS SUPPLÉMENTAIRE |
|-----------|------------------------|----------------------|
| ≤ 50      | 10 PLAQUETTES ACHETÉES | R50% SUR LA FRAISE   |
| [63 ; 80] | 20 PLAQUETTES ACHETÉES | R50% SUR LA FRAISE   |
| ≥ 100     | 30 PLAQUETTES ACHETÉES | R50% SUR LA FRAISE   |

# FRAISES CARBURES À FILETER

## UNE DENT



| M<br>GROS | M<br>FIN | UNC<br>UNF    | d | D   | Z | I     | L  | Code   | Prix tarif<br>€ net HT | Prix promo<br>€ net HT |
|-----------|----------|---------------|---|-----|---|-------|----|--------|------------------------|------------------------|
| M2-M,2    | M1,8-M2  | N°2 (1,5xD)   | 3 | 1,5 | 3 | 3,80  | 39 | 093050 | <del>67,30</del>       | 50,00                  |
| M2-M2,2   | M1,8-M2  | N°2 (2,25xD)  | 3 | 1,5 | 3 | 5,40  | 39 | 093051 | <del>67,30</del>       | 50,00                  |
| M2,5      | M2,2     | N°3 (1,5xD)   | 3 | 1,9 | 3 | 4,30  | 39 | 093052 | <del>67,30</del>       | 50,00                  |
| M2,5      | M2,2     | N°3 (2,25xD)  | 3 | 1,9 | 3 | 6,20  | 39 | 093053 | <del>67,30</del>       | 50,00                  |
| -         | M2,5     | N°4 (1,5xD)   | 3 | 2,1 | 3 | 4,90  | 39 | 093054 | <del>67,30</del>       | 50,00                  |
| -         | M2,5     | N°4 (2,25xD)  | 3 | 2,1 | 3 | 7,10  | 39 | 093055 | <del>67,30</del>       | 50,00                  |
| M3        | -        | N°5 (1,5xD)   | 3 | 2,3 | 3 | 5,40  | 39 | 093056 | <del>67,30</del>       | 50,00                  |
| M3        | -        | N°5 (2,25xD)  | 3 | 2,3 | 3 | 7,80  | 39 | 093057 | <del>67,30</del>       | 50,00                  |
| M3,5      | M3       | N°6 (1,5xD)   | 3 | 2,6 | 3 | 6,10  | 39 | 093058 | <del>67,30</del>       | 50,00                  |
| M3,5      | M3       | N°6 (2,25xD)  | 3 | 2,6 | 3 | 8,70  | 39 | 093059 | <del>67,30</del>       | 50,00                  |
| M4        | M3,5-M4  | N°8 (1,5xD)   | 3 | 3,0 | 3 | 7,10  | 39 | 093060 | <del>67,30</del>       | 50,00                  |
| M4        | M3,5-M4  | N°8 (2,25xD)  | 3 | 3,0 | 3 | 10,00 | 39 | 093061 | <del>67,30</del>       | 50,00                  |
| M4,5      | M4,5     | N°10 (1,5xD)  | 4 | 3,6 | 3 | 8,30  | 50 | 093062 | <del>72,50</del>       | 54,00                  |
| M4,5      | M4,5     | N°10 (2,25xD) | 4 | 3,6 | 3 | 12,00 | 50 | 093063 | <del>72,50</del>       | 54,00                  |
| M5-M6     | M5-M6    | N°12 (1,5xD)  | 4 | 4,0 | 3 | 10,00 | 50 | 093064 | <del>72,50</del>       | 54,00                  |
| M5-M6     | M5-M6    | N°12 (2,25xD) | 4 | 4,0 | 3 | 15,00 | 50 | 093065 | <del>72,50</del>       | 54,00                  |

## DEUX DENTS



| M<br>GROS | M<br>FIN      | d | D   | Z | I     | L  | Code   | Prix tarif<br>€ net HT | Prix promo<br>€ net HT |
|-----------|---------------|---|-----|---|-------|----|--------|------------------------|------------------------|
| 0,40      | M2 (1,5xD)    | 3 | 1,5 | 3 | 3,40  | 39 | 093020 | <del>80,80</del>       | 60,00                  |
| 0,40      | M2 (2,25xD)   | 3 | 1,5 | 3 | 5,00  | 39 | 093021 | <del>80,80</del>       | 60,00                  |
| 0,45      | M2,2 (1,5xD)  | 3 | 1,6 | 3 | 3,80  | 39 | 093022 | <del>80,80</del>       | 60,00                  |
| 0,45      | M2,2 (2,25xD) | 3 | 1,6 | 3 | 5,40  | 39 | 093023 | <del>80,80</del>       | 60,00                  |
| 0,45      | M2,5 (1,5xD)  | 3 | 1,9 | 3 | 4,20  | 39 | 093024 | <del>80,80</del>       | 60,00                  |
| 0,45      | M2,5 (2,25xD) | 3 | 1,9 | 3 | 6,10  | 39 | 093025 | <del>80,80</del>       | 60,00                  |
| 0,50      | M3 (1,5xD)    | 3 | 2,3 | 3 | 5,00  | 39 | 093026 | <del>80,80</del>       | 60,00                  |
| 0,50      | M3 (2,25xD)   | 3 | 2,3 | 3 | 7,30  | 39 | 093027 | <del>80,80</del>       | 60,00                  |
| 0,60      | M3,5 (1,5xD)  | 3 | 2,6 | 3 | 6,00  | 39 | 093028 | <del>80,80</del>       | 60,00                  |
| 0,60      | M3,5 (2,25xD) | 3 | 2,6 | 3 | 8,50  | 39 | 093029 | <del>80,80</del>       | 60,00                  |
| 0,70      | M4 (1,5xD)    | 3 | 3,0 | 3 | 7,00  | 39 | 093030 | <del>80,80</del>       | 60,00                  |
| 0,70      | M4 (2,25xD)   | 3 | 3,0 | 3 | 10,00 | 39 | 093031 | <del>80,80</del>       | 60,00                  |
| 0,80      | M5 (1,5xD)    | 4 | 3,8 | 3 | 9,00  | 50 | 093032 | <del>87,00</del>       | 65,00                  |
| 0,80      | M5 (2,25xD)   | 4 | 3,8 | 3 | 12,00 | 50 | 093033 | <del>87,00</del>       | 65,00                  |
| 1,00      | M6 (1,5xD)    | 6 | 4,5 | 3 | 10,00 | 50 | 093034 | <del>104,10</del>      | 75,00                  |
| 1,00      | M6 (2,25xD)   | 6 | 4,5 | 3 | 15,00 | 50 | 093035 | <del>104,10</del>      | 75,00                  |
| 1,25      | M8 (1,5xD)    | 6 | 6,0 | 3 | 14,00 | 50 | 093036 | <del>104,10</del>      | 75,00                  |
| 1,25      | M8 (2,25xD)   | 6 | 6,0 | 3 | 19,00 | 50 | 093037 | <del>104,10</del>      | 75,00                  |

# FORETS HÉLICOÏDAUX CARBURE MONOBLOC

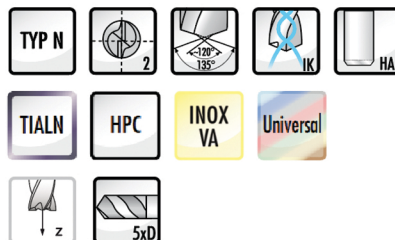
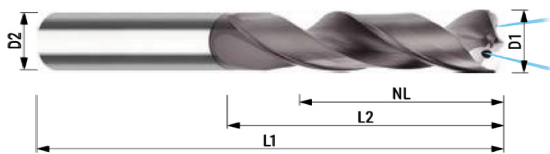

## Articles 845 ...

| D1<br>mm | D2<br>mm | L2<br>mm | L1<br>mm | NL<br>mm | Code   | Prix promo<br>€ net HT | D1<br>mm | D2<br>mm | L2<br>mm | L1<br>mm | NL<br>mm | Code   | Prix promo<br>€ net HT | D1<br>mm | D2<br>mm | L2<br>mm | L1<br>mm | NL<br>mm | Code   | Prix promo<br>€ net HT |  |
|----------|----------|----------|----------|----------|--------|------------------------|----------|----------|----------|----------|----------|--------|------------------------|----------|----------|----------|----------|----------|--------|------------------------|--|
| 3,00     | 6        | 28       | 66       | 23       | 272150 | 21,76                  | 6,80     | 8        | 53       | 91       | 43       | 272189 | 25,84                  | 10,70    | 12       | 71       | 118      | 56       | 272228 | 40,80                  |  |
| 3,10     | 6        | 28       | 66       | 23       | 272151 | 21,76                  | 6,90     | 8        | 53       | 91       | 43       | 272190 | 25,84                  | 10,80    | 12       | 71       | 118      | 56       | 272229 | 40,80                  |  |
| 3,20     | 6        | 28       | 66       | 23       | 272152 | 21,76                  | 7,00     | 8        | 53       | 91       | 43       | 272191 | 25,84                  | 10,90    | 12       | 71       | 118      | 56       | 272230 | 40,80                  |  |
| 3,30     | 6        | 28       | 66       | 23       | 272153 | 21,76                  | 7,10     | 8        | 53       | 91       | 43       | 272192 | 25,84                  | 11,00    | 12       | 71       | 118      | 56       | 272231 | 40,80                  |  |
| 3,40     | 6        | 28       | 66       | 23       | 272154 | 21,76                  | 7,20     | 8        | 53       | 91       | 43       | 272193 | 25,84                  | 11,10    | 12       | 71       | 118      | 56       | 272232 | 40,80                  |  |
| 3,50     | 6        | 28       | 66       | 23       | 272155 | 21,76                  | 7,30     | 8        | 53       | 91       | 43       | 272194 | 25,84                  | 11,20    | 12       | 71       | 118      | 56       | 272233 | 40,80                  |  |
| 3,60     | 6        | 28       | 66       | 23       | 272156 | 21,76                  | 7,40     | 8        | 53       | 91       | 43       | 272195 | 25,84                  | 11,30    | 12       | 71       | 118      | 56       | 272234 | 40,80                  |  |
| 3,70     | 6        | 28       | 66       | 23       | 272157 | 21,76                  | 7,50     | 8        | 53       | 91       | 43       | 272196 | 25,84                  | 11,40    | 12       | 71       | 118      | 56       | 272235 | 40,80                  |  |
| 3,80     | 6        | 36       | 74       | 29       | 272158 | 21,76                  | 7,60     | 8        | 53       | 91       | 43       | 272197 | 25,84                  | 11,50    | 12       | 71       | 118      | 56       | 272236 | 40,80                  |  |
| 3,90     | 6        | 36       | 74       | 29       | 272159 | 21,76                  | 7,70     | 8        | 53       | 91       | 43       | 272198 | 25,84                  | 11,60    | 12       | 71       | 118      | 56       | 272237 | 40,80                  |  |
| 4,00     | 6        | 36       | 74       | 29       | 272160 | 21,76                  | 7,80     | 8        | 53       | 91       | 43       | 272199 | 25,84                  | 11,70    | 12       | 71       | 118      | 56       | 272238 | 40,80                  |  |
| 4,10     | 6        | 36       | 74       | 29       | 272161 | 21,76                  | 7,90     | 8        | 53       | 91       | 43       | 272200 | 25,84                  | 11,80    | 12       | 71       | 118      | 56       | 272239 | 40,80                  |  |
| 4,20     | 6        | 36       | 74       | 29       | 272162 | 21,76                  | 8,00     | 8        | 53       | 91       | 43       | 272201 | 25,84                  | 11,90    | 12       | 71       | 118      | 56       | 272240 | 40,80                  |  |
| 4,30     | 6        | 36       | 74       | 29       | 272163 | 21,76                  | 8,10     | 10       | 61       | 103      | 49       | 272202 | 31,28                  | 12,00    | 12       | 71       | 118      | 56       | 272241 | 40,80                  |  |
| 4,40     | 6        | 36       | 74       | 29       | 272164 | 21,76                  | 8,20     | 10       | 61       | 103      | 49       | 272203 | 31,28                  | 12,20    | 14       | 77       | 124      | 60       | 272242 | 59,84                  |  |
| 4,50     | 6        | 36       | 74       | 29       | 272165 | 21,76                  | 8,30     | 10       | 61       | 103      | 49       | 272204 | 31,28                  | 12,30    | 14       | 77       | 124      | 60       | 272243 | 59,84                  |  |
| 4,60     | 6        | 36       | 74       | 29       | 272166 | 21,76                  | 8,40     | 10       | 61       | 103      | 49       | 272205 | 31,28                  | 12,50    | 14       | 77       | 124      | 60       | 272244 | 59,84                  |  |
| 4,65     | 6        | 36       | 74       | 29       | 272167 | 21,76                  | 8,50     | 10       | 61       | 103      | 49       | 272206 | 31,28                  | 12,80    | 14       | 77       | 124      | 60       | 272245 | 59,84                  |  |
| 4,70     | 6        | 36       | 74       | 29       | 272168 | 21,76                  | 8,60     | 10       | 61       | 103      | 49       | 272207 | 31,28                  | 13,00    | 14       | 77       | 124      | 60       | 272246 | 59,84                  |  |
| 4,80     | 6        | 44       | 82       | 35       | 272169 | 21,76                  | 8,70     | 10       | 61       | 103      | 49       | 272208 | 31,28                  | 13,50    | 14       | 77       | 124      | 60       | 272247 | 59,84                  |  |
| 4,90     | 6        | 44       | 82       | 35       | 272170 | 21,76                  | 8,80     | 10       | 61       | 103      | 49       | 272209 | 31,28                  | 13,80    | 14       | 77       | 124      | 60       | 272248 | 59,84                  |  |
| 5,00     | 6        | 44       | 82       | 35       | 272171 | 21,76                  | 8,90     | 10       | 61       | 103      | 49       | 272210 | 31,28                  | 14,00    | 14       | 77       | 124      | 60       | 272249 | 59,84                  |  |
| 5,10     | 6        | 44       | 82       | 35       | 272172 | 21,76                  | 9,00     | 10       | 61       | 103      | 49       | 272211 | 31,28                  | 14,50    | 16       | 83       | 133      | 63       | 272250 | 73,44                  |  |
| 5,20     | 6        | 44       | 82       | 35       | 272173 | 21,76                  | 9,10     | 10       | 61       | 103      | 49       | 272212 | 31,28                  | 14,80    | 16       | 83       | 133      | 63       | 272251 | 73,44                  |  |
| 5,30     | 6        | 44       | 82       | 35       | 272174 | 21,76                  | 9,20     | 10       | 61       | 103      | 49       | 272213 | 31,28                  | 15,00    | 16       | 83       | 133      | 63       | 272252 | 73,44                  |  |
| 5,40     | 6        | 44       | 82       | 35       | 272175 | 21,76                  | 9,30     | 10       | 61       | 103      | 49       | 272214 | 31,28                  | 15,50    | 16       | 83       | 133      | 63       | 272253 | 73,44                  |  |
| 5,50     | 6        | 44       | 82       | 35       | 272176 | 21,76                  | 9,40     | 10       | 61       | 103      | 49       | 272215 | 31,28                  | 15,80    | 16       | 83       | 133      | 63       | 272254 | 73,44                  |  |
| 5,60     | 6        | 44       | 82       | 35       | 272177 | 21,76                  | 9,50     | 10       | 61       | 103      | 49       | 272216 | 31,28                  | 16,00    | 16       | 83       | 133      | 63       | 272255 | 73,44                  |  |
| 5,70     | 6        | 28       | 66       | 35       | 272178 | 21,76                  | 9,60     | 10       | 61       | 103      | 49       | 272217 | 31,28                  | 16,50    | 18       | 93       | 143      | 71       | 272256 | 100,64                 |  |
| 5,80     | 6        | 28       | 66       | 35       | 272179 | 21,76                  | 9,70     | 10       | 61       | 103      | 49       | 272218 | 31,28                  | 16,80    | 18       | 93       | 143      | 71       | 272257 | 100,64                 |  |
| 5,90     | 6        | 28       | 66       | 35       | 272180 | 21,76                  | 9,80     | 10       | 61       | 103      | 49       | 272219 | 31,28                  | 17,00    | 18       | 93       | 143      | 71       | 272258 | 100,64                 |  |
| 6,00     | 6        | 28       | 66       | 35       | 272181 | 21,76                  | 9,90     | 10       | 61       | 103      | 49       | 272220 | 31,28                  | 17,50    | 18       | 93       | 143      | 71       | 272259 | 100,64                 |  |
| 6,10     | 8        | 53       | 91       | 43       | 272182 | 21,76                  | 10,00    | 10       | 61       | 103      | 49       | 272221 | 31,28                  | 17,80    | 18       | 93       | 143      | 71       | 272260 | 100,64                 |  |
| 6,20     | 8        | 53       | 91       | 43       | 272183 | 25,84                  | 10,10    | 12       | 71       | 118      | 56       | 272222 | 40,80                  | 18,00    | 18       | 93       | 143      | 71       | 272261 | 100,64                 |  |
| 6,30     | 8        | 53       | 91       | 43       | 272184 | 25,84                  | 10,20    | 12       | 71       | 118      | 56       | 272223 | 40,80                  | 18,50    | 18       | 93       | 143      | 71       | 272262 | 127,84                 |  |
| 6,40     | 8        | 53       | 91       | 43       | 272185 | 25,84                  | 10,30    | 12       | 71       | 118      | 56       | 272224 | 40,80                  | 19,00    | 18       | 93       | 143      | 71       | 272263 | 127,84                 |  |
| 6,50     | 8        | 53       | 91       | 43       | 272186 | 25,84                  | 10,40    | 12       | 71       | 118      | 56       | 272225 | 40,80                  | 19,50    | 18       | 93       | 143      | 71       | 272264 | 127,84                 |  |
| 6,60     | 8        | 53       | 91       | 43       | 272187 | 25,84                  | 10,50    | 12       | 71       | 118      | 56       | 272226 | 40,80                  | 20,00    | 18       | 93       | 143      | 71       | 272265 | 127,84                 |  |
| 6,70     | 8        | 53       | 91       | 43       | 272188 | 25,84                  | 10,60    | 12       | 71       | 118      | 56       | 272227 | 40,80                  |          |          |          |          |          |        |                        |  |

# FORETS CYLINDRIQUES COURTS

## HSSCO5 TYPE N - SÉRIE COURTE

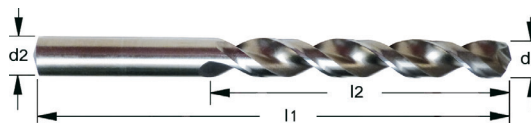
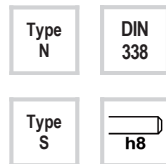

| D1<br>mm | L1<br>mm | L2<br>mm | Code    | Prix pièce<br>€ net HT | PRIX LOT<br>PAR 10 | D1<br>mm | D2<br>mm | L2<br>mm | Code    | Prix pièce<br>€ net HT | PRIX LOT<br>PAR 10 | D1<br>mm | D2<br>mm | L2<br>mm | Code    | Prix pièce<br>€ net HT | PRIX LOT<br>PAR 10 |
|----------|----------|----------|---------|------------------------|--------------------|----------|----------|----------|---------|------------------------|--------------------|----------|----------|----------|---------|------------------------|--------------------|
| 1,00     | 34       | 12       | 022700S | 0,61                   | 6,10               | 4,90     | 86       | 52       | 022778S | 1,38                   | 13,80              | 8,80     | 125      | 81       | 022858S | 4,33                   | 43,30              |
| 1,10     | 36       | 14       | 022702* | 0,69                   | 6,90               | 5,00     | 86       | 52       | 022780S | 1,38                   | 13,80              | 8,90     | 125      | 81       | 022860S | 4,49                   | 44,90              |
| 1,20     | 38       | 16       | 022704* | 0,69                   | 6,90               | 5,10     | 86       | 52       | 022782S | 1,38                   | 13,80              | 9,00     | 125      | 81       | 022862S | 4,49                   | 44,90              |
| 1,25     | 38       | 16       | 022914* | 0,80                   | 8,00               | 5,20     | 86       | 52       | 022784S | 1,41                   | 14,10              | 9,10     | 125      | 81       | 022864S | 4,99                   | 49,90              |
| 1,30     | 38       | 16       | 022706* | 0,69                   | 6,90               | 5,25     | 86       | 52       | 022922  | 1,95                   | 19,50              | 9,20     | 125      | 81       | 022866S | 5,02                   | 50,20              |
| 1,40     | 40       | 18       | 022708* | 0,69                   | 6,90               | 5,30     | 86       | 52       | 022786S | 1,41                   | 14,10              | 9,25     | 125      | 81       | 022929  | 4,89                   | 48,90              |
| 1,50     | 40       | 18       | 022710S | 0,61                   | 6,10               | 5,40     | 93       | 57       | 022788S | 1,49                   | 14,90              | 9,30     | 125      | 81       | 022868S | 5,04                   | 50,40              |
| 1,60     | 43       | 20       | 022712S | 0,66                   | 6,60               | 5,50     | 93       | 57       | 022790S | 1,49                   | 14,90              | 9,40     | 125      | 81       | 022870S | 5,07                   | 50,70              |
| 1,70     | 43       | 20       | 022714S | 0,66                   | 6,60               | 5,60     | 93       | 57       | 022792S | 1,49                   | 14,90              | 9,50     | 125      | 81       | 022872S | 5,07                   | 50,70              |
| 1,75     | 46       | 22       | 022915  | 0,82                   | 8,20               | 5,70     | 93       | 57       | 022794S | 1,49                   | 14,90              | 9,60     | 125      | 81       | 022874S | 5,10                   | 51,00              |
| 1,80     | 46       | 22       | 022716S | 0,66                   | 6,60               | 5,75     | 93       | 57       | 022923  | 2,08                   | 20,80              | 9,70     | 133      | 87       | 022876S | 5,15                   | 51,50              |
| 1,90     | 46       | 22       | 022718S | 0,72                   | 7,20               | 5,80     | 93       | 57       | 022796S | 1,54                   | 15,40              | 9,75     | 133      | 87       | 022930  | 4,91                   | 49,10              |
| 2,00     | 49       | 24       | 022720S | 0,74                   | 7,40               | 5,90     | 93       | 57       | 022798S | 1,54                   | 15,40              | 9,80     | 133      | 87       | 022878S | 5,29                   | 52,90              |
| 2,10     | 49       | 24       | 022722S | 0,74                   | 7,40               | 6,00     | 93       | 57       | 022800S | 1,52                   | 15,20              | 9,90     | 133      | 87       | 022880S | 5,43                   | 54,30              |
| 2,20     | 53       | 27       | 022724S | 0,74                   | 7,40               | 6,10     | 101      | 63       | 022802S | 1,62                   | 16,20              | 10,00    | 133      | 87       | 022882S | 5,48                   | 54,80              |
| 2,25     | 53       | 27       | 022916  | 0,84                   | 8,40               | 6,20     | 101      | 63       | 022804S | 1,65                   | 16,50              | 10,10    | 133      | 87       | 022883S | 5,51                   | 55,10              |
| 2,30     | 53       | 27       | 022726S | 0,77                   | 7,70               | 6,25     | 101      | 63       | 022924  | 2,39                   | 23,90              | 10,20    | 133      | 87       | 022884S | 5,70                   | 57,00              |
| 2,40     | 57       | 30       | 022728S | 0,77                   | 7,70               | 6,30     | 101      | 63       | 022806S | 1,76                   | 17,60              | 10,25    | 133      | 87       | 022885  | 5,80                   | 58,00              |
| 2,50     | 57       | 30       | 022730S | 0,77                   | 7,70               | 6,40     | 101      | 63       | 022808S | 1,76                   | 17,60              | 10,30    | 133      | 87       | 022886S | 5,70                   | 57,00              |
| 2,60     | 57       | 30       | 022732S | 0,80                   | 8,00               | 6,50     | 101      | 63       | 022810S | 1,76                   | 17,60              | 10,40    | 133      | 87       | 022887S | 5,73                   | 57,30              |
| 2,70     | 61       | 33       | 022734S | 0,80                   | 8,00               | 6,60     | 101      | 63       | 022812S | 1,82                   | 18,20              | 10,50    | 133      | 87       | 022888S | 5,76                   | 57,60              |
| 2,75     | 61       | 33       | 022917  | 0,99                   | 9,90               | 6,70     | 101      | 63       | 022814S | 1,85                   | 18,50              | 10,60    | 133      | 87       | 022889  | 5,82                   | 58,20              |
| 2,80     | 61       | 33       | 022736S | 0,80                   | 8,00               | 6,75     | 109      | 69       | 022816  | 2,65                   | 26,50              | 10,70    | 142      | 94       | 022890S | 5,76                   | 57,60              |
| 2,90     | 61       | 33       | 022738S | 0,80                   | 8,00               | 6,80     | 109      | 69       | 022818S | 1,85                   | 18,50              | 10,80    | 142      | 94       | 022891S | 5,84                   | 58,40              |
| 3,00     | 61       | 33       | 022740S | 0,80                   | 8,00               | 6,90     | 109      | 69       | 022820S | 1,96                   | 19,60              | 10,90    | 142      | 94       | 022892  | 5,82                   | 58,20              |
| 3,10     | 65       | 36       | 022742  | 0,88                   | 8,80               | 7,00     | 109      | 69       | 022822S | 1,96                   | 19,60              | 11,00    | 142      | 94       | 022893s | 5,95                   | 59,50              |
| 3,20     | 65       | 36       | 022744S | 0,85                   | 8,50               | 7,10     | 109      | 69       | 022824S | 2,09                   | 20,90              | 11,10    | 142      | 94       | 022894s | 6,31                   | 63,10              |
| 3,25     | 65       | 36       | 022918  | 0,95                   | 9,50               | 7,20     | 109      | 69       | 022826S | 2,09                   | 20,90              | 11,20    | 142      | 94       | 022895s | 6,89                   | 68,90              |
| 3,30     | 65       | 36       | 022746S | 0,95                   | 9,50               | 7,25     | 109      | 69       | 022925  | 3,15                   | 31,50              | 11,30    | 142      | 94       | 022896S | 7,39                   | 73,90              |
| 3,40     | 70       | 39       | 022748S | 1,10                   | 11,00              | 7,30     | 109      | 69       | 022828S | 2,15                   | 21,50              | 11,40    | 142      | 94       | 022897S | 7,44                   | 74,40              |
| 3,50     | 70       | 39       | 022750S | 1,16                   | 11,60              | 7,40     | 109      | 69       | 022830S | 2,15                   | 21,50              | 11,50    | 142      | 94       | 022898S | 7,44                   | 74,40              |
| 3,60     | 70       | 39       | 022752S | 1,19                   | 11,90              | 7,50     | 117      | 75       | 022832S | 2,29                   | 22,90              | 11,60    | 142      | 94       | 022899  | 6,91                   | 69,10              |
| 3,70     | 70       | 39       | 022754S | 1,21                   | 12,10              | 7,60     | 117      | 75       | 022834S | 2,34                   | 23,40              | 11,70    | 142      | 94       | 022900S | 7,44                   | 74,40              |
| 3,75     | 70       | 39       | 022919  | 1,32                   | 13,20              | 7,70     | 117      | 75       | 022836S | 2,40                   | 24,00              | 11,80    | 142      | 94       | 022901S | 7,44                   | 74,40              |
| 3,80     | 75       | 43       | 022756S | 1,21                   | 12,10              | 7,75     | 117      | 75       | 022926  | 3,44                   | 34,40              | 11,90    | 151      | 101      | 022902  | 6,91                   | 69,10              |
| 3,90     | 75       | 43       | 022758S | 1,24                   | 12,40              | 7,80     | 117      | 75       | 022838S | 2,43                   | 24,30              | 12,00    | 151      | 101      | 022903S | 7,88                   | 78,80              |
| 4,00     | 75       | 43       | 022760S | 1,19                   | 11,90              | 7,90     | 117      | 75       | 022840S | 2,48                   | 24,80              | 12,10    | 151      | 101      | 022904S | 7,99                   | 79,90              |
| 4,10     | 75       | 43       | 022762S | 1,24                   | 12,40              | 8,00     | 117      | 75       | 022842S | 2,76                   | 27,60              | 12,20    | 151      | 101      | 022905S | 7,99                   | 79,90              |
| 4,20     | 75       | 43       | 022764S | 1,24                   | 12,40              | 8,10     | 117      | 75       | 022844S | 3,45                   | 34,50              | 12,30    | 151      | 101      | 022906S | 8,02                   | 80,20              |
| 4,25     | 75       | 43       | 022920  | 1,34                   | 13,40              | 8,20     | 117      | 75       | 022846S | 3,61                   | 36,10              | 12,40    | 151      | 101      | 022907S | 8,08                   | 80,80              |
| 4,30     | 80       | 47       | 022766S | 1,27                   | 12,70              | 8,25     | 117      | 75       | 022927  | 3,82                   | 38,20              | 12,50    | 151      | 101      | 022908S | 8,10                   | 81,00              |
| 4,40     | 80       | 47       | 022768S | 1,27                   | 12,70              | 8,30     | 117      | 75       | 022848S | 3,67                   | 36,70              | 12,60    | 151      | 101      | 022909S | 8,16                   | 81,60              |
| 4,50     | 80       | 47       | 022770S | 1,30                   | 13,00              | 8,40     | 117      | 75       | 022845S | 3,86                   | 38,60              | 12,70    | 151      | 101      | 022910S | 8,27                   | 82,70              |
| 4,60     | 80       | 47       | 022772S | 1,30                   | 13,00              | 8,50     | 117      | 75       | 022852S | 3,67                   | 36,70              | 12,80    | 151      | 101      | 022911S | 8,82                   | 88,20              |
| 4,70     | 80       | 47       | 022774S | 1,30                   | 13,00              | 8,60     | 125      | 81       | 022854S | 4,49                   | 44,90              | 12,90    | 151      | 101      | 022912S | 9,65                   | 96,50              |
| 4,75     | 80       | 47       | 022921  | 1,49                   | 14,90              | 8,70     | 125      | 81       | 022856S | 4,49                   | 44,90              | 13,00    | 151      | 101      | 022913S | 9,65                   | 96,50              |
| 4,80     | 86       | 52       | 022776S | 1,30                   | 13,00              | 8,75     | 125      | 81       | 022928  | 3,95                   | 39,50              | 14,00    | 160      | 108      | 022931  | 9,70                   | 97,00              |

## SÉRIE COURTE

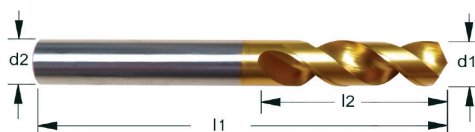

| D1<br>mm | L1<br>mm | L2<br>mm | D2<br>mm | Code<br>7572P | Prix tarif<br>€ net HT |
|----------|----------|----------|----------|---------------|------------------------|
| 1,30     | 40       | 8        | 3        | 028719        | 8,24                   |
| 2,00     | 44       | 12       | 3        | 028720        | 7,40                   |
| 2,50     | 46       | 14       | 3        | 028725        | 8,78                   |
| 3,00     | 48       | 16       | 3        | 028730        | 8,78                   |
| 3,30     | 50       | 18       | 4        | 028733        | 10,59                  |
| 3,50     | 52       | 20       | 4        | 028735        | 10,59                  |
| 4,00     | 54       | 22       | 4        | 028740        | 11,43                  |
| 4,20     | 66       | 22       | 6        | 028742        | 13,02                  |
| 4,50     | 68       | 24       | 6        | 028745        | 13,02                  |
| 4,55     | 68       | 24       | 6        | 028746        | 18,68                  |
| 4,65     | 68       | 24       | 6        | 028744        | 18,68                  |
| 5,00     | 70       | 26       | 6        | 028750        | 14,59                  |
| 5,10     | 70       | 26       | 6        | 028751        | 17,50                  |
| 5,50     | 72       | 28       | 6        | 028755        | 17,50                  |
| 5,55     | 72       | 28       | 6        | 028756        | 24,00                  |
| 5,90     | 72       | 28       | 6        | 028757        | 20,72                  |
| 6,00     | 72       | 28       | 6        | 028760        | 20,72                  |
| 6,50     | 75       | 31       | 8        | 028765        | 20,72                  |
| 6,80     | 78       | 34       | 8        | 028766        | 23,54                  |
| 6,90     | 79       | 34       | 8        | 028769        | 23,54                  |
| 7,00     | 78       | 34       | 8        | 028770        | 25,03                  |
| 7,50     | 78       | 34       | 8        | 028775        | 25,03                  |
| 8,00     | 81       | 37       | 8        | 028777        | 25,74                  |
| 8,30     | 81       | 37       | 8        | 028778        | 28,40                  |
| 8,50     | 87       | 37       | 10       | 028785        | 28,40                  |
| 8,90     | 87       | 37       | 10       | 028786        | 30,21                  |
| 9,00     | 90       | 40       | 10       | 028787        | 30,21                  |
| 9,50     | 90       | 40       | 10       | 028795        | 32,09                  |
| 10,00    | 93       | 43       | 10       | 028800        | 35,31                  |
| 10,20    | 100      | 43       | 12       | 028802        | 38,05                  |
| 10,50    | 100      | 43       | 12       | 028805        | 38,05                  |
| 11,00    | 104      | 47       | 12       | 028806        | 42,13                  |
| 11,50    | 104      | 47       | 12       | 028815        | 47,32                  |
| 12,00    | 108      | 51       | 12       | 028820        | 51,32                  |

| D1<br>mm | L1<br>mm | L2<br>mm | Code<br>65689P | Prix tarif<br>€ net HT |
|----------|----------|----------|----------------|------------------------|
| 2,00     | 44       | 16       | 028520         | 6,15                   |
| 2,50     | 50       | 20       | 028525         | 6,23                   |
| 3,00     | 54       | 22       | 028530         | 6,23                   |
| 3,30     | 57       | 24       | 028533         | 9,38                   |
| 3,50     | 61       | 26       | 028535         | 9,38                   |
| 4,00     | 65       | 29       | 028540         | 9,85                   |
| 4,10     | 65       | 29       | 028541         | 10,46                  |
| 4,20     | 65       | 29       | 028542         | 10,46                  |
| 4,30     | 65       | 29       | 028543         | 11,92                  |
| 4,50     | 69       | 32       | 028545         | 10,46                  |
| 5,00     | 74       | 35       | 028550         | 12,23                  |
| 5,10     | 74       | 35       | 028551         | 13,69                  |
| 5,50     | 80       | 38       | 028555         | 13,69                  |
| 6,00     | 80       | 38       | 028560         | 14,08                  |
| 6,20     | 86       | 42       | 028562         | 22,00                  |
| 6,50     | 86       | 42       | 028565         | 19,38                  |
| 6,80     | 92       | 46       | 028568         | 22,92                  |
| 6,90     | 92       | 46       | 028569         | 22,92                  |
| 7,00     | 92       | 46       | 028570         | 20,08                  |
| 7,50     | 92       | 46       | 028575         | 21,00                  |
| 8,00     | 98       | 50       | 028580         | 21,77                  |
| 8,50     | 98       | 50       | 028585         | 25,92                  |
| 9,00     | 105      | 54       | 028590         | 25,23                  |
| 9,50     | 105      | 54       | 028595         | 30,15                  |
| 10,00    | 111      | 58       | 028600         | 30,15                  |
| 10,20    | 111      | 58       | 028602         | 32,85                  |
| 10,50    | 111      | 58       | 028605         | 32,85                  |
| 11,00    | 119      | 63       | 028610         | 49,77                  |
| 11,50    | 119      | 63       | 028615         | 51,85                  |
| 12,00    | 127      | 68       | 028620         | 53,69                  |

# FORETS À POINTER | HSS CO8

FORETS NC 90° ET NC 120°

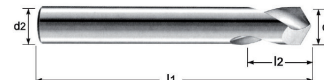
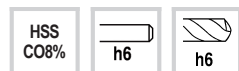

| D1 | L1  | L2 | D2 | HSSE   |               | TIALN  |               | HSSE   |               | TIALN  |               |
|----|-----|----|----|--------|---------------|--------|---------------|--------|---------------|--------|---------------|
|    |     |    |    | CODE   | PRIX € NET HT | CODE   | PRIX € NET HT | CODE   | PRIX € NET HT | CODE   | PRIX € NET HT |
| 3  | 46  | 12 | 3  | 028101 | 4,37          | 028201 | 6,21          | 028120 | 4,34          | 028220 | 6,21          |
| 4  | 55  | 12 | 4  | 028102 | 4,59          | 028202 | 7,36          | 028121 | 4,54          | 028221 | 7,36          |
| 5  | 60  | 15 | 5  | 028103 | 4,67          | 028203 | 8,40          | 028122 | 4,70          | 028222 | 8,40          |
| 6  | 66  | 20 | 6  | 028104 | 5,05          | 028204 | 8,80          | 028123 | 5,05          | 028223 | 8,80          |
| 8  | 79  | 25 | 8  | 028105 | 5,91          | 028205 | 10,07         | 028124 | 5,89          | 028224 | 10,07         |
| 10 | 89  | 25 | 10 | 028106 | 7,56          | 028206 | 13,20         | 028125 | 7,56          | 028225 | 13,20         |
| 12 | 102 | 30 | 12 | 028107 | 11,13         | 028207 | 17,96         | 028126 | 11,13         | 028226 | 17,96         |
| 14 | 115 | 35 | 14 | 028108 | 16,96         | 028208 | 24,54         | -      | -             | -      | -             |
| 16 | 115 | 35 | 16 | 028109 | 18,76         | 028209 | 27,13         | 028127 | 18,76         | 028227 | 27,13         |
| 20 | 131 | 40 | 20 | 028110 | 31,20         | 028211 | 44,76         | 028128 | 31,20         | 028228 | 44,76         |

# FORETS À PLAQUETTES | KING DRILL - KED DRILL



## KING DRILL

CAPACITÉ EXISTE DU Ø 12 AU Ø 60,5  
| INCREMENTATION 0,5 |  
RATIO 2D | 3D | 4D | 5D

## KED DRILL

CAPACITÉ EXISTE DU Ø 12 AU Ø 60,5  
| INCREMENTATION 0,5 |  
RATIO 2D | 3D | 4D



10 PLAQUETTES INTER ET EXTER ACHETÉES = 1 FRAISE A REMISE 50%

# TARAUDS MACHINE HAUTE PERFORMANCE



HSSE

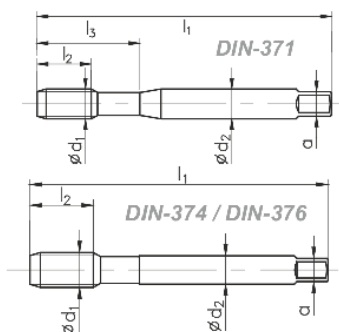

TYPE DE MATÉRIEL  
REVÊTEMENT  
CHANFREIN

| M  | P | L1 | L2 | L2  | L3 | D2 | a |  | INDEX |
|----|---|----|----|-----|----|----|---|--|-------|
| D1 |   |    |    | R40 |    |    |   |  |       |

|     |      |     |    |    |    |       |      |      |      |
|-----|------|-----|----|----|----|-------|------|------|------|
| M3  | 0,50 | 56  | 10 | 5  | 18 | 3,5   | 2,7  | 2,50 | 0030 |
| M4  | 0,70 | 63  | 12 | 7  | 21 | 4,5   | 3,4  | 3,30 | 0040 |
| M5  | 0,80 | 70  | 14 | 8  | 25 | 6,00  | 4,90 | 4,20 | 0050 |
| M6  | 1,00 | 80  | 18 | 10 | 35 | 6,00  | 4,90 | 5,00 | 0060 |
| M8  | 1,25 | 90  | 20 | 13 | 35 | 8,00  | 6,20 | 6,80 | 0080 |
| M10 | 1,50 | 100 | 20 | 15 | 39 | 10,00 | 8,00 | 8,50 | 0100 |

|          |      |     |    |    |   |      |      |      |      |
|----------|------|-----|----|----|---|------|------|------|------|
| M8x1     | 1,00 | 90  | 20 | 10 | - | 6,00 | 4,90 | 7,00 | 0083 |
| M10x1    | 1,00 | 90  | 20 | 13 | - | 7,00 | 5,50 | 9,00 | 0103 |
| M10x1,25 | 1,25 | 100 | 20 | 15 | - | 7,00 | 5,50 | 8,80 | 0104 |

|     |      |     |    |    |   |       |       |       |      |
|-----|------|-----|----|----|---|-------|-------|-------|------|
| M12 | 1,75 | 110 | 24 | 18 | - | 9,00  | 7,00  | 10,20 | 0120 |
| M14 | 2,00 | 110 | 25 | 20 | - | 11,00 | 9,00  | 12,00 | 0140 |
| M16 | 2,00 | 110 | 32 | 20 | - | 12,00 | 9,00  | 14,00 | 0160 |
| M18 | 2,50 | 125 | 32 | 25 | - | 14,00 | 11,00 | 15,50 | 0180 |
| M20 | 2,50 | 140 | 32 | 25 | - | 16,00 | 12,00 | 17,50 | 0200 |
| M22 | 2,50 | 140 | 32 | 25 | - | 18,00 | 14,50 | 19,50 | 0220 |
| M24 | 3,00 | 160 | 38 | 30 | - | 18,00 | 4,50  | 21,00 | 0240 |
| M27 | 3,00 | 160 | 38 | 30 | - | 20,00 | 16,00 | 24,00 | 0270 |
| M30 | 3,50 | 180 | 40 | 35 | - | 22,00 | 18,00 | 26,00 | 0300 |
| M33 | 3,50 | 180 | 45 | 35 | - | 25,00 | 22,00 | 29,50 | 0330 |
| M36 | 4,00 | 200 | 50 | 40 | - | 28,00 | 22,00 | 32,00 | 0360 |

|         |      |     |    |   |   |       |      |       |      |
|---------|------|-----|----|---|---|-------|------|-------|------|
| M12x1,5 | 1,50 | 100 | 20 | 5 | - | 9,00  | 7,00 | 10,20 | 0125 |
| M14x1,5 | 1,50 | 100 | 20 | 7 | - | 11,00 | 9,00 | 12,00 | 0145 |
| M16x1,5 | 1,50 | 100 | 20 | 8 | - | 12,00 | 9,00 | 14,00 | 0162 |

**800X**

C-R40-TN



HSSE  
TN  
C / 2-3P

B-TN



HSSE  
TN  
B / 4-5P

| CODE | C2-513X01 | PRIX | CODE | C2-113X01 | PRIX |
|------|-----------|------|------|-----------|------|
|------|-----------|------|------|-----------|------|

DIN-371

|        |                  |       |        |                  |       |
|--------|------------------|-------|--------|------------------|-------|
| 045751 | <del>12,71</del> | 9,24  | 045362 | <del>11,72</del> | 8,52  |
| 045753 | <del>12,90</del> | 9,39  | 045364 | <del>11,90</del> | 8,65  |
| 045756 | <del>13,92</del> | 10,12 | 045367 | <del>12,87</del> | 9,36  |
| 045758 | <del>14,37</del> | 10,45 | 045369 | <del>13,32</del> | 9,69  |
| 045761 | <del>17,16</del> | 12,48 | 045372 | <del>15,93</del> | 11,59 |
| 045765 | <del>22,47</del> | 16,34 | 045376 | <del>20,91</del> | 15,21 |

C2-513X01

C2-113X01

DIN-371

|        |                  |       |        |                  |       |
|--------|------------------|-------|--------|------------------|-------|
| 045492 | <del>21,29</del> | 15,48 | 045486 | <del>19,65</del> | 14,29 |
| 045493 | <del>26,00</del> | 18,91 | 045487 | <del>24,14</del> | 17,55 |
| 045494 | <del>29,51</del> | 21,46 | 045488 | <del>27,35</del> | 19,89 |

D2-513X01

C2-113X01

DIN-376

|        |                   |        |        |                   |        |
|--------|-------------------|--------|--------|-------------------|--------|
| 045778 | <del>31,38</del>  | 22,82  | 045389 | <del>31,38</del>  | 22,82  |
| 045782 | <del>41,55</del>  | 30,22  | 045393 | <del>41,55</del>  | 30,22  |
| 045787 | <del>44,97</del>  | 32,71  | 045399 | <del>44,97</del>  | 32,71  |
| 045790 | <del>61,16</del>  | 44,48  | 045402 | <del>61,16</del>  | 44,48  |
| 045794 | <del>66,71</del>  | 48,51  | 045406 | <del>66,71</del>  | 48,51  |
| 045798 | <del>90,54</del>  | 65,85  | 045410 | <del>90,54</del>  | 65,85  |
| 045802 | <del>91,43</del>  | 66,46  | 045414 | <del>91,43</del>  | 66,46  |
| 045808 | <del>117,26</del> | 85,28  | 045420 | <del>117,26</del> | 85,28  |
| 045813 | <del>137,64</del> | 100,10 | 045425 | <del>137,64</del> | 100,10 |
| 045818 | <del>186,57</del> | 137,14 | 045430 | <del>186,57</del> | 137,14 |
| 045823 | <del>266,78</del> | 194,02 | 045434 | <del>266,78</del> | 194,02 |

D2-513X01

C2-113X01

DIN-374

|        |                  |       |        |                  |       |
|--------|------------------|-------|--------|------------------|-------|
| 045495 | <del>36,32</del> | 26,41 | 045489 | <del>33,63</del> | 24,46 |
| 045496 | <del>48,33</del> | 35,15 | 045490 | <del>44,63</del> | 32,45 |
| 045497 | <del>50,46</del> | 36,70 | 045491 | <del>46,65</del> | 33,93 |



**HSSE  
PM**

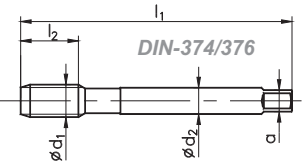
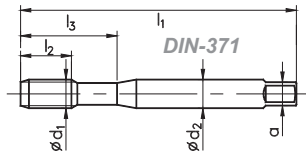

| ISO | Nr. mat.<br>No. mat. | Vc<br>[m/min] |
|-----|----------------------|---------------|
| P   | 1+8 10+11            | 20-40         |
|     | 9 13+14              | 5-15          |
| M   | 1+3                  | 5-15          |
| K   | 1+6                  | 10-30         |
| N   | 1+10                 | 10-30         |
| S   | 1+3 6                | 5-15          |



**TOLÉRANCE  
REVÊTEMENT  
ENTRÉE  
GOJURE**

| M   | P    | L1  | L2 | L3 | D2  | a   |       |
|-----|------|-----|----|----|-----|-----|-------|
| 2   | 0,4  | 45  | 8  | 12 | 2,8 | 2,1 | 1,6   |
| 2,5 | 0,45 | 50  | 5  | 14 | 2,8 | 2,1 | 2,05  |
| 3   | 0,50 | 56  | 5  | 18 | 3,5 | 2,1 | 2,50  |
| 4   | 0,70 | 63  | 7  | 21 | 4,5 | 3,4 | 3,30  |
| 5   | 0,80 | 70  | 8  | 25 | 6   | 4,9 | 4,20  |
| 6   | 1,00 | 80  | 10 | 30 | 6   | 4,9 | 5,00  |
| 8   | 1,25 | 90  | 13 | 35 | 8   | 6,2 | 6,80  |
| 10  | 1,50 | 100 | 15 | 39 | 10  | 8   | 8,50  |
| 12  | 1,75 | 110 | 18 | -  | 9   | 7   | 10,20 |
| 14  | 2,00 | 110 | 20 | -  | 11  | 9   | 12,00 |
| 16  | 2,00 | 110 | 20 | -  | 12  | 9   | 14,00 |

**ISO2 (H6)  
HL  
B = 4 - 5 FILETS  
DROITE**

| C4-118M01      |                        |
|----------------|------------------------|
| CODE           | PRIX                   |
| <b>DIN-371</b> |                        |
| 045711         | <del>18,18</del> 15,67 |
| 045712         | <del>18,18</del> 15,67 |
| 045713         | <del>14,07</del> 12,12 |
| 045714         | <del>14,02</del> 12,78 |
| 045715         | <del>16,09</del> 13,88 |
| 045716         | <del>16,68</del> 14,38 |
| 045717         | <del>20,03</del> 17,28 |
| 045718         | <del>26,35</del> 22,71 |

**ISO2 (H6)  
HL  
C = 2 - 3 FILETS  
HÉLICOÏDALE**

| C4-528M01      |                        |
|----------------|------------------------|
| CODE           | PRIX                   |
| <b>DIN-371</b> |                        |
| 045719         | <del>20,21</del> 17,41 |
| 045720         | <del>20,21</del> 17,41 |
| 045721         | <del>15,63</del> 13,48 |
| 045722         | <del>16,47</del> 14,19 |
| 045723         | <del>17,89</del> 15,41 |
| 045724         | <del>18,52</del> 15,97 |
| 045725         | <del>22,26</del> 19,19 |
| 045726         | <del>29,27</del> 25,24 |

**D4-118M31**

| DIN-376 |                        |
|---------|------------------------|
| 045727  | <del>38,82</del> 33,47 |
| 045728  | <del>50,89</del> 43,86 |
| 045729  | <del>54,71</del> 47,17 |

**D4-528M01**

| DIN-376 |                        |
|---------|------------------------|
| 045730  | <del>34,13</del> 37,19 |
| 045731  | <del>56,53</del> 48,72 |
| 045732  | <del>60,79</del> 52,40 |



**TARAUDS H2ECO**

- DIN 371 JUSQU'AU M10
- DIN 37 AU-DELÀ

**TOLÉRANCE  
ENTRÉE  
GOJURE**

| M3  | x | 0,5  | 045104 |
|-----|---|------|--------|
| M4  | x | 0,7  | 045109 |
| M5  | x | 0,80 | 045112 |
| M6  | x | 1,00 | 045115 |
| M8  | x | 1,25 | 045119 |
| M10 | x | 1,50 | 045121 |
| M12 | x | 1,75 | 045123 |
| M14 | x | 2,00 | 045125 |
| M16 | x | 2,00 | 045127 |
| M18 | x | 2,50 | 045129 |
| M20 | x | 2,50 | 045131 |

**6H  
C = 2 - 3 FILETS  
HÉLICOÏDALE**

|     |   |      | CODE   | Prix tarif<br>€ net HT | Prix promo<br>€ net HT |
|-----|---|------|--------|------------------------|------------------------|
| M3  | x | 0,5  | 045104 | <del>6,63</del>        | 4,42                   |
| M4  | x | 0,7  | 045109 | <del>6,63</del>        | 4,42                   |
| M5  | x | 0,80 | 045112 | <del>6,78</del>        | 4,52                   |
| M6  | x | 1,00 | 045115 | <del>6,78</del>        | 4,52                   |
| M8  | x | 1,25 | 045119 | <del>10,18</del>       | 6,78                   |
| M10 | x | 1,50 | 045121 | <del>11,35</del>       | 7,57                   |
| M12 | x | 1,75 | 045123 | <del>15,18</del>       | 10,12                  |
| M14 | x | 2,00 | 045125 | <del>23,98</del>       | 15,98                  |
| M16 | x | 2,00 | 045127 | <del>26,13</del>       | 17,42                  |
| M18 | x | 2,50 | 045129 | <del>27,51</del>       | 20,38                  |
| M20 | x | 2,50 | 045131 | <del>32,82</del>       | 24,30                  |

# TARAUDS À REFOULER

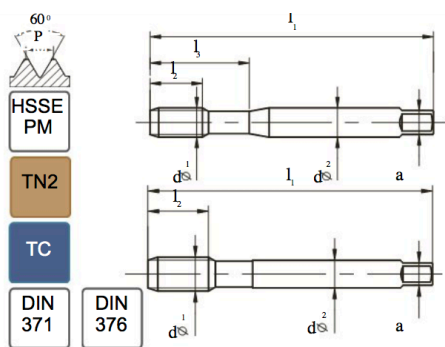

C-SR-TN2



C-SR-TC



## QUALITÉ DU MATÉRIEL REVÊTEMENT ENTRÉE

| M<br>D1 | P    | L1  | L2 | L3 | D2  | a   |      | INDEX | HSSE-PM<br>TN2<br>C/2-3 P<br>C4-923005 |                  | HSSE-PM<br>TC<br>C/2-3 P<br>C4-925005 |                 |                  |       |
|---------|------|-----|----|----|-----|-----|------|-------|--|------------------|---------------------------------------|-----------------|------------------|-------|
|         |      |     |    |    |     |     |      |       | CODE                                   | PRIX<br>DIN-371  | CODE                                  | PRIX<br>DIN-371 |                  |       |
| 3       | 0,50 | 59  | 18 | 18 | 3,5 | 2,7 | 2,80 | 0030  | 045735                                 | <del>18,71</del> | 12,90                                 | 045973          | <del>19,86</del> | 15,27 |
| 4       | 0,70 | 63  | 21 | 21 | 4,5 | 3,4 | 3,70 | 0040  | 045736                                 | <del>18,71</del> | 12,90                                 | 045974          | <del>19,86</del> | 15,27 |
| 5       | 0,80 | 70  | 25 | 25 | 6   | 4,9 | 4,65 | 0050  | 045737                                 | <del>19,65</del> | 13,55                                 | 045975          | <del>19,86</del> | 15,27 |
| 6       | 1,00 | 80  | 30 | 30 | 6   | 4,9 | 5,60 | 0060  | 045738                                 | <del>20,96</del> | 14,45                                 | 045976          | <del>22,94</del> | 17,63 |
| 8       | 1,00 | 90  | 35 | 35 | 8   | 6,2 | 7,45 | 0080  | 045739                                 | <del>25,04</del> | 17,28                                 | 045977          | <del>18,02</del> | 21,56 |
| 10      | 1,50 | 100 | 35 | 35 | 10  | 8   | 9,35 | 0100  | 045740                                 | <del>30,52</del> | 23,48                                 | 045978          | <del>34,31</del> | 26,38 |

# LUBRIFIANTS POUR TARAUDAGE

| LUBRIFIANT                            | Articles | Code   | Prix tarif<br>€ net HT |
|---------------------------------------|----------|--------|------------------------|
| RTD SPRAY LUBRIFIANT   AEROSOL 400 ML | R53011   | 049002 | 27,70                  |
| RTD PÂTE LUBRIFIANTE   POT 500G       | R53023   | 049003 | 19,30                  |
| RTD LUBRIFIANT LIQUIDE   BURETTE 400G | R53072   | 049004 | 27,70                  |



# BARRES ALESAGES CARBURE MONOBLOC

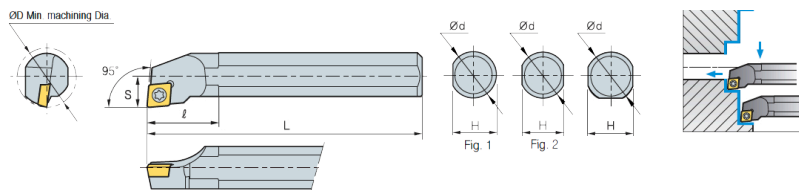

## C..SCLCR ...

| Ø D | Ø d | L   | BARRE ALESAGE | Code   | Prix tarif<br>€ net HT | Prix promo<br>€ net HT | PLAQUETTES            | Code   | Prix tarif<br>€ net HT | Prix promo<br>€ net HT |
|-----|-----|-----|---------------|--------|------------------------|------------------------|-----------------------|--------|------------------------|------------------------|
| 5   | 4   | 90  | C04G-SCLCR-03 | 090100 | <del>94,67</del>       | 71,33                  | CCET 030102PL PC9030  | 079208 | <del>11,77</del>       | 7,76                   |
| 6   | 5   | 100 | C05G-SCLCR-03 | 090101 | <del>94,67</del>       | 71,33                  | CCET 0301005PL PC9030 | 079209 | <del>11,77</del>       | 7,76                   |
| 7   | 6   | 100 | C06G-SCLCR-03 | 090102 | <del>94,67</del>       | 71,33                  | CCET 040102PL PC9030  | 079210 | <del>11,77</del>       | 7,76                   |
|     |     |     |               |        |                        |                        | CCET 0401005PL PC9030 | 079211 | <del>11,77</del>       | 7,76                   |

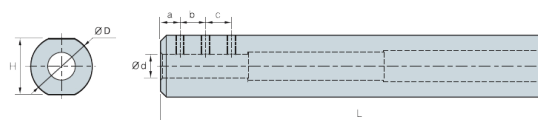
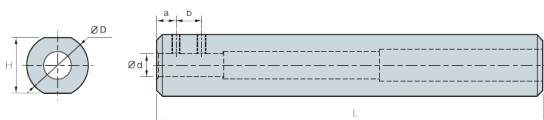

## SL160...

| Ø d | a | b | c | Ø D | H  | L   | VIS | CLE   | MANCHON | Code   | Prix tarif<br>€ net HT | Prix promo<br>€ net HT |
|-----|---|---|---|-----|----|-----|-----|-------|---------|--------|------------------------|------------------------|
| 4   | 5 | 6 | - | 16  | 14 | 100 | M4  | HW20L | SL1604  | 090110 | <del>107,31</del>      | 86,02                  |
| 5   | 5 | 8 | - | 16  | 14 | 100 | M4  | HW20L | SL1605  | 090111 | <del>107,31</del>      | 86,02                  |
| 6   | 5 | 6 | 6 | 16  | 14 | 100 | M4  | HW20L | SL1606  | 090112 | <del>107,31</del>      | 86,02                  |



### E..SCLCR/SCLCL/SDUCR ...

| Articles       | CODE   | Prix tarif<br>€ HT | Prix promo<br>€ net HT |
|----------------|--------|--------------------|------------------------|
| E08K SCLCR-06  | 090002 | <del>135,83</del>  | 91,31                  |
| E10M SCLCR-06  | 090003 | <del>185,22</del>  | 124,52                 |
| E12Q SCLCR-06  | 090004 | <del>226,38</del>  | 152,20                 |
| E16R SCLCR09T3 | 090005 | <del>337,51</del>  | 226,91                 |
| E20S SCLCR09T3 | 090006 | <del>617,40</del>  | 415,08                 |
| E25T SCLCR-12  | 090007 | <del>1082,51</del> | 727,78                 |
| E08K SCLCL06   | 090009 | <del>135,83</del>  | 91,32                  |
| E10M SCLCL06   | 090010 | <del>185,22</del>  | 124,52                 |
| E12Q SCLCL06   | 090011 | <del>226,38</del>  | 152,20                 |
| E16R SCLCL09T3 | 090012 | <del>337,51</del>  | 226,91                 |
| E20S SCLCL09T3 | 090013 | <del>617,40</del>  | 415,08                 |
| E25T SCLCL12   | 090014 | <del>1082,51</del> | 727,78                 |
| E08K SDUCR07   | 090040 | <del>115,30</del>  | 80,45                  |
| E10M SDUCR07   | 090041 | <del>185,22</del>  | 124,52                 |
| E12Q SDUCR07   | 090042 | <del>226,38</del>  | 152,20                 |
| E16R SDUCR11   | 090043 | <del>337,51</del>  | 226,91                 |
| E20S SDUCR11   | 090044 | <del>617,40</del>  | 415,08                 |
| E25T SDUCR11   | 090045 | <del>1082,51</del> | 727,78                 |
| E08K SDUCR07   | 090046 | <del>115,30</del>  | 80,45                  |
| E10M SDUCR07   | 090047 | <del>185,22</del>  | 124,52                 |
| E12Q SDUCR07   | 090048 | <del>226,38</del>  | 152,20                 |
| E16R SDUCR11   | 090049 | <del>337,51</del>  | 226,91                 |
| E20S SDUCR11   | 090050 | <del>617,40</del>  | 415,08                 |
| E25T SDUCR11   | 090051 | <del>1082,51</del> | 727,78                 |

# PORTE-OUTILS | ECO TURN MULTIFONCTION

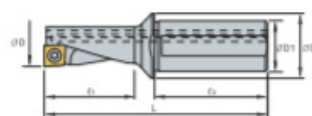

| Ø D | Ø D1 | Ø D2 | L1    | L2    | L      | Articles   | Code   | Prix tarif<br>€ net HT |
|-----|------|------|-------|-------|--------|------------|--------|------------------------|
| 10  | 12   | 16   | 22,50 | 42,00 | 69,50  | MT10R-2.25 | 090905 | 220,15                 |
| 12  | 16   | 20   | 27,00 | 45,00 | 78,00  | MT12R-2.25 | 090906 | 226,95                 |
| 14  | 16   | 20   | 31,50 | 45,00 | 83,50  | MT14R-2.25 | 090907 | 231,59                 |
| 16  | 20   | 25   | 36,00 | 50,00 | 94,00  | MT16R-2.25 | 090908 | 236,31                 |
| 20  | 25   | 32   | 45,00 | 56,00 | 111,00 | MT20R-2.25 | 090909 | 278,00                 |



1 PORTE-OUTILS ACHETÉ = 10 PLAQUETTES QC... OFFERTES

# PORTE-OUTILS | EXTÉRIEURS



## PORTE - OUTILS A BRIDE TYPE D

| UTILISATIONS                              | CARRE    | Prix unitaire<br>€ net HT |
|---|----------|---------------------------|
| POUR PLAQUETTES TYPE CN.../WN.../TN.../DN | CARRE 20 | 56,00                     |
| POUR PLAQUETTES TYPE CN.../WN.../TN.../DN | CARRE 25 | 59,00                     |



## PORTE - OUTILS A LEVIER TYPE P

| UTILISATIONS                           | CARRE    | Prix unitaire<br>€ net HT |
|--|----------|---------------------------|
| POUR PLAQUETTES TYPE CN.../WN.../TN... | CARRE 20 | 29,00                     |
| POUR PLAQUETTES TYPE CN.../WN.../TN... | CARRE 25 | 32,00                     |
| POUR PLAQUETTES DN                     | CARRE 20 | 37,00                     |
| POUR PLAQUETTES DN                     | CARRE 25 | 42,00                     |

# MEULEUSES



MEULEUSE DE TYPE CRAYON | SPM80R |

- 80 000 TR/MIN
- SANS HUILE
- P : 160 G | L : 130 MM
- POUR FRAISES SUR TIGE DE 3 MM



MEULEUSE DROITE À TURBINE | ST100 |

- 100 000 TR/MIN
- SANS HUILE
- P : 240 G | L : 150 MM
- POUR FRAISES SUR TIGE DE 3 MM

| Articles                 | Code   | Prix tarif<br>€ net HT | Prix promo<br>€ net HT |
|--------------------------|--------|------------------------|------------------------|
| SPM80R - MEULEUSE CRAYON | 365971 | <del>379,94</del>      | 299,90                 |
| ST100 - MEULEUSE DROITE  | 365972 | <del>434,95</del>      | 345,90                 |
| PROCUT-IS-10X3MM-6AS     | -      | <del>100,93</del>      | OFFERT                 |



COFFRET FRAISES MINIATURES | PROCUT-IS-10X3MM-6AS |

- GAMME AERO
- SPECIALE ALLIAGES NICKEL ET TITANE



1 MEULEUSE DROITE ACHETÉE = 1 COFFRET DE FRAISES LIMES OFFERT

**ACTION  
PROMOTIONNELLE**

**POUR 1 MEULEUSE SMD30LR À 555 €**

RECEVEZ GRATUITEMENT 160 € DE FRAISES LIME CARBURE ROTATIVE EN QUEUE 6



**ACTION  
PROMOTIONNELLE**

**POUR 1 POLISSEUSE SB5LR À 617 €**

RECEVEZ GRATUITEMENT 60 ROUE À LAMELLE CÉRAMIQUE [GRAIN 40 | 60 | 80]



**ACTION  
PROMOTIONNELLE**

**POUR 1 PONCEUSE RENVOI D'ANGLE RA20LR À 527 €**

RECEVEZ GRATUITEMENT 200 DISQUE QUICK-CHANGE D50 [GRAIN 40 | 50 | 60] + 1 PLATEAU QUICK CHANGE



# ACCESSOIRES | KIT DINAPLUS

## KITDP00000

REF 420536  
**280€ HT**

KIT DINAPLUS  
DYNAPLUS KIT  
DYNAPLUS KIT  
KIT DINAPLUS



## ART. 26000

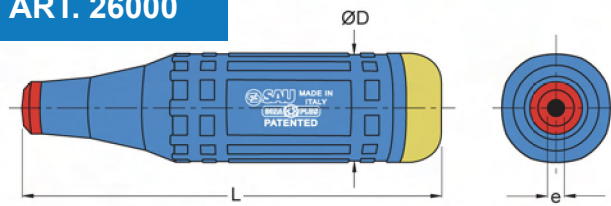

MANICO CACCIAVITE DINAPLUS  
DYNAPLUS SCREWDRIVER HANDLE  
DYNAPLUS SCHRAUBENDREHER-GRIFF  
MANCHE TOURNEVIS DYNAPLUS

## CONTENU DU KIT

- n°1 TORX T6 (Nm0,6)
- n°1 TORX T7 (Nm0,9)
- n°1 TORX T8 (Nm1,2)
- n°1 TORX T9 (Nm1,4)
- n°1 TORX T10 (Nm2,0)
- n°1 TORX T15 (Nm3,0)
- n°1 TORX T20 (Nm5,0)
- n°1 TORX PLUS IP6 (Nm0,6)
- n°1 TORX PLUS IP7 (Nm0,9)
- n°1 TORX PLUS IP8 (Nm1,2)
- n°1 TORX PLUS IP9 (Nm1,4)
- n°1 TORX PLUS IP10 (Nm2,0)
- n°1 TORX PLUS IP15 (Nm3,0)
- n°A1 TORX PLUS IP20 (Nm5,0)

| ART.  | (mm) |      |       |             |
|-------|------|------|-------|-------------|
|       | e    | ØD   | L     |             |
| 26000 | 7,3  | 33,2 | 131,4 | 270../290.. |

## ART. 270..

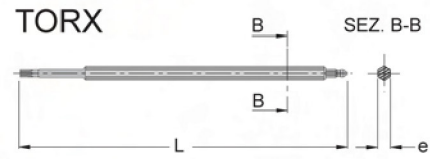

LAMA INTERCAMBIABILE  
INTERCHANGEABLE BLADE  
AUSTAUSCHBARES MESSER  
LAME INTERCHANGEABLE

## ART. 290..

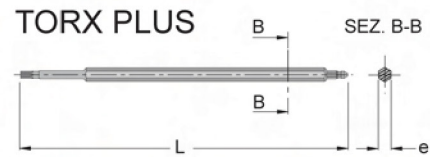

LAMA INTERCAMBIABILE  
INTERCHANGEABLE BLADE  
AUSTAUSCHBARES MESSER  
LAME INTERCHANGEABLE

| ART.  | (mm) Torx |      | e   | L   | Nm <sup>Max</sup> | TIPO<br>TYPE |
|-------|-----------|------|-----|-----|-------------------|--------------|
|       | Torx      | Plus |     |     |                   |              |
| 27006 | 6         | —    | 6,3 | 175 | 0,6               | Torx         |
| 27007 | 7         | —    | 6,3 | 175 | 0,9               |              |
| 27008 | 8         | —    | 6,3 | 175 | 1,2               |              |
| 27009 | 9         | —    | 6,3 | 175 | 1,4               |              |
| 27010 | 10        | —    | 6,3 | 175 | 2,0               |              |
| 27015 | 15        | —    | 6,3 | 175 | 3,0               |              |
| 27020 | 20        | —    | 6,3 | 175 | 5,0               | Torx Plus    |
| 29006 | —         | 6IP  | 6,3 | 175 | 0,6               |              |
| 29007 | —         | 7IP  | 6,3 | 175 | 0,9               |              |
| 29008 | —         | 8IP  | 6,3 | 175 | 1,2               |              |
| 29009 | —         | 9IP  | 6,3 | 175 | 1,4               |              |
| 29010 | —         | 10IP | 6,3 | 175 | 2,0               |              |
| 29015 | —         | 15IP | 6,3 | 175 | 3,0               |              |
| 29020 | —         | 20IP | 6,3 | 175 | 5,0               |              |

# ACCESSOIRES | ROULEAU ATELIER ABRASIF

ROULEAU ATELIER - ABRASIF - KL 385 JF



| DIM     | GRAIN | Code   | Prix tarif<br>€ net HT |
|---------|-------|--------|------------------------|
| 40x25 M | GR40  | 190003 | 17,00                  |
| 40x25 M | GR50  | 190004 | 17,00                  |
| 40x25 M | GR60  | 190005 | 16,00                  |
| 40x25 M | GR80  | 190006 | 14,00                  |
| 40x25 M | GR100 | 190007 | 14,00                  |
| 40x25 M | GR120 | 190008 | 14,00                  |
| 40x25 M | GR150 | 190009 | 14,00                  |
| 40x25 M | GR180 | 190010 | 14,00                  |
| 40x25 M | GR220 | 190011 | 14,00                  |
| 38x25 M | GR240 | 190012 | 14,00                  |
| 38x25 M | GR280 | 190013 | 14,00                  |
| 38x25 M | GR320 | 190014 | 14,00                  |
| 38x25 M | GR360 | 190015 | 19,00                  |
| 38x25 M | GR400 | 190016 | 19,00                  |
| 38x25 M | GR600 | 190017 | 23,00                  |

POUR L'ACHAT DE 5 ROULEAUX :

REMISE  
10%

POUR L'ACHAT DE 10 ROULEAUX :

REMISE  
20%

PRIX PROMOTIONNELS NET HT - OFFRE VALABLE DANS LA LIMITE DES STOCKS DISPONIBLES - VALIDITE 30-06-2018

## TECHMO

SIEGE SOCIAL  
30 rue de Montaran  
**45400 FLEURY LES AUBRAIS**  
commercial.techmo@techmo.fr  
Tél. : 02 38 61 48 10  
Fax : 02 38 84 39 63

## TECHMO

18 chemin de la Violette  
**31240 L'UNION**  
magasin.toulouse@techmo.fr  
Tél. : 05 61 61 34 35  
Fax : 05 61 61 34 44

## TECHMO

9 rue Laplace  
**33700 MERIGNAC**  
magasin.merignac@techmo.fr  
Tél. : 05 61 61 34 35  
Fax : 05 61 61 34 44

## TECHMO

95 rue Normandie Niemen  
**64121 SERRES CASTET**  
magasin.pau@techmo.fr  
Tél. : 05 59 90 34 10  
Fax : 05 59 90 08 59

## TECHMO

Parc du Chêne  
12 rue du 35e Régiment d'Aviation  
**69500 BRON**  
magasin.vaulx-en-velin@techmo.fr  
Tél. : 02 38 61 48 10  
Fax : 05 38 84 39 63

## SATECH

28, rue Alain Gerbault  
ZAC du panorama  
**72100 LE MANS**  
magasin@satech.fr  
Tél. : 02 43 40 05 05  
Fax : 02 43 40 00 99