

# COMPLÉMENT OPTI PROD 2020

PRIX PROMOTIONNELS NET HT  
OFFRE VALABLE JUSQU'AU 31-12-2020

*accessoires machines outils  
outils coupants*



**TeCHmo  
SaTeCH**  
GROUPE

Partenaire d'usinage

REMISE  
ADDITIONNELLE  
DE 5%

AVEC LE CODE TEC-SAT-112020\*

\*Code valable uniquement sur les commandes web

# FORETS CARBURE | SERIE 503

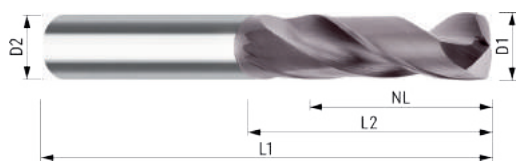

D1M7 mm	D2H6 mm	L1 mm	L2 mm	NL	CODE	PRIX PROMO € HT
3,00	6,00	62	20	14	270765	25,45
3,10	6,00	62	20	14	270766	25,45
3,20	6,00	62	20	14	270767	25,45
3,30	6,00	62	20	14	270768	25,45
3,40	6,00	62	20	14	270769	25,45
3,50	6,00	62	20	14	270770	25,45
3,60	6,00	62	20	14	270771	25,45
3,70	6,00	62	20	14	270772	25,45
3,80	6,00	66	24	17	270773	25,45
3,90	6,00	66	24	17	270774	25,45
4,00	6,00	66	24	17	270775	25,45
4,10	6,00	66	24	17	270776	25,45
4,20	6,00	66	24	17	270777	25,45
4,30	6,00	66	24	17	270778	25,45
4,40	6,00	66	24	17	270779	25,45
4,50	6,00	66	24	17	270780	25,45
4,60	6,00	66	24	17	270781	25,45
4,70	6,00	66	24	17	270782	25,45
4,80	6,00	66	28	20	270783	25,45
4,90	6,00	66	28	20	270784	25,45
5,00	6,00	66	28	20	270785	25,45
5,10	6,00	66	28	20	270786	25,45
5,20	6,00	66	28	20	270787	25,45
5,30	6,00	66	28	20	270788	25,45
5,40	6,00	66	28	20	270789	25,45
5,50	6,00	66	28	20	270790	25,45
5,60	6,00	66	28	20	270791	25,45
5,70	6,00	66	28	20	270792	25,45
5,80	6,00	66	28	20	270793	25,45
5,90	6,00	66	28	20	270794	25,45
6,00	6,00	66	28	20	270795	25,45
6,10	8,00	79	34	24	270796	27,62
6,20	8,00	79	34	24	270797	27,62
6,30	8,00	79	34	24	270798	27,62
6,40	8,00	79	34	24	270799	27,62
6,50	8,00	79	34	24	270800	27,62
6,60	8,00	79	34	24	270801	27,62
6,70	8,00	79	34	24	270802	27,62
6,80	8,00	79	34	24	270803	27,62
6,90	8,00	79	34	24	270804	27,62
7,00	8,00	79	34	24	270805	27,62
7,10	8,00	79	41	29	270806	27,62
7,20	8,00	79	41	29	270807	27,62
7,30	8,00	79	41	29	270808	27,62
7,40	8,00	79	41	29	270809	27,62
7,50	8,00	79	41	29	270810	27,62
7,60	8,00	79	41	29	270811	27,62
7,70	8,00	79	41	29	270812	27,62
7,80	8,00	79	41	29	270813	27,62
7,90	8,00	79	41	29	270814	27,62
8,00	8,00	79	41	29	270815	26,78
8,10	10,00	89	47	35	270816	37,78
8,20	10,00	89	47	35	270817	37,78
8,30	10,00	89	47	35	270818	37,78
8,40	10,00	89	47	35	270819	37,78
8,50	10,00	89	47	35	270820	37,78
8,60	10,00	89	47	35	270821	37,78
8,70	10,00	89	47	35	270822	37,78
8,80	10,00	89	47	35	270823	37,78
8,90	10,00	89	47	35	270824	37,78

D1M7 mm	D2H6 mm	L1 mm	L2 mm	NL	CODE	PRIX PROMO € HT
9,00	10,00	89	47	35	270825	37,78
9,10	10,00	89	47	35	270826	37,78
9,20	10,00	89	47	35	270827	37,78
9,30	10,00	89	47	35	270828	37,78
9,40	10,00	89	47	35	270829	37,78
9,50	10,00	89	47	35	270830	37,78
9,60	10,00	89	47	35	270831	37,78
9,70	10,00	89	47	35	270832	37,78
9,80	10,00	89	47	35	270833	37,78
9,90	10,00	89	47	35	270834	37,78
10,00	10,00	89	47	35	270835	37,78
10,10	12,00	102	55	40	270836	50,88
10,20	12,00	102	55	40	270837	50,88
10,30	12,00	102	55	40	270838	50,88
10,40	12,00	102	55	40	270839	50,88
10,50	12,00	102	55	40	270840	50,88
10,60	12,00	102	55	40	270841	50,88
10,70	12,00	102	55	40	270842	50,88
10,80	12,00	102	55	40	270843	50,88
10,90	12,00	102	55	40	270844	50,88
11,00	12,00	102	55	40	270845	50,88
11,10	12,00	102	55	40	270846	50,88
11,20	12,00	102	55	40	270847	50,88
11,30	12,00	102	55	40	270848	50,88
11,40	12,00	102	55	40	270849	50,88
11,50	12,00	102	55	40	270850	50,88
11,60	12,00	102	55	40	270851	50,88
11,70	12,00	102	55	40	270852	50,88
11,80	12,00	102	55	40	270853	50,88
11,90	12,00	102	55	40	270854	50,88
12,00	12,00	102	55	40	270855	46,84
12,30	14,00	107	60	43	270856	64,71
12,50	14,00	107	60	43	270857	64,71
12,80	14,00	107	60	43	270858	64,71
13,00	14,00	107	60	43	270859	64,71
13,50	14,00	107	60	43	270860	64,71
13,80	14,00	107	60	43	270861	64,71
14,00	14,00	107	60	43	270862	64,71
14,50	16,00	115	65	45	270863	87,24
14,80	16,00	115	65	45	270864	87,24
15,00	16,00	115	65	45	270865	87,24
15,50	16,00	115	65	45	270866	87,24
15,80	16,00	115	65	45	270867	87,24
16,00	16,00	115	65	45	270868	87,24
16,50	18,00	123	73	51	270869	87,24
16,80	18,00	123	73	51	270870	112,67
17,00	18,00	123	73	51	270871	112,67
17,50	18,00	123	73	51	270872	112,67
17,80	18,00	123	73	51	270873	112,67
18,00	18,00	123	73	51	270874	112,67
18,50	20,00	131	79	55	270875	112,67
19,00	20,00	131	79	55	270876	141,76
19,50	20,00	131	79	55	270877	141,76
19,80	20,00	131	79	55	270878	141,76
20,00	20,00	131	79	55	270879	141,76

# FORETS CARBURE | SERIE 505

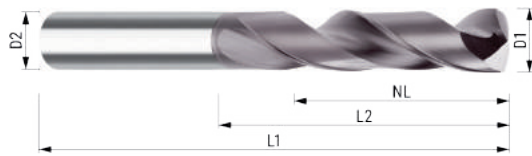

D1M7 mm	D2H6 mm	L1 mm	L2 mm	NL	CODE	PRIX PROMO € HT
1,00	3,00	55	10	7	271121	25,45
1,10	3,00	55	12	10	271122	25,45
1,20	3,00	55	12	10	271123	25,45
1,30	3,00	55	12	10	271124	25,45
1,40	3,00	55	12	10	271125	25,45
1,50	3,00	55	12	10	271126	25,45
1,60	3,00	55	16	13	271127	25,45
1,70	3,00	55	16	13	271128	25,45
1,80	3,00	55	16	13	271129	25,45
1,90	3,00	55	16	13	271130	25,45
2,00	3,00	57	21	16	271131	19,57
2,10	3,00	57	21	16	271132	25,45
2,20	3,00	57	21	16	271133	25,45
2,30	3,00	57	21	16	271134	25,45
2,40	3,00	57	21	16	271135	25,45
2,50	3,00	57	21	16	271136	25,45
2,60	3,00	57	21	19	271137	25,45
2,70	3,00	57	21	19	271138	25,45
2,80	3,00	57	21	19	271139	25,45
2,90	3,00	57	21	19	271140	25,45
3,00	6,00	66	28	23	271001	29,09
3,10	6,00	66	28	23	271002	29,09
3,20	6,00	66	28	23	271003	29,09
3,30	6,00	66	28	23	271004	29,09
3,40	6,00	66	28	23	271005	29,09
3,50	6,00	66	28	23	271006	29,09
3,60	6,00	66	28	23	271007	29,09
3,70	6,00	66	28	23	271008	29,09
3,80	6,00	74	36	29	271009	29,09
3,90	6,00	74	36	29	271010	29,09
4,00	6,00	74	36	29	271011	29,09
4,10	6,00	74	36	29	271012	29,09
4,20	6,00	74	36	29	271013	29,09
4,30	6,00	74	36	29	271014	29,09
4,40	6,00	74	36	29	271015	29,09
4,50	6,00	74	36	29	271016	29,09
4,60	6,00	74	36	29	271017	29,09
4,70	6,00	74	36	29	271018	29,09
4,80	6,00	82	44	35	271019	29,09
4,90	6,00	82	44	35	271020	29,09
5,00	6,00	82	44	35	271021	29,09
5,10	6,00	82	44	35	271022	29,09
5,20	6,00	82	44	35	271023	29,09
5,30	6,00	82	44	35	271024	29,09
5,40	6,00	82	44	35	271025	29,09
5,50	6,00	82	44	35	271026	29,09
5,60	6,00	82	44	35	271027	29,09
5,70	6,00	82	44	35	271028	29,09
5,80	6,00	82	44	35	271029	29,09
5,90	6,00	82	44	35	271030	29,09
6,00	6,00	82	44	35	271031	29,09
6,10	8,00	91	53	43	271032	35,62
6,20	8,00	91	53	43	271033	35,62
6,30	8,00	91	53	43	271034	35,62
6,40	8,00	91	53	43	271035	35,62
6,50	8,00	91	53	43	271036	35,62
6,60	8,00	91	53	43	271037	35,62
6,70	8,00	91	53	43	271038	35,62
6,80	8,00	91	53	43	271039	35,62
6,90	8,00	91	53	43	271040	35,62
7,00	8,00	91	53	43	271041	35,62
7,10	8,00	91	53	43	271042	35,62
7,20	8,00	91	53	43	271043	35,62
7,30	8,00	91	53	43	271044	35,62
7,40	8,00	91	53	43	271045	35,62
7,50	8,00	91	53	43	271046	35,62
7,60	8,00	91	53	43	271047	35,62
7,70	8,00	91	53	43	271048	35,62

D1M7 mm	D2H6 mm	L1 mm	L2 mm	NL	CODE	PRIX PROMO € HT
7,80	8,00	91	53	43	271049	35,62
7,90	8,00	91	53	43	271050	35,62
8,00	8,00	91	53	43	271051	35,62
8,10	10,00	103	61	43	271052	39,98
8,20	10,00	103	61	43	271053	39,98
8,30	10,00	103	61	43	271054	39,98
8,40	10,00	103	61	43	271055	39,98
8,50	10,00	103	61	43	271056	39,98
8,60	10,00	103	61	43	271057	39,98
8,70	10,00	103	61	43	271058	39,98
8,80	10,00	103	61	43	271059	39,98
8,90	10,00	103	61	43	271060	39,98
9,00	10,00	103	61	43	271061	39,98
9,10	10,00	103	61	43	271062	39,98
9,20	10,00	103	61	43	271063	39,98
9,30	10,00	103	61	43	271064	39,98
9,40	10,00	103	61	43	271065	39,98
9,50	10,00	103	61	43	271066	39,98
9,60	10,00	103	61	43	271067	39,98
9,70	10,00	103	61	43	271068	39,98
9,80	10,00	103	61	43	271069	39,98
9,90	10,00	103	61	43	271070	39,98
10,00	10,00	103	61	43	271071	39,98
10,10	12,00	118	71	56	271072	57,43
10,20	12,00	118	71	56	271073	57,43
10,30	12,00	118	71	56	271074	57,43
10,40	12,00	118	71	56	271075	57,43
10,50	12,00	118	71	56	271076	57,43
10,60	12,00	118	71	56	271077	57,43
10,70	12,00	118	71	56	271078	57,43
10,80	12,00	118	71	56	271079	57,43
10,90	12,00	118	71	56	271080	57,43
11,00	12,00	118	71	56	271081	57,43
11,10	12,00	118	71	56	271082	57,43
11,20	12,00	118	71	56	271083	57,43
11,30	12,00	118	71	56	271084	57,43
11,40	12,00	118	71	56	271085	57,43
11,50	12,00	118	71	56	271086	57,43
11,60	12,00	118	71	56	271087	57,43
11,70	12,00	118	71	56	271088	57,43
11,80	12,00	118	71	56	271089	57,43
11,90	12,00	118	71	56	271090	57,43
12,00	12,00	118	71	56	271091	57,43
12,30	14,00	124	77	60	271092	79,97
12,50	14,00	124	77	60	271093	79,97
12,80	14,00	124	77	60	271094	79,97
13,00	14,00	124	77	60	271095	79,97
13,50	14,00	124	77	60	271096	79,97
13,80	14,00	124	77	60	271097	79,97
14,00	14,00	124	77	60	271098	79,97
14,50	16,00	133	83	63	271099	98,16
14,80	16,00	133	83	63	271100	98,16
15,00	16,00	133	83	63	271101	98,16
15,50	16,00	133	83	63	271102	98,16
15,80	16,00	133	83	63	271103	98,16
16,00	16,00	133	83	63	271104	98,16
16,50	18,00	143	93	71	271105	116,33
16,80	18,00	143	93	71	271106	116,33
17,00	18,00	143	93	71	271107	116,33
17,50	18,00	143	93	71	271108	116,33
17,80	18,00	143	93	71	271109	116,33
18,00	18,00	143	93	71	271110	116,33
18,50	20,00	153	101	77	271111	145,40
19,00	20,00	153	101	77	271112	145,40
19,50	20,00	153	101	77	271113	145,40
20,00	20,00	153	101	77	271115	145,40

# FORETS CARBURE | SERIE 703

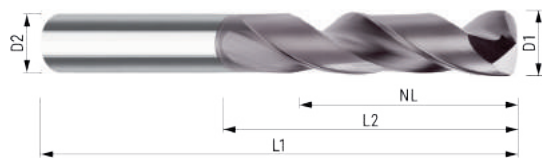

D1M7 mm	D2H6 mm	L1 mm	L2 mm	NL	CODE	PRIX PROMO € HT
3,00	6,00	62	20	14	270430	23,36
3,10	6,00	62	20	14	270431	23,36
3,20	6,00	62	20	14	270432	23,36
3,30	6,00	62	20	14	270433	23,36
3,40	6,00	62	20	14	270434	23,36
3,50	6,00	62	20	14	270435	23,36
3,60	6,00	62	20	14	270436	23,36
3,70	6,00	62	20	14	270437	23,36
3,80	6,00	66	24	17	270438	23,36
3,90	6,00	66	24	17	270439	23,36
4,00	6,00	66	24	17	270440	23,36
4,10	6,00	66	24	17	270441	23,36
4,20	6,00	66	24	17	270442	23,36
4,30	6,00	66	24	17	270443	23,36
4,40	6,00	66	24	17	270444	23,36
4,50	6,00	66	24	17	270445	23,36
4,60	6,00	66	24	17	270446	23,36
4,70	6,00	66	24	17	270447	23,36
4,80	6,00	66	28	20	270448	23,36
4,90	6,00	66	28	20	270449	23,36
5,00	6,00	66	28	20	270450	23,36
5,10	6,00	66	28	20	270451	23,36
5,20	6,00	66	28	20	270452	23,36
5,30	6,00	66	28	20	270453	23,36
5,40	6,00	66	28	20	270454	23,36
5,50	6,00	66	28	20	270455	23,36
5,60	6,00	66	28	20	270456	23,36
5,70	6,00	66	28	20	270457	23,36
5,80	6,00	66	28	20	270458	23,36
5,90	6,00	66	28	20	270459	23,36
6,00	6,00	66	28	20	270460	23,36
6,10	8,00	79	34	24	270461	32,91
6,20	8,00	79	34	24	270462	32,91
6,30	8,00	79	34	24	270463	32,91
6,40	8,00	79	34	24	270464	32,91
6,50	8,00	79	34	24	270465	32,91
6,60	8,00	79	34	24	270466	32,91
6,70	8,00	79	34	24	270467	32,91
6,80	8,00	79	34	24	270468	32,91
6,90	8,00	79	34	24	270469	32,91
7,00	8,00	79	34	24	270470	32,91
7,10	8,00	79	51	29	270471	32,91
7,20	8,00	79	51	29	270472	32,91
7,30	8,00	79	51	29	270473	32,91
7,40	8,00	79	51	29	270474	32,91
7,50	8,00	79	51	29	270475	32,91
7,60	8,00	79	51	29	270476	32,91
7,70	8,00	79	51	29	270477	32,91
7,80	8,00	79	51	29	270478	32,91
7,90	8,00	79	51	29	270479	32,91
8,00	8,00	79	51	29	270480	32,91
8,10	10,00	89	47	35	270481	40,52
8,20	10,00	89	47	35	270482	40,52
8,30	10,00	89	47	35	270483	40,52
8,40	10,00	89	47	35	270484	40,52
8,50	10,00	89	47	35	270485	40,52
8,60	10,00	89	47	35	270486	40,52
8,70	10,00	89	47	35	270487	40,52
8,80	10,00	89	47	35	270488	40,52
8,90	10,00	89	47	35	270489	40,52
9,00	10,00	89	47	35	270490	40,52

D1M7 mm	D2H6 mm	L1 mm	L2 mm	NL	CODE	PRIX PROMO € HT
9,10	10,00	89	47	35	270491	40,52
9,20	10,00	89	47	35	270492	40,52
9,30	10,00	89	47	35	270493	40,52
9,40	10,00	89	47	35	270494	40,52
9,50	10,00	89	47	35	270495	40,52
9,60	10,00	89	47	35	270496	40,52
9,70	10,00	89	47	35	270497	40,52
9,80	10,00	89	47	35	270498	40,52
9,90	10,00	89	47	35	270499	40,52
10,00	10,00	89	47	35	270500	40,52
10,10	12,00	102	55	40	270501	57,34
10,20	12,00	102	55	40	270502	57,34
10,30	12,00	102	55	40	270503	57,34
10,40	12,00	102	55	40	270504	57,34
10,50	12,00	102	55	40	270505	57,34
10,60	12,00	102	55	40	270506	57,34
10,70	12,00	102	55	40	270507	57,34
10,80	12,00	102	55	40	270508	57,34
10,90	12,00	102	55	40	270509	57,34
11,00	12,00	102	55	40	270510	57,34
11,10	12,00	102	55	40	270511	57,34
11,20	12,00	102	55	40	270512	57,34
11,30	12,00	102	55	40	270513	57,34
11,40	12,00	102	55	40	270514	57,34
11,50	12,00	102	55	40	270515	57,34
11,60	12,00	102	55	40	270516	57,34
11,70	12,00	102	55	40	270517	57,34
11,80	12,00	102	55	40	270518	57,34
11,90	12,00	102	55	40	270519	57,34
12,00	12,00	102	55	40	270520	57,34
12,20	12,00	102	55	40	270521	80,41
12,30	14,00	107	60	43	270522	80,41
12,50	14,00	107	60	43	270523	80,41
12,80	14,00	107	60	43	270524	80,41
13,00	14,00	107	60	43	270525	97,86
13,50	14,00	107	60	43	270526	97,86
13,80	14,00	107	60	43	270527	97,86
14,00	14,00	107	60	43	270528	97,86
14,50	16,00	115	65	45	270529	132,17
14,80	16,00	115	65	45	270530	132,17
15,00	16,00	115	65	45	270531	132,17
15,50	16,00	115	65	45	270532	132,17
15,80	16,00	115	65	45	270533	170,81
16,00	16,00	115	65	45	270534	170,81
16,50	18,00	123	73	51	270535	170,81
16,70	18,00	123	73	51	270536	170,81
17,00	18,00	123	73	51	270537	80,41
17,50	18,00	123	73	51	270538	80,41
17,80	18,00	123	73	51	270539	80,41
18,00	18,00	123	73	51	270541	97,86
18,50	20,00	131	79	55	270542	97,86
19,00	20,00	131	79	55	270543	132,17
19,50	20,00	131	79	55	270544	132,17
19,80	20,00	131	79	55	270545	170,81

# FORETS CARBURE | SERIE 705

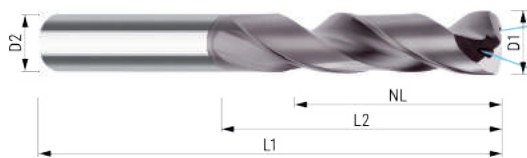

D1M7 mm	D2H6 mm	L1 mm	L2 mm	NL	CODE	PRIX PROMO € HT
3,00	6,00	66	28	23	270061	39,86
3,10	6,00	66	28	23	270062	39,86
3,20	6,00	66	28	23	270063	39,86
3,30	6,00	66	28	23	270064	39,86
3,40	6,00	66	28	23	270065	39,86
3,50	6,00	66	28	23	270066	39,86
3,60	6,00	66	28	23	270067	39,86
3,70	6,00	66	28	23	270068	39,86
3,80	6,00	74	36	29	270069	39,86
3,90	6,00	74	36	29	270070	39,86
4,00	6,00	74	36	29	270071	39,86
4,10	6,00	74	36	29	270072	39,86
4,20	6,00	74	36	29	270073	39,86
4,30	6,00	74	36	29	270074	39,86
4,40	6,00	74	36	29	270075	39,86
4,50	6,00	74	36	29	270076	39,86
4,60	6,00	74	36	29	270077	39,86
4,70	6,00	74	36	29	270078	39,86
4,80	6,00	82	44	35	270079	39,86
4,90	6,00	82	44	35	270080	39,86
5,00	6,00	82	44	35	270081	39,86
5,10	6,00	82	44	35	270082	39,86
5,20	6,00	82	44	35	270083	39,86
5,30	6,00	82	44	35	270084	39,86
5,40	6,00	82	44	35	270085	39,86
5,50	6,00	82	44	35	270086	39,86
5,60	6,00	82	44	35	270087	39,86
5,70	6,00	82	44	35	270088	39,86
5,80	6,00	82	44	35	270089	39,86
5,90	6,00	82	44	35	270090	39,86
6,00	6,00	82	44	35	270091	39,86
6,10	8,00	91	53	43	270092	46,50
6,20	8,00	91	53	43	270093	46,50
6,30	8,00	91	53	43	270094	46,50
6,40	8,00	91	53	43	270095	46,50
6,50	8,00	91	53	43	270096	46,50
6,60	8,00	91	53	43	270097	46,50
6,70	8,00	91	53	43	270098	46,50
6,80	8,00	91	53	43	270099	46,50
6,90	8,00	91	53	43	270100	46,50
7,00	8,00	91	53	43	270101	46,50
7,10	8,00	91	53	43	270102	46,50
7,20	8,00	91	53	43	270103	46,50
7,30	8,00	91	53	43	270104	46,50
7,40	8,00	91	53	43	270105	46,50
7,50	8,00	91	53	43	270106	46,50
7,60	8,00	91	53	43	270107	46,50
7,70	8,00	91	53	43	270108	46,50
7,80	8,00	91	53	43	270109	46,50
7,90	8,00	91	53	43	270110	46,50
8,00	8,00	91	53	43	270111	46,50
8,10	8,00	91	53	43	270112	46,50
8,20	8,00	91	53	43	270113	46,50
8,10	10,00	103	61	49	270114	53,14
8,20	10,00	103	61	49	270115	53,14
8,30	10,00	103	61	49	270116	53,14
8,40	10,00	103	61	49	270117	53,14
8,50	10,00	103	61	49	270118	53,14
8,60	10,00	103	61	49	270119	53,14
8,70	10,00	103	61	49	270120	53,14
8,80	10,00	103	61	49	270121	53,14
8,90	10,00	103	61	49	270122	53,14

D1M7 mm	D2H6 mm	L1 mm	L2 mm	NL	CODE	PRIX PROMO € HT
9,00	10,00	103	61	49	270123	53,14
9,10	10,00	103	61	49	270124	53,14
9,20	10,00	103	61	49	270125	53,14
9,30	10,00	103	61	49	270126	53,14
9,40	10,00	103	61	49	270127	53,14
9,50	10,00	103	61	49	270128	53,14
9,60	10,00	103	61	49	270129	53,14
9,70	10,00	103	61	49	270130	53,14
9,80	10,00	103	61	49	270131	53,14
9,90	10,00	103	61	49	270132	53,14
10,00	10,00	103	61	49	270133	53,14
10,10	12,00	118	71	56	270134	53,14
10,20	12,00	118	71	56	270135	53,14
10,30	12,00	118	71	56	270136	53,14
10,40	12,00	118	71	56	270137	75,72
10,50	12,00	118	71	56	270138	75,72
10,60	12,00	118	71	56	270139	75,72
10,70	12,00	118	71	56	270140	75,72
10,80	12,00	118	71	56	270141	75,72
10,90	12,00	118	71	56	270142	75,72
11,00	12,00	118	71	56	270143	75,72
11,10	12,00	118	71	56	270144	75,72
11,20	12,00	118	71	56	270145	75,72
11,30	12,00	118	71	56	270146	75,72
11,40	12,00	118	71	56	270147	75,72
11,50	12,00	118	71	56	270148	75,72
11,60	12,00	118	71	56	270149	75,72
11,70	12,00	118	71	56	270150	75,72
11,80	12,00	118	71	56	270151	75,72
11,90	12,00	118	71	56	270152	75,72
12,00	12,00	118	71	56	270153	75,72
12,50	14,00	124	77	60	270154	75,72
13,00	14,00	124	77	60	270155	96,34
13,50	14,00	124	77	60	270156	96,34
14,00	14,00	124	77	60	270157	96,34
14,50	16,00	133	83	63	270158	118,91
15,00	16,00	133	83	63	270159	118,91
15,50	16,00	133	83	63	270160	118,91
16,00	16,00	133	83	63	270161	118,91
16,50	18,00	143	93	71	270162	186,02
17,00	18,00	143	93	71	270163	186,02
17,50	18,00	143	93	71	270164	186,02
18,00	18,00	143	93	71	270165	186,02
18,50	20,00	153	101	77	270166	198,64
19,00	20,00	153	101	77	270167	198,64
19,50	20,00	153	101	77	270168	198,64
20,00	20,00	153	101	77	270169	198,64

# FORETS CARBURE | SERIE 708



D1M7 mm	D2H6 mm	L1 mm	L2 mm	NL	CODE	PRIX PROMO € HT
1,00	3,00	55	11	9,00	270190	29,52
1,10	3,00	55	17	13,50	270191	29,52
1,20	3,00	55	17	13,50	270192	29,52
1,30	3,00	55	17	13,50	270193	29,52
1,40	3,00	55	17	13,50	270194	29,52
1,50	3,00	55	17	13,50	270195	29,52
1,60	3,00	65	22	17,50	270196	29,52
1,70	3,00	65	22	17,50	270197	29,52
1,80	3,00	65	22	17,50	270198	29,52
1,90	3,00	65	22	17,50	270199	29,52
2,00	3,00	74	28	22,50	270411	30,71
2,10	3,00	74	28	22,50	270412	30,71
2,20	3,00	74	28	22,50	270413	30,71
2,30	3,00	74	28	22,50	270414	30,71
2,40	3,00	74	28	22,50	270415	30,71
2,50	3,00	74	28	22,50	270416	30,71
2,60	3,00	81	32	22,50	270417	31,69
2,70	3,00	81	32	22,50	270418	31,69
2,80	3,00	81	32	22,50	270419	31,69
2,90	3,00	81	32	22,50	270420	31,69
3,00	6,00	72	34	27,00	270670	38,72
3,10	6,00	72	34	27,00	270671	38,72
3,20	6,00	72	34	27,00	270672	38,72
3,30	6,00	72	34	27,00	270673	38,72
3,40	6,00	72	34	27,00	270674	38,72
3,50	6,00	72	34	27,00	270675	38,72
3,60	6,00	72	34	27,00	270676	39,45
3,70	6,00	72	34	27,00	270677	39,45
3,80	6,00	86	43	35,00	270678	40,86
3,90	6,00	86	43	35,00	270679	40,86
4,00	6,00	86	43	35,00	270680	41,59
4,10	6,00	86	43	35,00	270681	43,00
4,20	6,00	86	43	35,00	270682	43,00
4,30	6,00	86	43	35,00	270683	43,00
4,40	6,00	86	43	35,00	270684	43,00
4,50	6,00	86	43	35,00	270685	44,43
4,60	6,00	86	43	35,00	270686	47,31
4,70	6,00	86	43	35,00	270687	56,47
4,80	6,00	95	57	45,00	270688	47,31
4,90	6,00	95	57	45,00	270689	48,74
5,00	6,00	95	57	45,00	270690	48,74
5,10	6,00	95	57	45,00	270691	48,74
5,20	6,00	95	57	45,00	270692	48,74
5,30	6,00	95	57	45,00	270693	48,74
5,40	6,00	95	57	45,00	270694	48,74
5,50	6,00	95	57	45,00	270695	48,74
5,60	6,00	95	57	45,00	270696	48,74
5,70	6,00	95	57	45,00	270697	48,74
5,80	6,00	95	57	45,00	270698	49,47
5,90	6,00	95	57	45,00	270699	52,33
6,00	6,00	95	57	45,00	270700	52,33
6,10	8,00	114	76	52,00	270701	67,40
6,20	8,00	114	76	52,00	270702	70,28
6,30	8,00	114	76	52,00	270703	70,28
6,40	8,00	114	76	52,00	270704	70,28
6,50	8,00	114	76	52,00	270705	70,97
6,60	8,00	114	76	52,00	270706	70,97
6,70	8,00	114	76	52,00	270707	70,97
6,80	8,00	114	76	52,00	270708	70,97
6,90	8,00	114	76	52,00	270709	70,97

D1M7 mm	D2H6 mm	L1 mm	L2 mm	NL	CODE	PRIX PROMO € HT
7,00	8,00	114	76	60,00	270710	70,97
7,10	8,00	114	76	60,00	270711	70,97
7,20	8,00	114	76	60,00	270712	70,97
7,30	8,00	114	76	60,00	270713	70,97
7,40	8,00	114	76	60,00	270714	72,41
7,50	8,00	114	76	60,00	270715	72,41
7,60	8,00	114	76	60,00	270716	76,69
7,70	8,00	114	76	60,00	270717	76,69
7,80	8,00	114	76	60,00	270718	76,69
7,90	8,00	114	76	60,00	270719	76,69
8,00	8,00	114	76	60,00	270720	75,26
8,10	10,00	142	95	68,00	270721	95,36
8,20	10,00	142	95	68,00	270722	95,36
8,30	10,00	142	95	68,00	270723	95,36
8,40	10,00	142	95	68,00	270724	95,36
8,50	10,00	142	95	68,00	270725	95,36
8,60	10,00	142	95	68,00	270726	95,36
8,70	10,00	142	95	68,00	270727	95,36
8,80	10,00	142	95	68,00	270728	95,36
8,90	10,00	142	95	68,00	270729	95,36
9,00	10,00	142	95	68,00	270730	96,09
9,10	10,00	142	95	76,00	270731	96,09
9,20	10,00	142	95	76,00	270732	96,09
9,30	10,00	142	95	76,00	270733	96,09
9,40	10,00	142	95	76,00	270734	96,09
9,50	10,00	142	95	76,00	270735	96,79
9,60	10,00	142	95	76,00	270736	96,79
9,70	10,00	142	95	76,00	270737	97,52
9,80	10,00	142	95	76,00	270738	97,52
9,90	10,00	142	95	76,00	270739	97,52
10,00	10,00	142	95	76,00	270740	101,07
10,10	12,00	162	114	90,00	270741	127,60
10,20	12,00	162	114	90,00	270742	127,60
10,30	12,00	162	114	90,00	270743	128,33
10,40	12,00	162	114	90,00	270744	128,33
10,50	12,00	162	114	90,00	270745	129,03
10,60	12,00	162	114	90,00	270746	129,03
10,70	12,00	162	114	90,00	270747	129,76
10,80	12,00	162	114	90,00	270748	129,76
10,90	12,00	162	114	90,00	270749	129,76
11,00	12,00	162	114	90,00	270750	130,48
11,10	12,00	162	114	90,00	270751	130,48
11,20	12,00	162	114	90,00	270752	131,19
11,30	12,00	162	114	90,00	270753	131,19
11,40	12,00	162	114	90,00	270754	131,19
11,50	12,00	162	114	90,00	270755	131,91
11,60	12,00	162	114	90,00	270756	131,91
11,70	12,00	162	114	90,00	270757	132,62
11,80	12,00	162	114	90,00	270758	132,62
11,90	12,00	162	114	90,00	270759	132,62
12,00	12,00	162	114	90,00	270760	133,33
12,50	14,00	184	133	106,00	270421	188,12
12,80	14,00	184	133	106,00	270422	188,12
13,00	14,00	184	133	106,00	270423	188,12
13,50	14,00	184	133	106,00	270424	188,12
14,00	14,00	184	133	106,00	270425	188,12
14,50	16,00	203	152	122,00	270426	253,34
15,00	16,00	203	152	122,00	270427	253,34
15,50	16,00	203	152	122,00	270428	253,34
16,00	16,00	203	152	122,00	270429	253,34

# FORETS CARBURE | SERIE LONGUE DEEPMAX 908



D1 mm	D2H6 mm	L1 mm	L2 mm	CODE	PRIX PROMO € HT
1,00	3	75	18,20	272275	101,00
1,10	3	75	20,20	272276	101,00
1,20	3	75	24,20	272277	101,00
1,30	3	75	24,20	272278	101,00
1,40	3	75	27,20	272279	101,00
1,50	3	75	27,20	272280	101,00
1,60	3	75	30,20	272281	101,00
1,70	3	75	30,20	272282	101,00
1,80	3	75	35,20	272283	101,00
1,90	3	75	35,20	272284	101,00
2,00	4	80	35,50	272285	107,00
2,10	4	80	40,50	272286	107,00
2,20	4	80	40,50	272287	107,00
2,30	4	80	40,50	272288	107,00
2,40	4	90	45,50	272289	107,00
2,50	4	90	45,50	272290	107,00
2,60	4	90	48,50	272291	107,00
2,70	4	90	48,50	272292	107,00
2,80	4	90	50,50	272293	107,00
2,90	4	90	50,50	272294	107,00
3,00	6	100	55,50	272295	127,00
3,10	6	100	55,50	272296	127,00
3,20	6	100	60,50	272297	127,00
3,30	6	100	60,50	272298	127,00
3,40	6	100	60,50	272299	127,00
3,50	6	108	65,50	272300	127,00
3,60	6	108	65,50	272301	127,00
3,70	6	108	70,50	272302	127,00
3,80	6	108	70,50	272303	127,00
3,90	6	108	70,70	272304	127,00
4,00	6	120	75,50	272305	140,00
4,10	6	120	75,50	272306	140,00
4,20	6	120	75,50	272307	140,00
4,30	6	120	80,50	272308	140,00
4,40	6	120	80,50	272309	140,00
4,50	6	120	80,50	272310	140,00
4,60	6	125	85,50	272311	140,00
4,70	6	125	85,50	272312	140,00
4,80	6	140	90,50	272313	140,00
4,90	6	140	90,50	272314	140,00
5,00	6	140	90,50	272315	140,00
5,10	6	140	95,50	272316	162,00
5,20	6	140	95,50	272317	162,00
5,30	6	140	95,50	272318	162,00
5,40	6	140	95,50	272319	162,00
5,50	6	150	100,50	272320	162,00
5,60	6	150	100,50	272321	162,00
5,70	6	150	100,50	272322	162,00
5,80	6	150	100,50	272323	162,00
5,90	6	150	100,50	272324	162,00
6,00	6	150	100,50	272325	162,00
6,10	8	148	108,00	272326	165,00
6,20	8	148	108,00	272327	165,00

D1 mm	D2 mm	L1 mm	L2 mm	CODE	PRIX PROMO € HT
7,00	8	170	131,00	272335	165,00
7,50	8	170	131,00	272336	165,00
7,80	8	180	141,00	272337	171,00
8,00	8	180	141,00	272338	171,00
8,50	10	198	155,00	272339	171,00
8,80	10	208	165,00	272340	171,00
9,00	10	208	165,00	272341	171,00
9,50	10	208	165,00	272342	171,00
9,80	10	208	165,00	272343	171,00
10,00	10	218	175,00	272344	171,00
10,20	12	235	187,00	272345	216,00
10,50	12	245	197,00	272346	216,00
10,80	12	245	197,00	272347	216,00
11,00	12	245	197,00	272348	216,00
11,20	12	245	197,00	272349	216,00
11,50	12	245	197,00	272350	216,00
11,80	12	255	207,00	272351	216,00
12,00	12	255	207,00	272352	216,00

# FORETS CARBURE | SERIE LONGUE DEEPMAX 909



D1 mm	D2H6 mm	L1 mm	L2 mm	CODE	PRIX PROMO € HT
2,00	4	95	45,50	272353	107,00
2,10	4	95	50,50	272354	107,00
2,20	4	95	50,50	272355	107,00
2,30	4	95	55,50	272356	107,00
2,40	4	95	55,50	272357	107,00
2,50	4	108	60,50	272358	107,00
2,60	4	108	60,50	272359	107,00
2,70	4	108	65,50	272360	107,00
2,80	4	108	65,50	272361	107,00
2,90	4	112	68,50	272362	107,00
3,00	6	112	68,50	272363	159,00
3,20	6	120	75,50	272364	159,00
3,30	6	120	75,50	272365	159,00
3,50	6	130	80,50	272366	159,00
3,80	6	140	90,50	272367	159,00
4,00	6	140	95,50	272368	159,00
4,20	6	140	95,50	272369	159,00
4,50	6	160	110,50	272370	171,00
4,60	6	160	110,50	272371	171,00
4,80	6	160	115,50	272372	183,00
5,00	6	160	115,50	272373	186,00
5,50	6	185	140,50	272374	192,00
5,80	6	185	140,50	272375	192,00
6,00	6	185	140,50	272376	192,00
6,50	8	190	150,00	272377	220,00
6,80	8	200	160,00	272378	220,00
7,00	8	210	170,00	272379	220,00
7,50	8	210	170,00	272380	220,00
7,80	8	230	190,00	272381	234,00
8,00	8	230	190,00	272382	234,00
8,50	10	240	196,00	272383	303,00
8,80	10	260	216,00	272384	303,00
9,00	10	260	216,00	272385	303,00
9,80	10	280	236,00	272386	310,00
10,00	10	280	236,00	272387	310,00
10,20	12	290	241,00	272388	395,00
10,80	12	315	266,00	272389	395,00
11,80	12	315	266,00	272390	395,00
12,00	12	315	266,00	272391	395,00

# FORETS CARBURE | SERIE LONGUE DEEPMAX 911



D1 mm	D2H6 mm	L1 mm	L2 mm	CODE	PRIX PROMO € HT
2,00	4	105	65,50	272421	120,00
2,20	4	115	75,50	272422	120,00
2,30	4	115	75,50	272423	120,00
2,40	4	130	85,50	272424	120,00
2,50	4	130	85,50	272425	120,00
2,70	4	140	95,50	272426	120,00
2,80	4	140	95,50	272427	120,00
2,90	4	140	95,50	272428	120,00
3,00	6	150	105,50	272429	225,00
3,10	6	150	105,50	272430	225,00
3,30	6	160	115,50	272431	234,00
3,50	6	160	115,50	272432	234,00
3,80	6	175	125,50	272433	234,00
4,00	6	185	135,50	272434	240,00
4,20	6	185	135,50	272435	240,00
4,50	6	195	145,50	272436	240,00
4,60	6	205	155,50	272437	240,00
4,80	6	210	165,50	272438	250,00
5,00	6	210	165,50	272439	250,00
5,50	6	240	180,50	272440	258,00
5,80	6	240	190,50	272441	258,00
6,00	6	240	190,50	272442	258,00
6,50	8	260	222,00	272443	282,00
6,80	8	260	222,00	272444	282,00
7,00	8	270	232,00	272445	305,00
7,50	8	290	252,00	272446	305,00
7,80	8	300	262,00	272447	305,00
8,00	8	305	267,00	272448	305,00
8,50	10	320	278,00	272449	422,00
8,80	10	340	298,00	272450	422,00
9,00	10	340	298,00	272451	422,00
9,50	10	360	318,00	272452	422,00
9,80	10	380	338,00	272453	422,00
10,00	10	380	338,00	272454	422,00

# FORETS CARBURE | SERIE LONGUE DEEPMAX 910



D1 mm	D2H6 mm	L1 mm	L2 mm	CODE	PRIX PROMO € HT
3,00	6	130	85,50	272392	197,00
3,20	6	140	95,50	272393	197,00
3,30	6	140	95,50	272394	197,00
3,50	6	150	100,50	272395	197,00
3,80	6	150	105,50	272396	203,00
4,00	6	160	110,50	272397	203,00
4,20	6	170	120,50	272398	203,00
4,50	6	180	130,50	272399	210,00
4,80	6	190	140,50	272400	218,00
5,00	6	190	140,50	272401	222,00
5,50	6	210	160,50	272402	222,00
5,80	6	210	160,50	272403	222,00
6,00	6	220	170,50	272404	222,00
6,50	8	230	191,00	272405	250,00
6,80	8	230	191,00	272406	250,00
7,00	8	240	201,00	272407	250,00
7,50	8	250	214,00	272408	250,00
7,80	8	260	224,00	272409	263,00
8,00	8	260	224,00	272410	263,00
8,50	10	280	237,00	272411	332,00
8,80	10	290	247,00	272412	332,00
9,00	10	290	247,00	272413	332,00
9,50	10	310	267,00	272414	346,00
9,80	10	310	267,00	272415	346,00
10,00	10	310	267,00	272416	346,00
10,20	12	340	295,00	272417	525,00
10,80	12	350	302,00	272418	525,00
11,80	12	375	327,00	272419	525,00
12,00	12	375	327,00	272420	525,00

## COFFRET FORETS | HSS - CO5



Désignation	Code	Prix promo € HT
COFFRET HSS TYPE N (91 PCS) 1 - 10 PAR 0,1   REF. 1406-1010	026960	145,00
COFFRET CO5 TYPE N (91 PCS) 1-10 PAR 0,1   REF. 1406-1016	026965	230,00

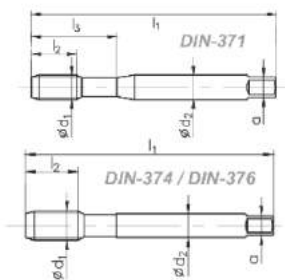

ISO	Nr. mat. No. mat.	Vc [m/min]
P	1+8 10+11	20-40
	9 13+14	5-15
M	1+3	5-15
K	1+6	10-30
N	1+10	10-30
S	1+3 6	5-15

C-R40-TN2



< 2,5 D

B-TN2



< 3 D

**TYPE DE MATÉRIEL  
REVÊTEMENT  
ENTRÉE  
GOUJURE**

M	P	L1	L2	L2 R40	L3	D2	a		INDEX	HSSE TIALN + TiN C / 2-3F HÉLICOÏDALE 45° C2-513X01 CODE	HSSE TIALN + TiN B / 4-5F DROITE C2-113X01 CODE
<b>PAS MÉTRIQUE</b>										<b>DIN-371</b>	
M3	0,50	56	10	5	18	3,5	2,7	2,50	0030	045751 8,94	045362 8,25
M4	0,70	63	12	7	21	4,5	3,4	3,30	0040	045753 9,09	045364 8,09
M5	0,80	70	14	8	25	6,00	4,90	4,20	0050	045756 9,79	045367 9,07
M6	1,00	80	18	10	35	6,00	4,90	5,00	0060	045758 10,13	045369 9,38
M8	1,25	90	20	13	35	8,00	6,20	6,80	0080	045761 12,10	045372 11,22
M10	1,50	100	20	15	39	10,00	8,00	8,50	0100	045765 15,83	045376 14,72
<b>PAS FIN</b>										<b>DIN-371</b>	
M8x1	1,00	90	20	10	-	6,00	4,90	7,00	0083	045492 14,99	045486 13,19
M10x1	1,00	90	20	13	-	7,00	5,50	9,00	0103	045493 18,32	045487 16,18
M10x1,25	1,25	100	20	15	-	7,00	5,50	8,80	0104	045494 20,78	045488 18,35
<b>PAS MÉTRIQUE</b>										<b>DIN-376</b>	
M12	1,75	110	24	18	-	9,00	7,00	10,20	0120	045778 22,10	045389 20,49
M14	2,00	110	25	20	-	11,00	9,00	12,00	0140	045782 29,27	045393 27,09
M16	2,00	110	32	20	-	12,00	9,00	14,00	0160	045787 31,68	045399 29,39
M18	2,50	125	32	25	-	14,00	11,00	15,50	0180	045790 43,09	045402 39,89
M20	2,50	140	32	25	-	16,00	12,00	17,50	0200	045794 46,98	045406 43,56
M22	2,50	140	32	25	-	18,00	14,50	19,50	0220	045798 63,78	045410 58,94
M24	3,00	160	38	30	-	18,00	4,50	21,00	0240	045802 64,40	045414 59,00
M27	3,00	160	38	30	-	20,00	16,00	24,00	0270	045808 82,60	045420 76,37
M30	3,50	180	40	35	-	22,00	18,00	26,00	0300	045813 96,97	045425 89,96
M33	3,50	180	45	35	-	25,00	20,00	29,50	0330	045818 132,24	045430 129,10
M36	4,00	200	50	40	-	28,00	22,00	32,00	0360	045823 187,92	045435 165,58
<b>PAS FIN</b>										<b>DIN-374</b>	
M12x1,5	1,50	100	20	5	-	9,00	7,00	10,50	0125	045495 25,58	045489 22,56
M14x1,5	1,50	100	20	7	-	11,00	9,00	12,00	0145	045496 34,05	045490 31,43
M16x1,5	1,50	100	20	8	-	12,00	9,00	14,00	0162	045497 35,54	045491 32,88

# TARAUDS MACHINE | MASTER TAP M

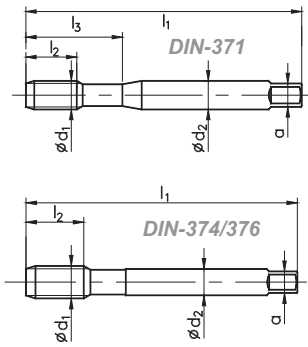

ISO	Nr. mat.	No. mat.	Vc [m/min]
P	1+8	10+11	20-40
	9	13+14	5-15
M	1+3		5-15
K	1+6		10-30
N	1+10		10-30
S	1+3	6	5-15



< 3 D



< 2,5 D

## TOLÉRANCE REVÊTEMENT ENTRÉE GOUJURE



M	P	L1	L2	L3	D2	a
2	0,4	45	8	12	2,8	2,1 1,6
2,5	0,45	50	5	14	2,8	2,1 2,05

## ISO2 (6H) HL

B = 4 - 5 FILETS  
DROITE

C4-118M01

CODE PRIX PROMO

DIN-371

045711	15,53
045712	15,53

## ISO2 (6H) HL

C = 2 - 3 FILETS  
HÉLICOÏDALE 45°

C4-528M01

CODE PRIX PROMO

DIN-371

045719	15,53
045720	15,53

## TOLÉRANCE

3	0,50	56	5	18	3,5	2,1 2,50
4	0,70	63	7	21	4,5	3,4 3,30
5	0,80	70	8	25	6	4,9 4,20
6	1,00	80	10	30	6	4,9 5,00
8	1,25	90	13	35	8	6,2 6,80
10	1,50	100	15	39	10	8 8,50

## 6HX

045713	12,02
045714	12,65
045715	13,75
045716	14,25
045717	17,12
045718	22,50

## 6HX

045721	12,02
045722	12,65
045723	13,75
045724	14,25
045725	17,12
045726	22,50

D4-118M31

DIN-376

045727	33,16
045728	43,46
045729	46,75

D4-528M01

DIN-376

045730	33,16
045731	43,46
045732	46,75

# TARAUDS MACHINE | MASTER TAP UNC



HSSE  
PM

HL

DIN  
371

DIN  
376

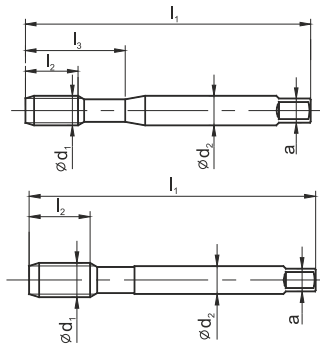

B-HL



< 3 D

C-R45-HL



< 2,5 D

TYPE DE TROU  
QUALITÉ  
REVÊTEMENT  
ENTRÉE  
GOUJURE

UNC	D1	1"/P	P	L1	L2	L3	D2	a		INDEX
No 2-56	2,184	56	0,455	45	10	13	2,8	2,1	1,85	4102
No 4-40	2,844	40	0,635	56	5	18	3,5	2,7	2,35	4104
No 5-40	3,175	40	0,635	56	7	8	3,5	2,7	2,65	4105
No 6-32	3,505	32	0,794	56	6	20	4,0	3,0	2,85	4106
No 8-32	4,165	32	0,794	63	7	21	4,5	3,4	3,50	4108
No 10-24	4,826	24	1,058	70	8	25	6,0	4,9	3,90	4110
No 12-24	5,486	24	1,058	80	10	30	6,0	4,9	4,50	4112
1/4-20	6,350	20	1,270	80	13	30	7,0	5,5	5,10	4127
5/16-18	7,938	18	1,411	90	13	35	8,0	6,0	6,60	4128
3/8-16	9,525	16	1,588	100	15	39	10,0	8,0	8,00	4129



HSSE-PM  
HL  
B / 4-5P  
DROITE

C4-118M01  
CODE PRIX PROMO  
DIN-371



HSSE-PM  
HL  
C / 2-3P  
HÉLICOÏDALE 45°

C4-528M01  
CODE PRIX PROMO  
DIN-371

7/16-14	11,112	14	1,814	100	15	-	8,0	6,2	9,40	4130
1/2-13	12,700	13	1,954	110	18	-	9,0	7,0	10,80	4131
9/16-12	14,288	12	2,117	110	20	-	11,0	9,0	12,20	4132
5/8-11	15,875	11	2,309	110	22	-	12,0	9,0	13,50	4133

D4-118M31  
DIN-376

044063	32,57
044064	45,78
044065	45,23
044066	41,85

D4-528M01  
DIN-376

044077	35,24
044078	49,08
044079	48,97
044080	45,19

# TARAUDS MACHINE | MASTER TAP UNF



HSSE  
PM

HL

DIN  
371

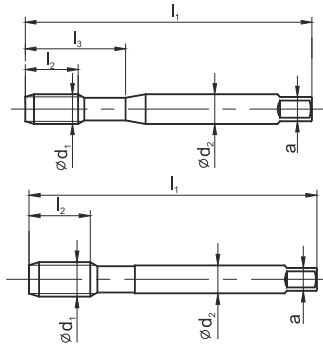

B-HL



< 3 D

C-R45-HL



< 2,5 D



HSSE-PM  
HL  
B / 4-5P  
DROITE

C4-118M01

CODE PRIX PROMO

DIN-371



HSSE-PM  
HL  
C / 2-3P  
HÉLICOÏDALE 45°

C4-528M01

CODE PRIX PROMO

DIN-371

TYPE DE TROU  
QUALITÉ  
REVÊTEMENT  
ENTRÉE  
GOUJURE

UNF	D1	1"/P	P	L1	L2	L3	D2	a		INDEX	C4-118M01		C4-528M01	
											CODE	PRIX PROMO	CODE	PRIX PROMO
No 4-48	2,844	48	0,529	56	5	18	3,50	2,7	2,40	4204	044081	19,10	044094	21,79
No 5-44	3,175	44	0,557	56	7	18	3,50	2,7	2,70	4205	044082	18,42	044095	21,29
No 6-40	3,505	40	0,635	56	6	20	4,00	3,0	2,95	4206	044083	18,42	044096	21,29
No 8-36	4,185	36	0,705	63	7	21	4,50	3,4	3,50	4208	044084	16,53	044097	20,02
No 10-32	4,826	32	0,794	70	8	25	6,00	4,9	4,10	4210	044085	21,83	044098	23,74
No 12-28	5,486	28	0,907	80	10	30	6,00	4,9	4,60	4212	044086	19,24	044099	20,89
1/4-28	6,350	28	0,907	80	10	30	7,00	5,5	5,50	4227	044087	19,88	044100	26,52
5/16-24	7,938	24	1,058	90	13	35	8,00	6,0	6,90	4228	044088	22,95	044101	26,52
3/8-24	9,525	24	1,058	100	15	39	10,00	8,0	8,50	4229	044089	29,56	044102	33,25
											D4-118M01		D4-528M01	
											CODE	PRIX PROMO	CODE	PRIX PROMO
											DIN-376		DIN-376	
7/16-20	11,112	20	1,270	100	15	-	8,00	6,2	9,90	4230	044090	36,48	044103	39,46
1/2-20	12,700	20	1,270	110	15	-	9,00	7,0	11,50	4231	044091	51,46	044104	56,11
9/16-18	14,288	18	1,411	100	15	-	11,00	9,0	12,90	4232	044092	42,00	044105	56,33
5/8-18	15,875	18	1,411	100	15	-	12,00	9,0	14,50	4233	044093	47,70	044106	51,50

# TARAUDS MACHINE | MASTER TAP G



HSSE  
PM

HL

DIN  
5156

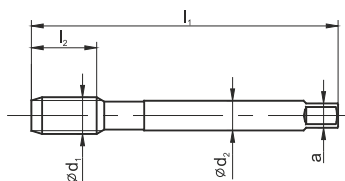

B-HL



< 3 D

C-R45-HL



< 2,5 D



HSSE-PM  
HL  
B / 4-5P  
DROITE

D4-118M01

CODE PRIX PROMO

DIN-371



HSSE-PM  
HL  
C / 2-3P  
HÉLICOÏDALE 45°

D4-528M01

CODE PRIX PROMO

DIN-371

TYPE DE TROU  
QUALITÉ  
REVÊTEMENT  
ENTRÉE  
GOUJURE

G	D1	1"/P	P	L1	L2	L3	D2	a		INDEX	D4-118M01		D4-528M01	
											CODE	PRIX PROMO	CODE	PRIX PROMO
G1/8	9,728	28	0,907	90	10	-	7	5,5	8,80	3123	044107	27,95	044115	30,18
G1/4	13,157	19	1,337	100	14	-	11	9,0	11,80	3127	044108	43,04	044116	49,97
G3/8	16,662	19	1,337	100	15	-	12	9,0	15,25	3129	044109	51,11	044117	54,82
G1/2	20,955	14	1,814	125	17	-	16	12,0	19,00	3131	044110	62,94	044118	67,78
G5/8	22,911	14	1,814	125	20	-	18	14,5	21,00	3133	044111	95,26	044119	102,91
G3/4	26,441	14	1,814	140	20	-	20	16,0	24,50	3135	044112	106,98	044120	115,43
G7/8	30,201	14	1,814	150	22	-	22	18,0	28,25	3137	044113	140,18	044121	151,28
G1	33,249	11	2,309	160	24	-	25	20,0	30,75	3139	044114	192,69	044122	209,03

## TARAUDS MACHINE | VARIANT TIH TICN



TYPE	ÉXÉCUTION	FILETAGE	DIAM	PAS	CODE	€ NET HT
VARIANT 1 TIH	TICN	MJ	4	0,70	043069	70,00
VARIANT 1 TIH	TICN	MJ	5	0,80	043070	77,50
VARIANT 1 TIH	TICN	MJ	6	1,00	043071	79,50
VARIANT 1 TIH	TICN	MJ	8	1,25	073087	94,50
VARIANT 1 TIH	TICN	MJ	10	1,50	073088	112,00
VARIANT 1 TIH	TICN	UNJC	No6	32	073089	57,00
VARIANT 1 TIH	TICN	UNJC	No8	32	073072	57,50
VARIANT 1 TIH	TICN	UNJC	No10	24	073073	62,50
VARIANT 1 TIH	TICN	UNJC	1/4"	20	073074	65,00
VARIANT 1 TIH	TICN	UNJC	5/16"	18	043090	76,50
VARIANT 1 TIH	TICN	UNJC	3/8"	16	043091	90,00
VARIANT 1 TIH	TICN	UNJF	No6	40	043092	60,50
VARIANT 1 TIH	TICN	UNJF	No8	36	043075	61,00
VARIANT 1 TIH	TICN	UNJF	No10	32	043076	66,50
VARIANT 1 TIH	TICN	UNJF	1/4"	28	043077	69,50
VARIANT 1 TIH	TICN	UNJF	5/16"	24	043093	82,00
VARIANT 1 TIH	TICN	UNJF	3/8"	24	043094	96,00

## TARAUDS MACHINE | VARIANT VA HL



TYPE	ÉXÉCUTION	FILETAGE	DIAM	PAS	CODE	€ NET HT
VARIANT 1 VA	HL	M	3	0,50	043035	19,35
VARIANT 1 VA	HL	M	4	0,70	043036	20,11
VARIANT 1 VA	HL	M	5	0,80	043037	21,45
VARIANT 1 VA	HL	M	6	1,00	043038	21,75
VARIANT 1 VA	HL	M	8	1,25	043039	26,85
VARIANT 1 VA	HL	M	10	1,50	043040	30,60
VARIANT 1 VA	HL	M	12	1,75	043041	41,11
VARIANT 1 VA	HL	M	14	2,00	043068	38,70
VARIANT 1 VA	HL	M	16	2,00	043042	54,00
VARIANT 1 VA	HL	M	20	2,50	024649	83,40

# TARAUDS MACHINE | AVANT TIH13 TICN



TYPE	ÉXÉCUTION	FILETAGE	DIAM	PAS	CODE	€ NET HT
AVANT 1 TIH13	TICN	MJ	4	0,70	043095	66,50
AVANT 1 TIH14	TICN	MJ	5	0,80	043078	73,00
AVANT 1 TIH15	TICN	MJ	6	1,00	043079	76,00
AVANT 1 TIH16	TICN	MJ	8	1,25	043080	91,00
AVANT 1 TIH17	TICN	MJ	10	1,50	043096	105,00
AVANT 1 TIH18	TICN	UNJC	No6	32	043097	54,00
AVANT 1 TIH19	TICN	UNJC	No8	32	043098	54,50
AVANT 1 TIH20	TICN	UNJC	No10	24	043081	59,50
AVANT 1 TIH21	TICN	UNJC	1/4"	20	043082	61,00
AVANT 1 TIH22	TICN	UNJC	5/16"	18	043083	73,00
AVANT 1 TIH23	TICN	UNJC	3/8"	16	043099	85,50
AVANT 1 TIH24	TICN	UNJF	No6	40	043100	57,50
AVANT 1 TIH25	TICN	UNJF	No8	36	043101	58,50
AVANT 1 TIH26	TICN	UNJF	No10	32	043084	61,00
AVANT 1 TIH27	TICN	UNJF	1/4"	28	043085	65,50
AVANT 1 TIH28	TICN	UNJF	5/16"	24	043086	77,50
AVANT 1 TIH29	TICN	UNJF	3/8"	24	043102	90,50

# TARAUDS MACHINE | DOMINANT VA45 HL



TYPE	ÉXÉCUTION	FILETAGE	DIAM	PAS	CODE	€ NET HT
DOMINANT 1 VA45	HL	M	3	0,50	043020	22,46
DOMINANT 1 VA45	HL	M	4	0,70	043021	22,46
DOMINANT 1 VA45	HL	M	5	0,80	043022	23,56
DOMINANT 1 VA45	HL	M	6	1,00	043023	24,49
DOMINANT 1 VA45	HL	M	8	1,25	043024	30,42
DOMINANT 1 VA45	HL	M	10	1,50	043025	34,64
DOMINANT 2 VA45	HL	M	12	1,75	043026	46,49
DOMINANT 2 VA45	HL	M	14	2,00	043027	59,90
DOMINANT 2 VA45	HL	M	16	2,00	013788	64,90
DOMINANT 2 VA45	HL	M	20	2,50	043029	95,47

# FRAISES À PLAQUETTES AMOVIBLES | KIT SPINWORX



DR10-025-E12-04

DR10-035-E16-05

DR12-035-E16-05

DR12-052-A22-06

KIT SPINWORX		CODE	PRIX PROMO € NET HT
KIT 1 FR DR10-025-E12-04	+ 50 PL DR10-8B7	087501P	571,00
KIT 1 FR DR10-035-E16-05	+ 50 PL DR10-8B7	087502P	607,00
KIT 1 FR DR10-052-A22-07	+ 50 PL DR10-8B7	087503P	642,00
KIT 1 FR DR12-035-E16-05	+ 50 PL DR12-8B7	087504P	642,00
KIT 1 FR DR12-052-A22-06	+ 50 PL DR12-8B7	087505P	678,00
KIT 1 FR DR12-066-A27-07	+ 50 PL DR12-8B7	087506P	715,00
KIT 1 FR DR10-025-E12-04	+ 50 PL DR10-8E4	087507P	571,00
KIT 1 FR DR10-035-E16-05	+ 50 PL DR10-8E4	087508P	607,00
KIT 1 FR DR10-052-A22-07	+ 50 PL DR10-8E4	087509P	642,00
KIT 1 FR DR12-035-E16-05	+ 50 PL DR12-8E4	087510P	642,00
KIT 1 FR DR12-052-A22-06	+ 50 PL DR12-8E4	087511P	678,00
KIT 1 FR DR12-066-A27-07	+ 50 PL DR12-8E4	087512P	715,00
KIT 1 FR DR10-025-E12-04	+ 50 PL DR10-8F4	087513P	571,00
KIT 1 FR DR10-035-E16-05	+ 50 PL DR10-8F4	087514P	607,00
KIT 1 FR DR10-052-A22-07	+ 50 PL DR10-8F4	087515P	642,00
KIT 1 FR DR12-035-E16-05	+ 50 PL DR12-8F4	087516P	642,00
KIT 1 FR DR12-052-A22-06	+ 50 PL DR12-8F4	087517P	678,00
KIT 1 FR DR12-066-A27-07	+ 50 PL DR12-8F4	087518P	715,00
KIT 1 FR DR10-025-E12-04	+ 50 PL DR10-8C4	087519P	571,00
KIT 1 FR DR10-035-E16-05	+ 50 PL DR10-8C4	087520P	607,00
KIT 1 FR DR10-052-A22-07	+ 50 PL DR10-8C4	087521P	642,00
KIT 1 FR DR12-035-E16-05	+ 50 PL DR12-8C4	087522P	642,00
KIT 1 FR DR12-052-A22-06	+ 50 PL DR12-8C4	087523P	678,00
KIT 1 FR DR12-066-A27-07	+ 50 PL DR12-8C4	087524P	715,00
KIT 1 FR DR10-032-E16-04	+ 50 PL DR10-8B3	087561P	715,00
KIT 1 FR DR10-032-E16-05	+ 50 PL DR10-8B3	087562P	715,00
KIT 1 FR DR10-050-A22-07	+ 50 PL DR10-8B3	087563P	785,00
KIT 1 FR DR12-032-E16-04	+ 50 PL DR12-8B3	087564P	785,00
KIT 1 FR DR12-050-A22-05	+ 50 PL DR12-8B3	087565P	785,00
KIT 1 FR DR12-050-A22-06	+ 50 PL DR12-8B3	087566P	785,00
KIT 1 FR DR12-063-A27-07	+ 50 PL DR12-8B3	087567P	857,00
KIT 1 FR DR12-063-A27-08	+ 50 PL DR12-8B3	087568P	857,00

B3 : INOX | B7 : INOX TITANE | F4 : ACIER P40 | C4 : ACIER DUR P25

## CARACTÉRISTIQUES :

- Utilisation maximale de l'arrête de coupe
- Le temps d'installation réduits puisqu'aucune indexation manuelle des inserts n'est nécessaire
- Le volume copeaux est beaucoup plus élevé (pas d'arrêt machine pour tourner les plaquettes)
- Convient à l'usinage de l'acier, de la fonte, de l'acier inoxydable et des superalliages résistants à la chaleur
- Idéal pour les ébauches, le rainurage, contournage
- Diminution des effort de coupe en raison de la formation de copeaux

| AUTRE COMPOSITION SUR DEMANDE |

# FRAISES À PLAQUETTES AMOVIBLES | KIT FOURWORX



KIT FOURWORX		CODE	PRIX PROMO € NET HT
KIT 1 FR FR05-016-E08-03	+ 100 PL FR05-8242-HF-RP	087525P	857,00
KIT 1 FR FR05-016-E08-03	+ 100 PL FR05-8096-HF-MM	087526P	857,00
KIT 1 FR FR05-020-E10-04	+ 100 PL FR05-8242-HF-RP	087527P	871,00
KIT 1 FR FR05-020-E10-04	+ 100 PL FR05-8096-HF-MM	087528P	871,00
KIT 1 FR FR05-025-E12-05	+ 100 PL FR05-8242-HF-RP	087529P	885,00
KIT 1 FR FR05-025-E12-05	+ 100 PL FR05-8096-HF-MM	087530P	900,00

RP : ACIER | MM : INOX | 8042 : P40 | 8096 : M40

## CARACTÉRISTIQUES :

- Nombre maximal de dents de diamètre minimum
- Des taux d'enlèvement très élevés et des coupes faibles.
- Tous les outils ont un refroidissement intérieur par défaut
- Poche a copeaux 3D pour l'enlèvement optimal des copeaux
- Usinage de presque tous les matériaux
- Idéal pour les pièces fragiles et dans les cavités profondes
- Usinage humide et sec
- Stabilité maximale

# FRAISES À PLAQUETTES AMOVIBLES | KIT QUADWORX



QUADWORX HP



QUADWORX HF

KIT QUADWORX		CODE	PRIX PROMO € NET HT
KIT 1 FR 3Z ø25 248 TAILLE M	+ 100 PL 03 48 842	087549P	715,00
KIT 1 FR 3Z ø25 248 TAILLE M	+ 100 PL 03 48 852	087550P	715,00
KIT 1 FR 3Z ø25 248 TAILLE M	+ 100 PL 03 48 860	087551P	857,00
KIT 1 FR 3Z ø25 248 TAILLE M	+ 100 PL 03 48 896	087552P	785,00
KIT 1 FR 5Z ø35 248 TAILLE M	+ 100 PL 03 48 842	087553P	715,00
KIT 1 FR 5Z ø35 248 TAILLE M	+ 100 PL 03 48 852	087554P	715,00
KIT 1 FR 5Z ø35 248 TAILLE M	+ 100 PL 03 48 860	087555P	857,00
KIT 1 FR 5Z ø35 248 TAILLE M	+ 100 PL 03 48 896	087556P	785,00
KIT 1 FR 5Z ø52 351 TAILLE XL	+ 100 PL 05 51 858 HF	087557P	928,00
KIT 1 FR 5Z ø52 351 TAILLE XL	+ 100 PL 05 51 896 HF	087558P	928,00
KIT 1 FR 5Z ø52 351 TAILLE XL	+ 100 PL 05 51 858 HF	087559P	928,00
KIT 1 FR 5Z ø52 351 TAILLE XL	+ 100 PL 05 51 896 HF	087560P	928,00

842 = P40 | 858 = P25 | 852 = P25 | 860 = K10 | 890 = M40

# FRAISES À PLAQUETTES AMOVIBLES | KIT SLOTWORX



SLOTWORX HF



SLOTWORX HP

KIT SLOTWORX		CODE	PRIX PROMO € NET HT
KIT 1 FR HP 2 10 266 M6	+ 100 PL 02 66 835 R08	087531P	1000,00
KIT 1 FR HP 2 10 266 M6	+ 100 PL 02 66 835 R20	087532P	1000,00
KIT 1 FR HP 2 10 266 M6	+ 100 PL 02 66 890 R20	087533P	1000,00
KIT 1 FR HP 3 12 266 M6	+ 100 PL 02 66 835 R08	087534P	1000,00
KIT 1 FR HP 3 12 266 M6	+ 100 PL 02 66 835 R20	087535P	928,00
KIT 1 FR HP 3 12 266 M6	+ 100 PL 02 66 890 R20	087536P	928,00
KIT 1 FR HP 4 16 266	+ 100 PL 02 66 835 R08	087537P	1000,00
KIT 1 FR HP 4 16 266	+ 100 PL 02 66 835 R20	087538P	1000,00
KIT 1 FR HP 4 16 266	+ 100 PL 02 66 890 R20	087539P	1000,00
KIT 1 FR HF 2 16 267	+ 100 PL 04 67 835 HF	087540P	1000,00
KIT 1 FR HF 2 16 267	+ 100 PL 04 67 848 HF	087541P	857,00
KIT 1 FR HF 2 16 267	+ 100 PL 04 67 862 HF	087542P	857,00
KIT 1 FR HF 3 20 267	+ 100 PL 04 67 835 HF	087543P	1000,00
KIT 1 FR HF 3 20 267	+ 100 PL 04 67 848 HF	087544P	785,00
KIT 1 FR HF 3 20 267	+ 100 PL 04 67 862 HF	087545P	785,00
KIT 1 FR HF 3 25 267	+ 100 PL 04 67 835 HF	087546P	1000,00
KIT 1 FR HF 3 25 267	+ 100 PL 04 67 848 HF	087547P	785,00
KIT 1 FR HF 3 25 267	+ 100 PL 04 67 862 HF	087548P	785,00

835 = HSCO5 | 890 = M40 | 848 = P40 | 862 = K10

## PLAQUETTES | GAMME SBL

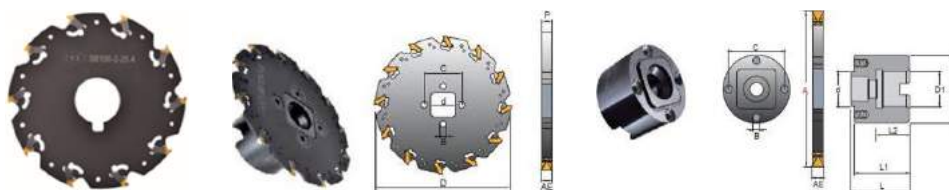

**40/20 PLAQUETTES ACHETÉES = LE CORPS À 2,50 € DU MM\***

\* CLEF ET ENTRETOISE NON INCLUS

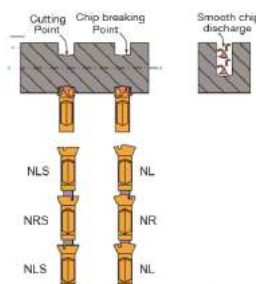
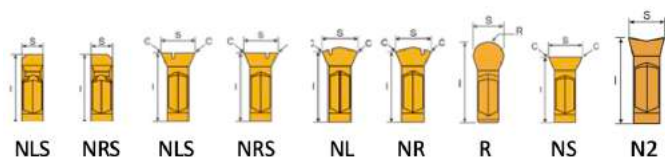

# ALÉSOIRS HSSE | TOLÉRANCE H7 - QUEUE CYLINDRIQUE

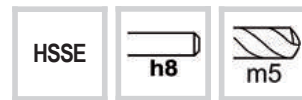

D mm	L mm	L1 mm	L2 mm	D2 mm	Z	CODE	€ NET HT
1,50	40	8	18	2	3	034001	11,15
1,60	43	9	20	2	3	034002	12,48
1,70	43	9	20	2	3	034003	12,48
1,80	46	10	22	2	4	034004	12,48
1,90	46	10	22	2	4	034005	12,48
2,00	49	11	24	2	4	034006	10,80
2,10	49	11	24	2	4	034007	13,12
2,20	53	12	25	3	4	034008	13,12
2,30	53	12	25	3	4	034009	13,12
2,40	57	14	29	3	4	034010	13,12
2,50	57	14	29	3	4	034011	10,80
2,60	57	14	29	3	4	034012	14,00
2,70	61	15	33	3	6	034013	14,00
2,80	61	15	33	3	6	034014	14,00
2,90	61	15	33	3	6	034015	14,00
3,00	61	15	33	3	6	034016	9,88
3,10	65	16	37	4	6	034017	13,12
3,20	65	16	37	4	6	034018	13,12
3,30	65	16	37	4	6	034019	13,12
3,40	70	18	42	4	6	034020	13,12
3,50	70	18	42	4	6	034021	11,55
3,60	70	18	42	4	6	034022	14,78
3,70	70	18	42	4	6	034023	14,78
3,80	75	19	47	4	6	034024	14,78
3,90	75	19	47	4	6	034025	10,52
4,00	75	19	47	4	6	034026	10,80
4,10	75	19	47	4	6	034027	13,80
4,20	75	19	47	4	6	034028	13,80
4,30	80	21	52	5	6	034029	13,80
4,40	80	21	52	5	6	034030	13,80
4,50	80	21	52	5	6	034031	11,55
4,60	80	21	52	5	6	034032	14,78
4,70	80	21	52	5	6	034033	14,78
4,80	86	23	58	5	6	034034	14,78
4,90	86	23	58	5	6	034035	14,78
5,00	86	23	58	5	6	034036	11,15
5,10	86	23	58	5	6	034037	14,78
5,20	86	23	58	5	6	034038	14,78
5,30	86	23	58	5	6	034039	14,78
5,40	93	26	57	6	6	034040	14,78
5,50	93	26	57	6	6	034041	13,80
5,60	93	26	57	6	6	034042	14,78
5,70	93	26	57	6	6	034043	14,78
5,80	93	26	57	6	6	034044	14,78
5,90	93	26	57	6	6	034045	14,78
6,00	93	26	57	6	6	034046	12,00
6,10	101	28	65	6	6	034047	14,78
6,20	101	28	65	6	6	034048	14,78

D mm	L mm	L1 mm	L2 mm	D2 mm	Z	CODE	€ NET HT
6,30	101	28	65	6	6	034049	38,13
6,40	101	28	65	6	6	034050	38,13
6,50	101	28	65	6	6	034051	37,53
6,60	101	28	65	6	6	034052	38,13
6,70	101	28	65	6	6	034053	38,13
6,80	109	31	73	8	6	034054	38,13
6,90	109	31	73	8	6	034055	38,13
7,00	109	31	73	8	6	034056	37,53
7,10	109	31	73	8	6	034057	39,97
7,20	109	31	73	8	6	034058	39,97
7,30	109	31	73	8	6	034059	39,97
7,40	109	31	73	8	6	034060	39,97
7,50	109	31	73	8	6	034061	39,60
7,60	117	33	81	8	6	034062	40,63
7,70	117	33	81	8	6	034063	40,63
7,80	117	33	81	8	6	034064	40,63
7,90	117	33	81	8	6	034065	40,63
8,00	117	33	81	8	6	034066	38,13
8,10	117	33	81	8	6	034067	43,20
8,20	117	33	81	8	6	034068	43,20
8,30	117	33	81	8	6	034069	43,20
8,40	117	33	81	8	6	034070	43,20
8,50	117	33	81	8	6	034071	42,17
8,60	125	36	85	10	6	034072	42,48
8,70	125	36	85	10	6	034073	42,48
8,80	125	36	85	10	6	034074	42,48
8,90	125	36	85	10	6	034075	42,48
9,00	125	36	85	10	6	034076	40,32
9,10	125	36	85	10	6	034077	42,82
9,20	125	36	85	10	6	034078	42,82
9,30	125	36	85	10	6	034079	42,82
9,40	125	36	85	10	6	034080	42,82
9,50	125	36	85	10	6	034081	42,48
9,60	133	38	93	10	6	034082	43,20
9,70	133	38	93	10	6	034083	43,20
9,80	133	38	93	10	6	034084	43,20
9,90	133	38	93	10	6	034085	43,20
10,00	133	38	93	10	6	034086	40,63
11,00	142	41	102	10	6	034087	47,88
12,00	151	44	151	10	6	034088	48,93
13,00	151	44	151	10	6	034089	52,23
14,00	160	47	160	14	8	034090	52,90
15,00	162	50	162	14	8	034091	53,30
16,00	170	52	170	14	8	034092	54,73
17,00	175	54	175	14	8	034093	60,15
18,00	182	56	182	14	8	034094	61,53
19,00	189	58	189	16	8	034095	68,77
20,00	195	60	195	16	8	034096	65,92

# ALÉSOIRS HSSE | TOLÉRANCE H7



D mm	L mm	L1 mm	L2 mm	CM	Z	CODE	€ NET HT
5,00	133	23	67,50	1	6	034120	45,64
6,00	138	26	72,50	1	6	034121	44,04
7,00	150	31	84,50	1	6	034122	54,31
8,00	156	33	90,50	1	6	034123	46,44
9,00	162	36	96,50	1	6	034124	58,15
10,00	168	38	102,50	1	6	034125	39,27
11,00	175	41	109,50	1	6	034126	47,98
12,00	182	44	116,50	1	6	034127	43,25
13,00	182	44	116,50	1	6	034128	47,98
14,00	189	47	123,50	1	8	034129	45,64
15,00	204	50	124,00	2	8	034130	55,89
16,00	210	52	130,00	2	8	034131	55,89
17,00	214	54	134,00	2	8	034132	60,56
18,00	219	56	139,00	2	8	034133	63,71
19,00	223	58	143,00	2	8	034134	70,82
20,00	228	60	148,00	2	8	034135	66,91
21,00	232	62	152,00	2	8	034136	74,76
22,00	237	64	157,00	2	8	034137	74,76
23,00	241	66	161,00	2	8	034138	87,33
24,00	268	68	169,00	3	8	034139	88,05
25,00	268	68	169,00	3	8	034140	92,04
26,00	273	70	174,00	3	8	034141	98,31
27,00	277	71	178,00	3	10	034142	114,84
28,00	277	71	178,00	3	10	034143	107,78
29,00	281	73	182,00	3	10	034144	135,31
30,00	281	73	182,00	3	10	034145	111,69
31,00	285	75	186,00	3	10	034146	162,09
32,00	317	77	193,00	4	10	034147	145,58
33,00	317	77	193,00	4	10	034148	210,87
34,00	321	78	197,00	4	10	034149	165,20

## COFFRET FRAISES À CHANFREINER



**019000**  
99,00€ HT

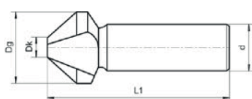

**COFFRET DE FRAISES RÊVÊTUES D6,3 - 10,4 - 16,5 - 20,5 - 25**  
REFERENCE FOURNISSEUR : 14280

- Nano-Tec Revêtement pour une surface extra lisse et empêchant le soudage des matériaux
- Meilleure performance dans presque tous les matériaux
- Jusqu'à 50% d'avance et de force radiale réduite
- Avance travail extrêmement silencieuse
- Fraisage optimal avec une surface exacte, circulaire et sans bavure
- Evacuation optimale des copeaux

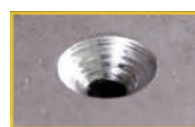

# PORTE-OUTILS | TOURNAGE INTÉRIEUR



## PORTE - OUTILS | CARBURE AVEC ARROSAGE

PORTE-OUTILS INTÉRIEUR	L	ANGLE	P/PL CC	CODE	PRIX TARIF € HT
PO E08K-SCLCR-06	125	95°	0602	090002H	91,00
PO E10M-SCLCR-06	150	95°	0602	090003H	103,00
PO E12Q-SCLCR-06	180	95°	0602	090004H	141,00
PO E16R-SCLCR-09T3	200	95°	09T3	090005H	219,00
PO E25T-SCLCR-12	300	95°	1204	090007H	79,66
PO E08K-SCLCL-06	125	95°	0602	090009H	91,00
PO E10M-SCLCL-06	150	95°	0602	090010H	103,00
PO E12Q-SCLCL-06	180	95°	0602	090011H	141,00
PO E16R-SCLCL-09T3	200	95°	09T3	090012H	219,00
PO E20S-SCLCL-09T3	250	95°	09T3	090013H	358,00
PO E25T-SCLCL-12	300	95°	1204	090014H	560,00

# PLAQUETTES | CCMT - CNMG - APMT - SEKN

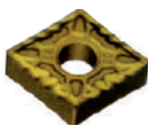

PLAQUETTES	CODE	PRIX TARIF € HT
APKT 1003PDR.I52 T528N	088402	4,50
APKT 1604 PDTR C300	082019P	5,50
APMT 1604 PDR.I52 T528N	088401	4,60
CCGT 060204 AK PC8110	080563	6,80
CCGT 09T304 AK PC8110	080561	8,10
CCMT 060204 HMP PC8110	080472	4,50
CCMT 09T304 HMP PC8110	080492	7,80
CNMG 120404 S 10U	082063	4,20
CNMG 190616 N-MU AC630M	082060	7,50
SEKN 1203 AFTN C300	082905P	4,50

# PINCES CHANGEMENT RAPIDE | TAILLE 42

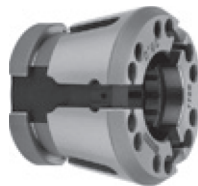
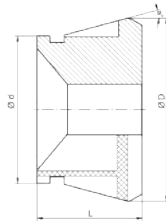

D	PINCES	CODE	PRIX TARIF € HT
4,00	PINCE LISSE GR42	420001	129,00
4,50	PINCE LISSE GR42	420002	129,00
5,00	PINCE LISSE GR42	420003	129,00
5,50	PINCE LISSE GR42	420004	129,00
6,00	PINCE LISSE GR42	420005	129,00
6,50	PINCE LISSE GR42	420006	129,00
7,00	PINCE LISSE GR42	420007	129,00
7,50	PINCE LISSE GR42	420008	129,00
8,00	PINCE LISSE GR42	420009	129,00
8,50	PINCE LISSE GR42	420010	129,00
9,00	PINCE LISSE GR42	420011	129,00
9,50	PINCE LISSE GR42	420012	129,00
10,00	PINCE LISSE GR42	420013	129,00
10,50	PINCE LISSE GR42	420014	129,00
11,00	PINCE LISSE GR42	420015	129,00
11,50	PINCE LISSE GR42	420016	129,00
12,00	PINCE LISSE GR42	420017	129,00
12,50	PINCE LISSE GR42	420018	129,00
13,00	PINCE LISSE GR42	420019	129,00
13,50	PINCE LISSE GR42	420020	129,00
14,00	PINCE LISSE GR42	420021	129,00
14,50	PINCE LISSE GR42	420022	129,00
15,00	PINCE LISSE GR42	420023	129,00
15,50	PINCE LISSE GR42	420024	129,00
16,00	PINCE LISSE GR42	420025	129,00
16,50	PINCE LISSE GR42	420026	129,00
17,00	PINCE LISSE GR42	420027	129,00
17,50	PINCE LISSE GR42	420028	129,00
18,00	PINCE LISSE GR42	420029	129,00
18,50	PINCE LISSE GR42	420030	129,00
19,00	PINCE LISSE GR42	420031	129,00
19,50	PINCE LISSE GR42	420032	129,00
20,00	PINCE LISSE GR42	420033	129,00
20,50	PINCE LISSE GR42	420034	129,00
21,00	PINCE LISSE GR42	420035	129,00
21,50	PINCE LISSE GR42	420036	129,00
22,00	PINCE LISSE GR42	420037	129,00
22,50	PINCE LISSE GR42	420038	129,00
23,00	PINCE LISSE GR42	420039	129,00

D	PINCES	CODE	PRIX TARIF € HT
23,50	PINCE LISSE GR42	420040	129,00
24,00	PINCE LISSE GR42	420041	129,00
24,50	PINCE LISSE GR42	420042	129,00
25,00	PINCE LISSE GR42	420043	129,00
25,50	PINCE LISSE GR42	420044	129,00
26,00	PINCE LISSE GR42	420045	129,00
26,50	PINCE LISSE GR42	420046	129,00
27,00	PINCE LISSE GR42	420047	129,00
27,50	PINCE LISSE GR42	420048	129,00
28,00	PINCE LISSE GR42	420049	129,00
28,50	PINCE LISSE GR42	420050	129,00
29,00	PINCE LISSE GR42	420051	129,00
29,50	PINCE LISSE GR42	420052	129,00
30,00	PINCE LISSE GR42	420053	129,00
30,50	PINCE LISSE GR42	420054	129,00
31,00	PINCE LISSE GR42	420055	129,00
31,50	PINCE LISSE GR42	420056	129,00
32,00	PINCE LISSE GR42	420057	129,00
32,50	PINCE LISSE GR42	420058	129,00
33,00	PINCE LISSE GR42	420059	129,00
33,50	PINCE LISSE GR42	420060	129,00
34,00	PINCE LISSE GR42	420061	129,00
34,50	PINCE LISSE GR42	420062	129,00
35,00	PINCE LISSE GR42	420063	129,00
35,50	PINCE LISSE GR42	420064	129,00
36,00	PINCE LISSE GR42	420065	129,00
36,50	PINCE LISSE GR42	420066	129,00
37,00	PINCE LISSE GR42	420067	129,00
37,50	PINCE LISSE GR42	420068	129,00
38,00	PINCE LISSE GR42	420069	129,00
38,50	PINCE LISSE GR42	420070	129,00
39,00	PINCE LISSE GR42	420071	129,00
39,40	PINCE LISSE GR42	420072	129,00
40,00	PINCE LISSE GR42	420073	129,00
40,50	PINCE LISSE GR42	420074	129,00
41,00	PINCE LISSE GR42	420075	129,00
41,50	PINCE LISSE GR42	420076	129,00
42,00	PINCE LISSE GR42	420077	129,00

D	PINCES	CODE	PRIX TARIF € HT
11,00	PINCE QUADRILLEE GR42	420078	129,00
12,00	PINCE QUADRILLEE GR42	420079	129,00
13,00	PINCE QUADRILLEE GR42	420080	129,00
14,00	PINCE QUADRILLEE GR42	420081	129,00
15,00	PINCE QUADRILLEE GR42	420082	129,00
16,00	PINCE QUADRILLEE GR42	420083	129,00
17,00	PINCE QUADRILLEE GR42	420084	129,00
18,00	PINCE QUADRILLEE GR42	420085	129,00
19,00	PINCE QUADRILLEE GR42	420086	129,00
20,00	PINCE QUADRILLEE GR42	420087	129,00
21,00	PINCE QUADRILLEE GR42	420088	129,00
22,00	PINCE QUADRILLEE GR42	420089	129,00
23,00	PINCE QUADRILLEE GR42	420090	129,00
24,00	PINCE QUADRILLEE GR42	420091	129,00
25,00	PINCE QUADRILLEE GR42	420092	129,00
26,00	PINCE QUADRILLEE GR42	420093	129,00

D	PINCES	CODE	PRIX TARIF € HT
27,00	PINCE QUADRILLEE GR42	420094	129,00
28,00	PINCE QUADRILLEE GR42	420095	129,00
29,00	PINCE QUADRILLEE GR42	420096	129,00
30,00	PINCE QUADRILLEE GR42	420097	129,00
31,00	PINCE QUADRILLEE GR42	420098	129,00
32,00	PINCE QUADRILLEE GR42	420099	129,00
33,00	PINCE QUADRILLEE GR42	420100	129,00
34,00	PINCE QUADRILLEE GR42	420101	129,00
35,00	PINCE QUADRILLEE GR42	420102	129,00
36,00	PINCE QUADRILLEE GR42	420103	129,00
37,00	PINCE QUADRILLEE GR42	420104	129,00
38,00	PINCE QUADRILLEE GR42	420105	129,00
39,00	PINCE QUADRILLEE GR42	420106	129,00
40,00	PINCE QUADRILLEE GR42	420107	129,00
41,00	PINCE QUADRILLEE GR42	420108	129,00
42,00	PINCE QUADRILLEE GR42	420109	129,00

# PINCES CHANGEMENT RAPIDE | TAILLE 65

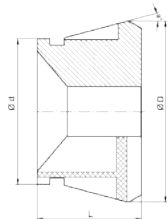

D	PINCES	CODE	PRIX TARIF € HT
6,00	PINCE LISSE GR65	420110	160,00
6,50	PINCE LISSE GR65	420111	160,00
7,00	PINCE LISSE GR65	420112	160,00
7,50	PINCE LISSE GR65	420113	160,00
8,00	PINCE LISSE GR65	420114	160,00
8,50	PINCE LISSE GR65	420115	160,00
9,00	PINCE LISSE GR65	420116	160,00
9,50	PINCE LISSE GR65	420117	160,00
10,00	PINCE LISSE GR65	420118	160,00
10,50	PINCE LISSE GR65	420119	160,00
11,00	PINCE LISSE GR65	420120	160,00
11,50	PINCE LISSE GR65	420121	160,00
12,00	PINCE LISSE GR65	420122	160,00
12,50	PINCE LISSE GR65	420123	160,00
13,00	PINCE LISSE GR65	420124	160,00
13,50	PINCE LISSE GR65	420125	160,00
14,00	PINCE LISSE GR65	420126	160,00
14,50	PINCE LISSE GR65	420127	160,00
15,00	PINCE LISSE GR65	420128	160,00
15,50	PINCE LISSE GR65	420129	160,00
16,00	PINCE LISSE GR65	420130	160,00
16,50	PINCE LISSE GR65	420131	160,00
17,00	PINCE LISSE GR65	420132	160,00
17,50	PINCE LISSE GR65	420133	160,00
18,00	PINCE LISSE GR65	420134	160,00
18,50	PINCE LISSE GR65	420135	160,00
19,00	PINCE LISSE GR65	420136	160,00
19,50	PINCE LISSE GR65	420137	160,00
20,00	PINCE LISSE GR65	420138	160,00
20,50	PINCE LISSE GR65	420139	160,00
21,00	PINCE LISSE GR65	420140	160,00
21,50	PINCE LISSE GR65	420141	160,00
22,00	PINCE LISSE GR65	420142	160,00
22,50	PINCE LISSE GR65	420143	160,00
23,00	PINCE LISSE GR65	420144	160,00
23,50	PINCE LISSE GR65	420145	160,00
24,00	PINCE LISSE GR65	420146	160,00
24,50	PINCE LISSE GR65	420147	160,00
25,00	PINCE LISSE GR65	420148	160,00
25,50	PINCE LISSE GR65	420149	160,00
26,00	PINCE LISSE GR65	420150	160,00
26,50	PINCE LISSE GR65	420151	160,00
27,00	PINCE LISSE GR65	420152	160,00
27,50	PINCE LISSE GR65	420153	160,00
28,00	PINCE LISSE GR65	420154	160,00
28,50	PINCE LISSE GR65	420155	160,00
29,00	PINCE LISSE GR65	420156	160,00
29,50	PINCE LISSE GR65	420157	160,00
30,00	PINCE LISSE GR65	420158	160,00
30,50	PINCE LISSE GR65	420159	160,00
31,00	PINCE LISSE GR65	420160	160,00
31,50	PINCE LISSE GR65	420161	160,00
32,00	PINCE LISSE GR65	420162	160,00
32,50	PINCE LISSE GR65	420163	160,00
33,00	PINCE LISSE GR65	420164	160,00
33,50	PINCE LISSE GR65	420165	160,00
34,00	PINCE LISSE GR65	420166	160,00
34,50	PINCE LISSE GR65	420167	160,00
35,00	PINCE LISSE GR65	420168	160,00
35,50	PINCE LISSE GR65	420169	160,00

D	PINCES	CODE	PRIX TARIF € HT
36,00	PINCE LISSE GR65	420170	160,00
36,50	PINCE LISSE GR65	420171	160,00
37,00	PINCE LISSE GR65	420172	160,00
37,50	PINCE LISSE GR65	420173	160,00
38,00	PINCE LISSE GR65	420174	160,00
38,50	PINCE LISSE GR65	420175	160,00
39,00	PINCE LISSE GR65	420176	160,00
39,50	PINCE LISSE GR65	420177	160,00
40,00	PINCE LISSE GR65	420178	160,00
40,50	PINCE LISSE GR65	420179	160,00
41,00	PINCE LISSE GR65	420180	160,00
41,50	PINCE LISSE GR65	420181	160,00
42,00	PINCE LISSE GR65	420182	160,00
42,50	PINCE LISSE GR65	420183	160,00
43,00	PINCE LISSE GR65	420184	160,00
43,50	PINCE LISSE GR65	420185	160,00
44,00	PINCE LISSE GR65	420186	160,00
44,50	PINCE LISSE GR65	420187	160,00
45,00	PINCE LISSE GR65	420188	160,00
45,50	PINCE LISSE GR65	420189	160,00
46,00	PINCE LISSE GR65	420190	160,00
46,50	PINCE LISSE GR65	420191	160,00
47,00	PINCE LISSE GR65	420192	160,00
47,50	PINCE LISSE GR65	420193	160,00
48,00	PINCE LISSE GR65	420194	160,00
48,50	PINCE LISSE GR65	420195	160,00
49,00	PINCE LISSE GR65	420196	160,00
49,50	PINCE LISSE GR65	420197	160,00
50,00	PINCE LISSE GR65	420198	160,00
50,50	PINCE LISSE GR65	420199	160,00
51,00	PINCE LISSE GR65	420200	160,00
51,50	PINCE LISSE GR65	420201	160,00
52,00	PINCE LISSE GR65	420202	160,00
52,50	PINCE LISSE GR65	420203	160,00
53,00	PINCE LISSE GR65	420204	160,00
53,50	PINCE LISSE GR65	420205	160,00
54,00	PINCE LISSE GR65	420206	160,00
54,50	PINCE LISSE GR65	420207	160,00
55,00	PINCE LISSE GR65	420208	160,00
55,50	PINCE LISSE GR65	420209	160,00
56,00	PINCE LISSE GR65	420210	160,00
56,50	PINCE LISSE GR65	420211	160,00
57,00	PINCE LISSE GR65	420212	160,00
57,50	PINCE LISSE GR65	420213	160,00
58,00	PINCE LISSE GR65	420214	160,00
58,50	PINCE LISSE GR65	420215	160,00
59,00	PINCE LISSE GR65	420216	160,00
59,50	PINCE LISSE GR65	420217	160,00
60,00	PINCE LISSE GR65	420218	160,00
60,50	PINCE LISSE GR65	420219	160,00
61,00	PINCE LISSE GR65	420220	160,00
61,50	PINCE LISSE GR65	420221	160,00
62,00	PINCE LISSE GR65	420222	160,00
62,50	PINCE LISSE GR65	420223	160,00
63,00	PINCE LISSE GR65	420224	160,00
63,50	PINCE LISSE GR65	420225	160,00
64,00	PINCE LISSE GR65	420226	160,00
64,50	PINCE LISSE GR65	420227	160,00
65,00	PINCE LISSE GR65	420228	160,00

# PINCES CHANGEMENT RAPIDE | TAILLE 65

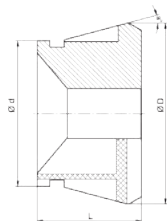

D	PINCES	CODE	PRIX TARIF € HT
11,00	PINCE QUADRILLEE GR65	420229	160,00
12,00	PINCE QUADRILLEE GR65	420230	160,00
13,00	PINCE QUADRILLEE GR65	420231	160,00
14,00	PINCE QUADRILLEE GR65	420232	160,00
15,00	PINCE QUADRILLEE GR65	420233	160,00
16,00	PINCE QUADRILLEE GR65	420234	160,00
17,00	PINCE QUADRILLEE GR65	420235	160,00
18,00	PINCE QUADRILLEE GR65	420236	160,00
19,00	PINCE QUADRILLEE GR65	420237	160,00
20,00	PINCE QUADRILLEE GR65	420238	160,00
21,00	PINCE QUADRILLEE GR65	420239	160,00
22,00	PINCE QUADRILLEE GR65	420240	160,00
23,00	PINCE QUADRILLEE GR65	420241	160,00
24,00	PINCE QUADRILLEE GR65	420242	160,00
25,00	PINCE QUADRILLEE GR65	420243	160,00
26,00	PINCE QUADRILLEE GR65	420244	160,00
27,00	PINCE QUADRILLEE GR65	420245	160,00
28,00	PINCE QUADRILLEE GR65	420246	160,00
29,00	PINCE QUADRILLEE GR65	420247	160,00
30,00	PINCE QUADRILLEE GR65	420248	160,00
31,00	PINCE QUADRILLEE GR65	420249	160,00
32,00	PINCE QUADRILLEE GR65	420250	160,00
33,00	PINCE QUADRILLEE GR65	420251	160,00
34,00	PINCE QUADRILLEE GR65	420252	160,00
35,00	PINCE QUADRILLEE GR65	420253	160,00
36,00	PINCE QUADRILLEE GR65	420254	160,00
37,00	PINCE QUADRILLEE GR65	420255	160,00
38,00	PINCE QUADRILLEE GR65	420256	160,00

D	PINCES	CODE	PRIX TARIF € HT
39,00	PINCE QUADRILLEE GR65	420257	160,00
40,00	PINCE QUADRILLEE GR65	420258	160,00
41,00	PINCE QUADRILLEE GR65	420259	160,00
42,00	PINCE QUADRILLEE GR65	420260	160,00
43,00	PINCE QUADRILLEE GR65	420261	160,00
44,00	PINCE QUADRILLEE GR65	420262	160,00
45,00	PINCE QUADRILLEE GR65	420263	160,00
46,00	PINCE QUADRILLEE GR65	420264	160,00
47,00	PINCE QUADRILLEE GR65	420265	160,00
48,00	PINCE QUADRILLEE GR65	420266	160,00
49,00	PINCE QUADRILLEE GR65	420267	160,00
50,00	PINCE QUADRILLEE GR65	420268	160,00
51,00	PINCE QUADRILLEE GR65	420269	160,00
52,00	PINCE QUADRILLEE GR65	420270	160,00
53,00	PINCE QUADRILLEE GR65	420271	160,00
54,00	PINCE QUADRILLEE GR65	420272	160,00
55,00	PINCE QUADRILLEE GR65	420273	160,00
56,00	PINCE QUADRILLEE GR65	420274	160,00
57,00	PINCE QUADRILLEE GR65	420275	160,00
58,00	PINCE QUADRILLEE GR65	420276	160,00
59,00	PINCE QUADRILLEE GR65	420277	160,00
60,00	PINCE QUADRILLEE GR65	420278	160,00
61,00	PINCE QUADRILLEE GR65	420279	160,00
62,00	PINCE QUADRILLEE GR65	420280	160,00
63,00	PINCE QUADRILLEE GR65	420281	160,00
64,00	PINCE QUADRILLEE GR65	420282	160,00
65,00	PINCE QUADRILLEE GR65	420283	160,00

# MANDRIN DE PERÇAGE



REFERENCE	CAPACITÉ mm	FIXATION K	CODE	PRIX PROMO € HT
SP-13 B-16	1 - 13	B-16	425014B	99,00
SP-16 B-16	3 - 16	B-17	425018B	109,00
SPX-13 B-16	1 - 13	B-18	425033B	117,00
SPX-16 B-16	3 - 16	B-19	425034B	133,00

- **SP** Mandrin de perçage de précision auto-serrant
- **SPX** Mandrin de perçage de précision auto-serrant, avec clef supplémentaire pour machine CNC



REFERENCE	CAPACITÉ mm	CÔNE	PRIX PROMO € HT
NPU-13 ID40	1 - 13	DIN-69871	202,00
NPU-13 BT40	1 - 13	MAS-403 BT	202,00

- **NPU** Mandrin de perçage, monobloc, pour machines conventionnelles et CNC



REFERENCE	CAPACITÉ mm	FIXATION K	CODE	PRIX PROMO € HT
SPS-13 MT-2	1 - 13	CM-2	425240B	130,00
SPS-13 MT-3	1 - 13	CM-3	425241B	136,00
SPS-16 MT-3	3 - 16	CM-3	-	151,00
SPS-13 MT-4	3 - 16	CM-4	425242B	158,00

- **SPS-SOLID** Mandrin de perçage de précision auto-serrant, avec cône morse intégré



REFERENCE	CAPACITÉ mm	CÔNE	PRIX PROMO € HT
HX-13 ID40	1 - 13	DIN-69871	227,00
HX-13 ID40/R	1 - 13	DIN-69871	273,00
HX-13 BT40	1 - 13	MAS-403 BT	227,00

- **HEXA** Mandrin de perçage de précision, monobloc, avec clef six pans



REFERENCE	CAPACITÉ mm	FIXATION K	PRIX PROMO € HT
HB-13 ID40	1 - 13	DIN-69871	187,00
HB-13 BT40	1 - 13	MAS-403 BT	187,00

- **HEXA-BLACK** Mandrin de perçage de précision, monobloc, avec clef six pans



REFERENCE	CAPACITÉ mm	FIXATION K	CODE	PRIX PROMO € HT
CKS-13 B-16	1 - 13	B-16	425003B	62,00
CKS-16 B-16	3 - 16	B-16	425004B	68,00

- **CKS** Mandrin de perçage auto-serrant, pour perceuses portatives et pour machines-outils

# ARBRES ET DOUILLES DE RÉDUCTION



• ES

• CR

REFERENCE	PRIX PROMO € HT
E-16/2	9,00
E-16/3	10,00
CR-3X2	16,00
CR-4X3	22,00

## POINTES TOURNANTES | PETIT DIAMÈTRE



REFERENCE	PRIX PROMO € HT
MODEL RE	
R-300-RE	265,00
R-400-RE	313,00
R-500-RE	446,00

## POINTES TOURNANTES | PRÉCISION



• N

• C

REFERENCE	CÔNE MORSE	CODE	PRIX PROMO € HT
MODEL N			
R-300-N	3	425261B	129,00
R-400-N	4	425262B	164,00
R-500-N	5	425263B	238,00
MODEL C			
R-300-C	3	425280B	146,00
R-400-C	4	425281B	187,00
R-500-C	5	425282B	266,00

# PLAQUETTES BRUT DE FRITTAGE



**6,00**  
€ HT

PROFIL	PAS (en mm)	RÉFÉRENCE	CODE
Profil partiel droit interne	0,50 - 1,50	3 IR CB A60 TiAlN	076950
Profil partiel droit interne	0,50 - 3,00	3 IR CB AG60 TiAlN	076951
Profil partiel droit interne	1,75 - 3,00	3 IR CB G60 TiAlN	076952
Profil complet droit interne	1,00	3 IR CB 1.0 ISO TiAlN	076953
Profil complet droit interne	1,25	3 IR CB 1.25 ISO TiAlN	076954
Profil complet droit interne	1,50	3 IR CB 1.5 ISO TiAlN	076955
Profil complet droit interne	1,75	3 IR CB 1.75 ISO TiAlN	076956
Profil complet droit interne	2,00	3 IR CB 2.0 ISO TiAlN	076957
Profil complet droit interne	2,50	3 IR CB 2.5 ISO TiAlN	076958
Profil complet droit interne	3,00	3 IR CB 3.0 ISO TiAlN	076959
Profil complet droit interne	11 TPI (BSPT)	3 IR CB 11 BSPT TiAlN	076960
Profil partiel droit externe	0,50 - 1,50	3 ER CB A60 TiAlN	076961
Profil partiel droit externe	0,50 - 3,00	3 ER CB AG60 TiAlN	076962
Profil partiel droit externe	1,75 - 3,00	3 ER CB G60 TiAlN	076963
Profil complet droit externe	1,00	3 ER CB 1.0 ISO TiAlN	076964
Profil complet droit externe	1,25	3 ER CB 1.25 ISO TiAlN	076965
Profil complet droit externe	1,50	3 ER CB 1.5 ISO TiAlN	076966
Profil complet droit externe	1,75	3 ER CB 1.75 ISO TiAlN	076967
Profil complet droit externe	2,00	3 ER CB 2.0 ISO TiAlN	076968
Profil complet droit externe	2,50	3 ER CB 2.5 ISO TiAlN	076969
Profil complet droit externe	3,00	3 ER CB 3.0 ISO TiAlN	076970

CONDITIONNEMENT PAR 10

# PLAQUETTES DE FILETAGE

DESIGNATION	Code	DESIGNATION	Code	DESIGNATION	Code	DESIGNATION	Code
16ER 0.50 ISO FC TIALN	076400	16ER 13UN FC TIALN	076086	16IR 1.0 ISO FC TIALN	076418	16IR 18W FC TIALN	076126
16ER 0.70 ISO FC TIALN	076402	16ER 14UN FC TIALN	076087	16IR 1.25 ISO FC TIALN	076419	16IR 19W FC TIALN	076127
16ER 0.75 ISO FC TIALN	076401	16ER 14W FC TIALN	076112	16IR 1.5 ISO FC TIALN	076420	16IR 20UN FC TIALN	076103
16ER 0.80 ISO FC TIALN	076403	16ER 16UN FC TIALN	076088	16IR 1,75 ISO FC TIALN	076430	16IR 20W FC TIALN	076128
16ER 1.00 ISO FC TIALN	076404	16ER 16W FC TIALN	076113	16IR 2.0 ISO FC TIALN	076421	16IR 24UN FC TIALN	076104
16ER 1.25 ISO FC TIALN	076405	16ER 18UN FC TIALN	076089	16IR 2.5 ISO FC TIALN	076422	16IR 24W FC TIALN	076129
16ER 1.50 ISO FC TIALN	076406	16ER 18W FC TIALN	076114	16IR 3.0 ISO FC TIALN	076423	16IR 27UN FC TIALN	076105
16ER 1.75 ISO FC TIALN	076407	16ER 19W FC TIALN	076115	16IR 7W FC TIALN	076119	16IR 28UN FC TIALN	076106
16ER 2.0 ISO FC TIALN	076409	16ER 20UN FC TIALN	076090	16IR 8UN FC TIALN	076094	16IR 28W FC TIALN	076130
16ER 2.5 ISO FC TIALN	076410	16ER 20W FC TIALN	076116	16IR 8W FC TIALN	076120	16IR A55 FC TIALN	076424
16ER 3.0 ISO FC TIALN	076411	16ER 24UN FC TIALN	076091	16IR 9UN FC TIALN	076095	16IR A60 FC TIALN	076425
16ER 7W FC TIALN	076107	16ER 24W FC TIALN	076117	16IR 9W FC TIALN	076121	16IR AG55 FC TIALN	076426
16ER 8UN FC TIALN	076080	16ER 27UN FC TIALN	076092	16IR 10UN FC TIALN	076096	16IR AG60 FC TIALN	076427
16ER 8W FC TIALN	076108	16ER 28UN FC TIALN	076093	16IR 10W FC TIALN	076122	16IR G55 FC TIALN	076428
16ER 9UN FC TIALN	076081	16ER 28W FC TIALN	076118	16IR 11,5UN FC TIALN	076098	16IR G60 FC TIALN	076429
16ER 9W FC TIALN	076109	16ER A55 FC TIALN	076412	16IR 11UN FC TIALN	076097		
16ER 10UN FC TIALN	076082	16ER A60 FC TIALN	076413	16IR 11W FC TIALN	076123		
16ER 11,5 UN FC TIALN	076084	16ER AG55 FC TIALN	076414	16IR 12UN FC TIALN	076099		
16ER 11UN FC TIALN	076083	16ER AG60 FC TIALN	076415	16IR 14UN FFC TIALN	076100		
16ER 11W FC TIALN	076111	16ER G55 FC TIALN	076416	16IR 14W FC TIALN	076124		
16ER 12UN FC TIALN	076085	16ER G60 FC TIALN	076417	16IR 16UN FC TIALN	076101		
				16IR 16W FC TIALN	076125		
				16IR 18UN FC TIALN	076102		

CONDITIONNEMENT PAR 10

**8,50**  
€ HT

# OUTILS CARBURE POUR FLUOPERÇAGE

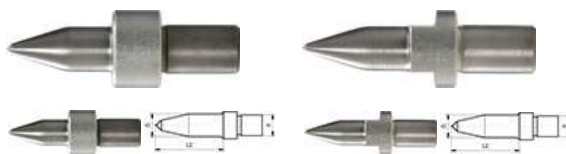

TAILLE	D mm	L2 mm	d mm	MAX EPAISSEUR MAT EN mm	119080		119082	
					SANS TRANCHANT	€ NET HT	AVEC TRANCHANT	€ NET HT
M3	2,70	7,60	6	2,0	019001	62,40	019011	80,40
M4	3,70	10,10	6	2,5	019002	63,60	019012	81,60
M5	4,50	12,00	6	3,0	019003	67,20	019013	105,60
M6	5,40	14,40	8	3,5	019004	74,40	019014	118,80
M8	7,40	18,20	8	4,0	019005	90,00	019015	136,80
M10	9,30	21,70	10	4,5	019006	110,40	019016	156,00
M12	11,00	25,80	12	5,0	019007	121,20	019017	166,80
M14	13,10	31,50	14	5,0	019008	158,40	019018	194,60
M16	14,90	35,70	16	6,0	019009	177,60	019019	219,60
M18	16,80	39,50	18	6,0	019010	222,00	019020	262,80

## 119080 - FORET DE FORAGE EN CARBURE MONOBLOC SANS TRANCHANT

**PROPRIÉTÉS** : Version longue sans arête de coupe | Rectifié polygonale et tige droite pour mandrins à pinces ER.

**UTILISATION** : Pour la production de trous d'écoulement dans des matériaux métalliques à paroi mince sur des perceuses de table et de colonne disponible dans le commerce ainsi que sur des fraiseuses CNC et conventionnelles avec formage de filetage ultérieur.

## 119082 - FORET DE FORAGE EN CARBURE MONOBLOC AVEC TRANCHANT

**PROPRIÉTÉS** : Version longue avec tranchant | Rectifié polygonale et queue droite pour mandrins à pinces ER.

**UTILISATION** : Pour la production de trous d'écoulement dans des matériaux métalliques à paroi mince sur des perceuses de table et de colonne disponible dans le commerce ainsi que sur des fraiseuses CNC et conventionnelles avec formage de filetage ultérieur.

## 119086 - MANDRIN À PINCE AVEC BAGUE DE REFROIDISSEMENT

**PROPRIÉTÉS** : La bague de refroidissement en aluminium réduit l'échauffement du mandrin et de la broche de perçage lors d'une utilisation prolongée

**UTILISATION** : Pour les forets d'écoulement (N° Articles 119080.. et 119082..)



TAILLE D'ENREGISTREMENT	COLLET	PLAGE DE SERRGE EN mm	ANNEAU ø mm	119086	€ NET HT
MK2	ER 32	3-20	85	420555	268,80
MK3	ER 32	3-20	85	420556	315,60



## 119090 - PÂTE À PERCER FLOW HOLE 1KG - CODE 420557 | 57,60€

**UTILISATION** : Pour protéger le foret de trou d'écoulement d'une usure élevée

# FRAISE À CAROTTER | HSS - HSSE-Co5 - HSSE-TIALN



D1 mm	D2 mm	L1 mm	PROFONDEUR DE PERÇAGE en mm	HSS	€ NET HT	HSSE Co 5	€ NET HT	HSSE TiAIN	€ NET HT
12	19	63	30,00	108212	26,50	108212E	34,60	108212F	50,40
13	19	63	30,00	108213	26,85	108213E	34,60	108213F	50,80
14	19	63	30,00	108214	27,20	108214E	34,60	108214F	51,10
15	19	63	30,00	108215	28,30	108215E	34,60	108215F	52,20
16	19	63	30,00	108216	29,30	108216E	35,20	108216F	53,25
17	19	63	30,00	108217	30,45	108217E	36,55	108217F	54,35
18	19	63	30,00	108218	34,25	108218E	41,00	108218F	58,10
19	19	63	30,00	108219	34,90	108219E	41,85	108219F	58,85
20	19	63	30,00	108220	36,35	108220E	43,55	108220F	62,20
21	19	63	30,00	108221	38,90	108221E	46,60	108221F	64,05
22	19	63	30,00	108222	40,60	108222E	48,70	108222F	65,55
23	19	63	30,00	108223	42,00	108223E	50,45	108223F	66,70
24	19	63	30,00	108224	43,60	108224E	52,35	108224F	68,30
25	19	63	30,00	108225	45,10	108225E	54,00	108225F	70,00
26	19	63	30,00	108226	46,30	108226E	55,60	108226F	73,20
27	19	63	30,00	108227	49,95	108227E	59,95	108227F	74,85
28	19	63	30,00	108228	50,00	108228E	60,00	108228F	76,60
29	19	63	30,00	108229	51,85	108229E	62,20	108229F	79,95
30	19	63	30,00	108230	53,15	108230E	63,80	108230F	81,30
31	19	63	30,00	108231	58,00	108231E	69,70	108231F	92,10
32	19	63	30,00	108232	65,30	108232E	78,40	108232F	102,60
33	19	63	30,00	108233	66,15	108233E	79,35	108233F	108,40
34	19	63	30,00	108234	77,10	108234E	92,50	108234F	114,90
35	19	63	30,00	108235	85,00	108235E	101,95	108235F	119,25
36	19	63	30,00	108236	87,10	108236E	104,55	108236F	121,60
37	19	63	30,00	108237	92,10	108237E	110,55	108237F	123,05
38	19	63	30,00	108238	93,45	108238E	112,05	108238F	125,85
39	19	63	30,00	108239	96,95	108239E	116,35	108239F	130,15
40	19	63	30,00	108240	99,30	108240E	119,20	108240F	133,45
41	19	63	30,00	108241	103,35	108241E	124,00	108241F	137,35
42	19	63	30,00	108242	108,95	108242E	130,75	108242F	148,00
43	19	63	30,00	108243	111,35	108243E	133,55	108243F	153,25
44	19	63	30,00	108244	119,20	108244E	143,10	108244F	161,40
45	19	63	30,00	108245	123,10	108245E	147,70	108245F	164,65
46	19	63	30,00	108246	125,60	108246E	150,80	108246F	169,10
47	19	63	30,00	108247	129,85	108247E	155,85	108247F	170,90
48	19	63	30,00	108248	136,00	108248E	163,20	108248F	173,40
49	19	63	30,00	108249	138,05	108249E	165,65	108249F	176,80
50	19	63	30,00	108250	141,50	108250E	169,75	108250F	178,50
51	19	63	30,00	108251	142,35	108251E	173,00	108251F	183,35
55	19	63	30,00	108252	143,25	108252E	176,90	108252F	188,00
52	19	63	30,00	108253	144,25	108253E	181,30	108253F	190,25
54	19	63	30,00	108254	146,70	108254E	185,10	108254F	193,40
55	19	63	30,00	108255	149,70	108255E	189,85	108255F	196,15
56	19	63	30,00	108256	152,95	108256E	191,50	108256F	197,20
57	19	63	30,00	108257	156,10	108257E	196,60	108257F	198,85
58	19	63	30,00	108258	159,50	108258E	199,65	108258F	204,10
59	19	63	30,00	108259	162,90	108259E	199,95	108259F	207,20
60	19	63	30,00	108260	165,90	108260E	204,60	108260F	208,70

| AUTRE PRODUIT AVEC PROFONDEUR DE PERÇAGE EN 55 (mm) SUR DEMANDE |

PRIX PROMOTIONNELS NET HT - OFFRE VALABLE DANS LA LIMITE DES STOCKS DISPONIBLES - VALIDITE 31-12-2020

## TECHMO

30 rue de Montaran  
**45400 FLEURY LES AUBRAIS**  
commercial.techmo@techmo.fr  
☎ 02 38 61 48 10  
☎ 02 38 84 39 63

## TECHMO TOULOUSE

18 chemin de la Violette  
**31240 L'UNION**  
magasin.toulouse@techmo.fr  
☎ 05 61 61 34 35  
☎ 05 61 61 34 44

## TECHMO BORDEAUX

9 rue Laplace  
**33700 MERIGNAC**  
magasin.toulouse@techmo.fr  
☎ 05 61 61 34 35  
☎ 05 61 61 34 44

## SATECH

28 rue Alain Gerbault  
**72100 LE MANS**  
magasin@satech.fr  
☎ 02 43 40 05 05  
☎ 02 43 40 00 99