

OPTI PROD 2022

PRIX PROMOTIONNELS NET HT
OFFRE VALABLE JUSQU'AU 31-12-2022*

SOUS RÉSERVE
DE VARIATIONS
TARIFAIRES

HAUSSE TARIFAIRE DE 5% AU 1^{ER} OCTOBRE 2022



 **TeCHMO**
SaTeCH
GROUPE
Partenaire d'usage

* TECHMO SATECH NE PEUT GARANTIR LES PRIX SUR L'ANNÉE 2022
Nous nous donnons la possibilité de modifier les prix promotionnels en fonction des éventuels changements de prix de nos partenaires.

FRAISES CARBURE | FRAISE À RAINURER

InovaTools
GERMAN TOOLS GROUP

INOX | ACIER



Articles 913.2 ...

D1 H10	L1	L	D2 H6	Z	Articles	Code	Prix promo € net HT
0,5	1	38	3,00	2	913.205.00	366225	8,11
0,6	1	38	3,00	2	913.206.00	366226	8,11
0,7	1	38	3,00	2	913.207.00	366227	8,11
0,8	1	38	3,00	2	913.208.00	366228	8,11
0,9	1	38	3,00	2	913.209.00	366229	8,11
1,0	2	38	3,00	2	913.210.00	366230	7,53
1,1	2	38	3,00	2	913.211.00	366231	7,53
1,2	2	38	3,00	2	913.212.00	366232	7,53
1,4	2	38	3,00	2	913.214.00	366233	7,53
1,5	2	38	3,00	2	913.215.00	366234	7,53
1,6	2	38	3,00	2	913.216.00	366235	6,94
1,7	3	38	3,00	2	913.217.00	366236	6,94
1,8	3	38	3,00	2	913.218.00	366237	6,94
1,9	3	38	3,00	2	913.219.00	366238	6,94
2,0	3	38	3,00	2	913.220.00	366239	6,94
2,5	3	38	3,00	2	913.225.00	366240	6,94
3,0	3	38	3,00	2	913.230.00	366241	6,94

| DANS LA LIMITE DES STOCKS DISPONIBLES |

FRAISES CARBURE | STANDARD - SÉRIE COURTE 2Z

LG

INOX | ACIER

FRAISES CARBURE - SÉRIE COURTE



* JUSQU'À ÉPUISEMENT DES STOCKS

D1	L1	L	D2 H6	Z	Code	Prix promo € net HT
2	6	40	2	2	366200	8,12
2,5	8	40	2,5	2	366201	8,12
3	8	40	3	2	366202	7,84
3,5	8	50	3,5	2	366203	7,84
4	12	40	4	2	366204	7,84
4,5	12	40	4,5	2	366209	7,84
5	14	50	5	2	366205	7,84
5,5	14	50	5,5	2	366211	8,44
6	16	50	6	2	366206	8,44
6,5	16	60	6,5	2	366207	9,44
8	20	60	8	2	366208	9,44
10	22	70	10	2	366210*	15,38
12	22	70	12	2	366212*	19,74
16	25	75	16	2	366216*	32,27
18	26	92	18	2	366218*	42,35
20	32	100	20	2	366220*	56,70

FRAISES CARBURE | STANDARD - SÉRIE COURTE 3Z



INOX | ACIER

FRAISES CARBURE - SÉRIE COURTE



* Jusqu'à épuisement des stocks

D1	L1	L	D2 H6	Z	Code	Prix promo € net HT
2	6	40	2	3	366300	7,84
2,5	10	40	2,5	3	366301	8,99
3	10	40	3	3	366302	7,84
3,5	8	50	3,5	3	366303	8,20
4	12	40	4	3	366304	8,99
4,5	12	40	4,5	3	366307	7,84
5	14	50	5	3	366305	7,84
5,5	14	50	5,5	3	366309	8,44
6	16	50	6	3	366306	8,44
6,5	16	60	6,5	3	366311	9,44
8	20	60	8	3	366308	9,44
10	22	70	10	3	366310	15,41
12	22	70	12	3	366312	22,83
14	25	75	14	3	366314*	24,08
16	25	75	16	3	366316	47,32
18	32	100	18	3	366318*	36,86
20	32	100	20	3	366320	71,34



INOX | ACIER

FRAISES CARBURE - SÉRIE COURTE



D1	L1	L	D2 H6	Z	CYLINDRIQUE		WELDON	
					Code	Prix promo	Code	Prix promo
6	10	57	6	3	366866	10,17	366806	10,17
8	16	63	8	3	366868	14,70	366808	14,70
10	19	72	10	3	366870	19,64	366810	19,64
12	22	83	12	3	366872	28,30	366812	28,30
16	26	92	16	3	366876	47,25	366816	47,25
18	32	104	18	3				
20	32	104	20	3	366880	73,75	366820	73,75

FRAISES CARBURE | STANDARD - SÉRIE NORMALE 4Z



INOX | ACIER

FRAISES CARBURE - SÉRIE NORMALE



D1	L1	L	D2 H6	Z	Code	Prix promo € net HT
2	6	40	2	4	366400	8,13
2,5	10	40	2,5	4	366401	8,13
3	10	40	3	4	366402	8,35
3,5	10	50	3,5	4	366403	9,24
4	11	50	4	4	366404	8,44
4,5	12	40	4,5	4	366407	9,24
5	13	50	5	4	366405	8,44
5,5	14	50	5,5	4	366409	11,70
6	13	57	6	4	366406	12,97
6,5	16	60	6,5	4	366411	15,70
8	19	63	8	4	366408	15,70
10	22	72	10	4	366410	20,70
12	26	83	12	4	366412	30,84
14	32	92	14	4	366414	42,83
16	32	92	16	4	366416	59,03
18	38	100	18	4	366418	86,89
20	38	100	20	4	366420	68,90

FRAISES CARBURE | USINAGE DYNAMIQUE 3Z

InovaTools
GERMAN TOOLS GROUP

ALUMINIUM

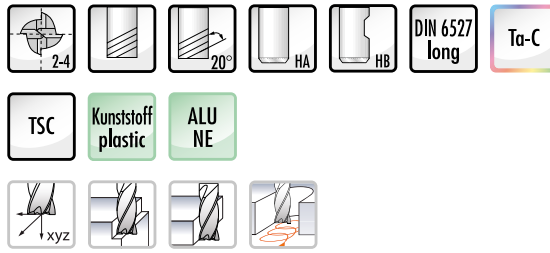
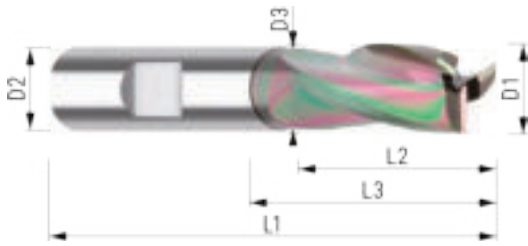

Articles 590 ...

DEUX TAILLES CARBURE MONOBLOC ALUMINIUM

D1	D2 H6	L2	L1	D3	L3	Z	Articles	HA	HB	Code		Prix promo € net HT
										HA	HB	
4,00	4,00	13	54	3,70	16	2	590.04000		363939		42,53
5,00	5,00	15	54	4,70	18	2	590.05000		363940		43,80
6,00	6,00	16	64	5,70	21	2	590.06000	.10	363941	363917	46,65
8,00	8,00	22	70	7,50	27	2	590.08000	.10	363942	363918	61,05
10,00	10,00	25	72	9,50	32	2	590.10000	.10	363943	363919	81,50
12,00	12,00	28	83	11,50	38	3	590.12000	.10	363944	363921	97,87
14,00	14,00	30	83	13,50	42	3	590.14000	.10	363945	363936	128,23
16,00	16,00	36	92	15,50	44	3	590.16000	.10	363946	363922	162,29
18,00	18,00	36	92	17,50	50	3	590.18000	.10	363947	363937	192,55
20,00	20,00	41	104	19,50	54	4	590.20000	.10	363948	363920	249,48
25,00	25,00	43	110	24,50	63	4	590.25000	.10	363949	363938	344,06

FRAISES CARBURE | FRAISE D'ÉBAUCHE 3Z

InovaTools
GERMAN TOOLS GROUP

ALUMINIUM

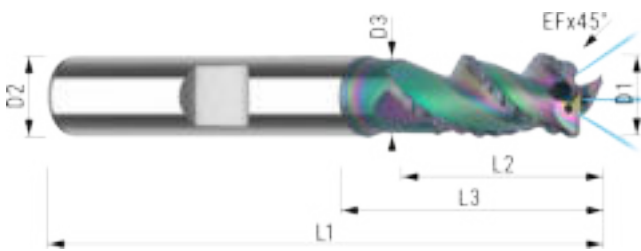

Articles 251 ...

FRAISE D'ÉBAUCHE CARBURE MONOBLOC AVEC TROUS D'HUILE PRIMUS

D1	D2 H6	L2	L1	D3	L3	ER	Z	Articles	Code	Prix promo € net HT
6,00	6,00	14	57	5,70	20	0,20	3	251.060.00	3630020	72,01
8,00	8,00	21	63	7,40	26	0,25	3	251.080.00	3630021	83,23
10,00	10,00	23	72	9,50	31	0,30	3	251.100.00	3630022	101,75
12,00	12,00	27	83	11,00	37	0,35	2	251.120.00	3630023	125,03
16,00	16,00	36	92	15,00	43	0,40	3	251.160.00	3630024	171,59
20,00	20,00	41	104	19,00	52	0,40	3	251.200.00	3630025	241,38

FRAISES CARBURE | FRAISE D'ÉBAUCHE 3Z

InovaTools
GERMAN TOOLS GROUP

ALUMINIUM

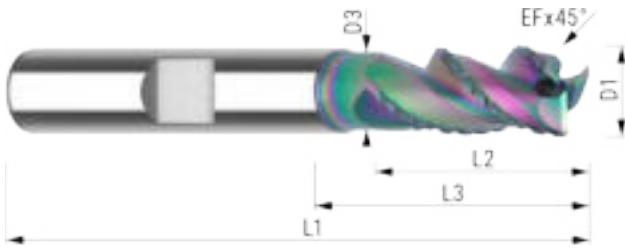

Articles 2.413

FRAISE D'ÉBAUCHE CARBURE MONOBLOC PRIMUS

D1	D2 H6	L2	L1	D3	L3	EF	Z	Articles	Code	Prix promo € net HT
6,00	6,00	14	57	5,90	20	0,20	3	2413.060.00	3630073	56,28
8,00	8,00	21	63	7,80	26	0,25	3	2413.080.00	3630074	65,05
10,00	10,00	23	72	8,00	31	0,30	3	2413.100.00	3630075	79,54
12,00	12,00	27	83	11,70	37	0,35	3	2413.120.00	3630076	97,74
16,00	16,00	36	92	15,70	43	0,40	3	2413.160.00	3630077	134,13
20,00	20,00	41	104	19,50	52	0,40	3	2413.200.00	3630078	188,65

FRAISES CARBURE | FRAISE TORIQUE ALUMINIUM 2Z

InovaTools
GERMAN TOOLS GROUP

ALUMINIUM

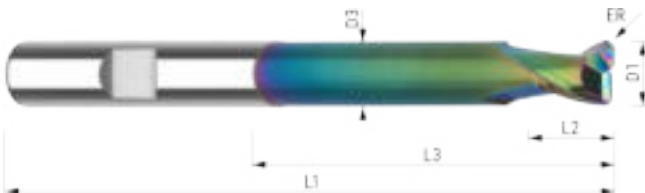

Articles 2.408

FRAISE TORIQUES CARBURE MONOBLOC AVEC RAYON

D1	D2 H6	L2	L1	D3	L3	ER	Z	Articles	Code	Prix promo € net HT
3,00	6,00	4	75	2,90	32	0,30	2	2408.030.00	3630026	46,07
4,00	6,00	5	75	3,90	36	0,30	2	2408.040.00	3630027	51,03
5,00	6,00	6	75	4,90	40	0,30	2	2408.050.00	3630028	56,32
6,00	6,00	7	80	5,80	44	0,30	2	2408.060.00	3630029	60,77
6,00	6,00	7	80	5,80	44	1,00	2	2408.061.00	3630030	60,77
6,00	6,00	7	80	5,80	44	2,00	2	2408.062.00	3630031	60,77
8,00	8,00	9	100	7,80	54	0,30	2	2408.080.00	3630032	85,17
8,00	8,00	9	100	7,80	54	1,00	2	2408.081.00	3630033	85,17
8,00	8,00	9	100	7,80	54	2,00	2	2408.082.00	3630034	85,17
10,00	10,00	11	100	9,70	60	0,30	2	2408.100.00	3630035	114,78
10,00	10,00	11	100	9,70	60	1,50	2	2408.101.00	3630036	114,78
10,00	10,00	11	100	9,70	60	3,00	2	2408.102.00	3630037	114,78
12,00	12,00	13	120	11,70	75	1,50	2	2408.120.00	3630038	153,16
12,00	12,00	13	120	11,70	75	4,00	2	2408.121.00	3630039	153,16
16,00	16,00	17	150	15,70	92	2,00	2	2408.160.00	3630040	258,55
16,00	16,00	17	150	15,70	92	5,00	2	2408.161.00	3630041	258,55

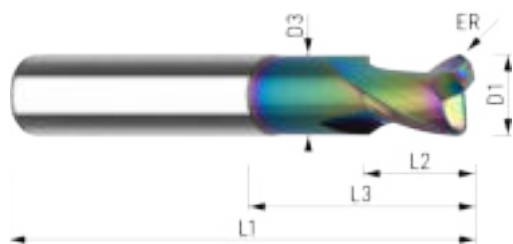

Articles 2.409

DEUX TAILLES CARBURE MONOBLOC AVEC RAYON

D1	D2 H6	L2	L1	D3	L3	ER	Z	Articles	Code	Prix promo € net HT
3,00	6,00	4	50	2,90	14	0,30	2	2409.030.00	3630042	34,73
4,00	6,00	5	50	3,90	16	0,30	2	2409.040.00	3630043	39,85
5,00	6,00	6	54	4,90	18	0,30	2	2409.050.00	3630044	43,02
6,00	6,00	7	57	5,80	21	0,30	2	2409.060.00	3630045	47,61
6,00	6,00	7	57	5,80	21	1,00	2	2409.061.00	3630046	47,61
6,00	6,00	7	57	5,80	21	2,00	2	2409.062.00	3630047	47,61
8,00	8,00	9	63	7,80	27	0,30	2	2409.080.00	3630048	63,81
8,00	8,00	9	63	7,80	27	1,00	2	2409.081.00	3630049	63,81
8,00	8,00	9	63	7,80	27	2,00	2	2409.082.00	3630050	63,81
10,00	10,00	11	72	9,70	32	0,30	2	2409.100.00	3630051	84,48
10,00	10,00	11	72	9,70	32	1,50	2	2409.101.00	3630052	84,48
10,00	10,00	11	72	9,70	32	3,00	2	2409.102.00	3630053	84,48
12,00	12,00	13	83	11,70	38	1,50	2	2409.120.00	3630054	113,49
12,00	12,00	13	83	11,70	38	4,00	2	2409.121.00	3630055	113,49
16,00	16,00	17	92	15,70	44	2,00	2	2409.160.00	3630056	185,14
16,00	16,00	17	92	15,70	44	5,00	2	2409.161.00	3630057	185,14

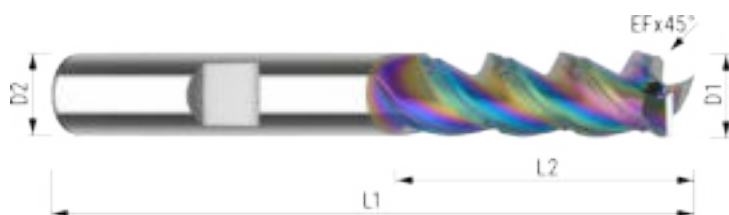

Articles 2.414

USINAGE DYNAMIQUE

D1	D2 H6	L2	L1	EF	Z	Articles	Code	Prix promo € net HT
6,00	6,00	21	62	0,20	3	2414.060.00	3630079	55,80
8,00	8,00	28	68	0,20	3	2414.080.00	3630080	60,77
10,00	10,00	35	80	0,20	3	2414.100.00	3630081	80,89
12,00	12,00	42	93	0,20	3	2414.120.00	3630082	121,15
16,00	16,00	56	108	0,20	3	2414.160.00	3630083	172,35
20,00	20,00	70	126	0,20	3	2414.200.00	3630084	243,16

FRAISES CARBURE | FRAISE TORIQUE ALUMINIUM 3Z

InovaTools
GERMAN TOOLS GROUP

ALUMINIUM

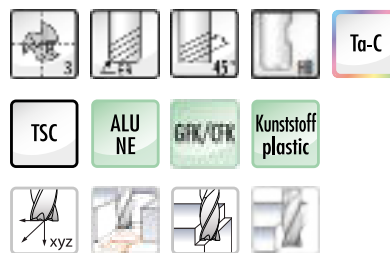
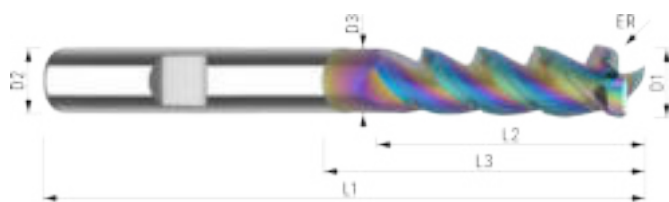

Articles 2.410

FRAISE CARBURE MONOBLOC AVEC RAYON

D1	D2 H6	L2	L1	D3	L3	ER	Z	Articles	Code	Prix promo € net HT
6,00	6,00	25	71	5,80	31	0,50	3	2410.060.00	3630058	46,41
6,00	6,00	25	71	5,80	31	1,00	3	2410.061.00	3630059	46,41
8,00	8,00	33	80	7,80	41	0,50	3	2410.080.00	3630060	55,12
8,00	8,00	33	80	7,80	41	1,00	3	2410.081.00	3630061	55,12
8,00	8,00	33	80	7,90	41	2,00	3	2410.082.00	3630062	55,12
10,00	10,00	41	95	9,70	51	0,50	3	2410.100.00	3630063	82,09
10,00	10,00	41	95	9,70	51	1,00	3	2410.101.00	3630064	82,09
10,00	10,00	41	95	9,70	51	2,00	3	2410.102.00	3630065	82,09
12,00	12,00	49	109	11,70	61	0,50	3	2410.120.00	3630066	111,78
12,00	12,00	49	109	11,70	61	1,00	3	2410.121.00	3630067	111,78
12,00	12,00	49	109	11,70	61	2,00	3	2410.122.00	3630068	111,78
16,00	16,00	65	132	15,80	81	2,00	3	2410.160.00	3630069	206,49
16,00	16,00	65	132	15,70	81	3,00	3	2410.161.00	3630070	206,49
20,00	20,00	82	154	19,50	101	2,00	3	2410.200.00	3630071	301,19
20,00	20,00	82	154	19,50	101	3,00	3	2410.201.00	3630072	301,19

FRAISES CARBURE | FRAISE ALUMINIUM 3Z

InovaTools
GERMAN TOOLS GROUP

ALUMINIUM

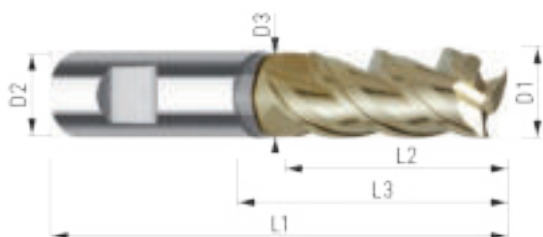

Articles 945 ...

D1	D2	L2	L1	D3	L3	Z	Articles	Code	Prix promo € net HT
3,00	6,00	12	38			3	945.030.19	366982	18,51
4,00	6,00	12	54	3,80	18	3	945.040.19	366983	18,51
5,00	6,00	15	54	4,80	18	3	945.050.19	366984	18,51
6,00	6,00	16	57	5,80	21	3	945.060.19	366985	20,14
8,00	8,00	22	63	7,80	28	3	945.080.19	366986	29,90
10,00	10,00	25	72	9,70	33	3	945.100.19	366987	39,35
12,00	12,00	28	83	11,70	39	3	945.120.19	366988	52,93
16,00	16,00	35	93	15,70	45	3	945.160.19	366989	80,17
20,00	20,00	40	104	19,70	54	3	945.200.19	366990	125,38
25,00	25,00	40	121	23,00	65	3	945.250.19	366991	205,52

FRAISES CARBURE | FRAISE ALUMINIUM 3Z

InovaTools
GERMAN TOOLS GROUP

ALUMINIUM

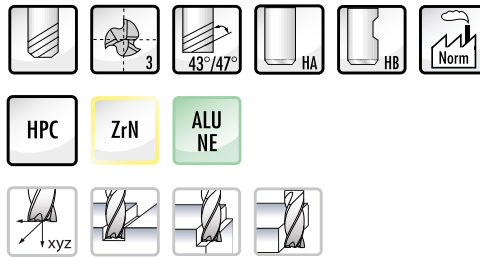
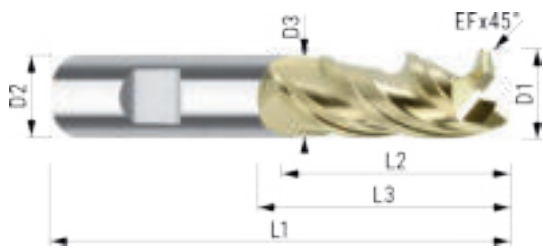

Articles 244 ...

D1	D2	L2	L1	D3	L3	EF	Z	Articles	HA	HB	Code		Prix promo € net HT
											HA	HB	
3,00	6,00	8	57	2,80	12	0,10	3	244.03000	.10	363810		31,50
4,00	6,00	11	57	3,80	18	0,10	3	244.04000	.10	363811		31,50
5,00	6,00	13	57	4,80	18	0,10	3	244.05000	.10	363812		31,50
6,00	6,00	13	57	0,80	18	0,20	3	244.06000	.10	363813		33,13
6,00	6,00	13	80	5,80	42	0,20	3	244.06100	.10	363814		44,43
8,00	8,00	21	63	7,80	25	0,20	3	244.08000	.10	363815		37,98
8,00	8,00	21	100	7,80	62	0,20	3	244.08100	.10	363816		58,98
10,00	10,00	22	72	9,70	30	0,20	3	244.10000	.10	363817		64,64
10,00	10,00	22	100	9,70	58	0,20	3	244.10100	.10	363818		84,83
12,00	12,00	26	83	11,70	36	0,20	3	244.12000	.10	363819		87,25
12,00	12,00	26	120	11,70	73	0,20	3	244.12100	.10	363820		121,19
16,00	16,00	36	92	15,70	42	0,20	3	244.16000	.10		363821	160,78
16,00	16,00	36	150	15,70	100	0,20	3	244.16100	.10		363822	257,73
18,00	18,00	36	92	17,60	15	0,20	3	244.18000	.10		363823	177,75
18,00	18,00	36	150	17,60	100	0,20	3	244.18100	.10		363824	273,89
20,00	20,00	41	104	19,50	52	0,20	3	244.20000	.10		363825	230,26
20,00	20,00	41	150	19,50	98	0,20	3	244.20100	.10		363826	330,44
25,00	25,00	50	121	24,50	65	3,00	3	244.25000	.10		363827	351,45

TiP ALUMINIUM

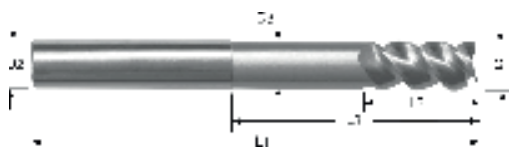

FRAISES CARBURE AL3SL - SÉRIE LONGUE

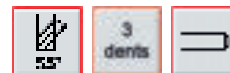

D1 H10	D2 H6	D3	L2	L1	L3	Z	Code	Prix promo € net HT
10	10	9,70	20	110	50	3	368720	61,57
12	12	11,70	24	110	50	3	368721	80,45
12	12	11,70	24	110	60	3	368722	83,37
16	16	15,60	32	125	60	3	368723	128,29
16	16	15,60	32	125	70	3	368724	131,23
20	20	19,60	38	125	60	3	368725	182,21
20	20	19,60	38	125	70	3	368726	184,19

FRAISES CARBURE | FRAISE TORIQUE ALUMINIUM 3Z

TiP ALUMINIUM



FRAISES CARBURE AL3SL+R TORIQUE - SÉRIE NORMALE



D1 H10	D2 H6	D3	L2	L1	L3	R	Z	Code	Prix promo € net HT
10	10	9,70	20	110	50	1,5	3	368732	63,76
12	12	11,70	21	110	50	1,5	3	368733	82,36
12	12	11,70	21	110	60	1,5	3	368734	86,27
16	16	15,60	32	125	60	2,5	3	368735	135,88
16	16	15,60	32	125	70	2,5	3	368736	139,03
16	16	15,60	32	125	60	4,0	3	368737	140,26
16	16	15,60	32	125	70	4,0	3	368738	144,08
20	20	19,6	38	125	60	2,5	3	368739	182,87
20	20	19,60	38	125	70	2,5	3	368740	186,08
20	20	19,60	38	125	60	4,0	3	368741	188,05
20	20	19,60	38	125	70	4,0	3	368742	191,36

FRAISES CARBURE | FRAISES À FILETER - PAS MÉTRIQUE

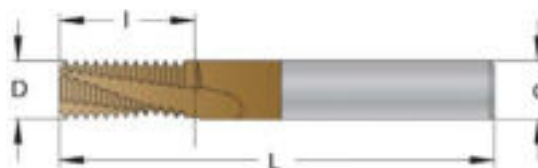

PAS mm	M GROS	d	D	l	L	Z	Code	Prix promo € net HT	PAS mm	M GROS	d	D	l	L	Z	Code	Prix promo € net HT
0,40	M2 (1,5xD)	4	1,50	3,40	50	3	093070	100,57	1,00	M6 (2,5xD)	6	4,50	16,50	63	3	093104	141,36
0,40	M2 (2xD)	4	1,50	4,60	50	3	093071	110,64	1,00	M6 (3xD)	6	4,50	19,50	63	3	093105	155,53
0,45	M2,2 (1,5xD)	4	1,60	3,82	50	3	093072	100,56	1,25	M8 (1,5xD)	6	6,00	14,37	63	3	093109	116,87
0,45	M2,2 (2xD)	4	1,60	5,17	50	3	093073	110,64	1,25	M8 (2xD)	6	6,00	18,12	63	3	093110	128,60
0,45	M2,5 (1,5xD)	4	1,90	4,27	50	3	093074	100,56	1,25	M8 (2,5xD)	6	6,00	21,87	63	3	093111	141,36
0,45	M2,5 (2xD)	4	1,90	5,62	50	3	093075	110,64	1,25	M8 (3xD)	6	6,00	25,62	76	3	093112	155,53
0,50	M3 (1,5xD)	4	2,30	5,25	50	3	093076	100,56	1,50	M10 (1,5xD)	8	7,50	17,25	63	3	093113	147,89
0,50	M3 (2xD)	4	2,30	6,75	50	3	093077	110,64	1,50	M10 (2xD)	8	7,50	21,75	76	3	093114	162,70
0,50	M3 (2,5xD)	4	2,30	8,25	50	3	093078	121,67	1,50	M10 (2,5xD)	8	7,50	27,75	76	3	093115	178,76
0,50	M3 (1,5xD)	6	2,30	5,25	63	3	093079	116,87	1,50	M10 (3xD)	8	7,50	32,25	76	3	093116	196,80
0,50	M3 (2xD)	6	2,30	6,75	63	3	093080	128,60	1,75	M12 (1,5xD)	8	8,00	20,12	76	3	093120	147,89
0,50	M3 (2,5xD)	6	2,30	8,25	63	3	093081	141,36	1,75	M12 (2xD)	8	8,00	27,12	76	3	093121	162,70
0,60	M3,5 (1,5xD)	4	2,60	6,30	50	3	093084	100,56	1,75	M12 (1,5xD)	10	9,00	20,12	76	3	093122	188,13
0,60	M3,5 (2xD)	4	2,60	8,10	50	3	093085	110,64	1,75	M12 (2xD)	10	9,00	27,12	76	3	093123	206,88
0,70	M4 (1,5xD)	4	3,00	7,35	50	3	093086	100,56	1,75	M12 (2,5xD)	10	9,00	32,37	100	3	093124	227,43
0,70	M4 (2xD)	4	3,00	8,75	50	3	093087	110,64	1,75	M12 (3xD)	10	9,00	37,62	100	3	093125	250,27
0,70	M4 (2,5xD)	4	3,00	10,85	50	3	093088	121,67	2,00	M14 (1,5xD)	10	10,00	23,00	76	3	093126	188,13
0,70	M4 (1,5xD)	6	3,00	7,35	63	3	093089	116,87	2,00	M14 (2xD)	10	10,00	31,00	100	3	093127	206,88
0,70	M4 (2xD)	6	3,00	8,75	63	3	093090	128,60	2,00	M14 (2,5xD)	10	10,00	37,00	100	3	093128	227,43
0,70	M4 (2,5xD)	6	3,00	10,85	63	3	093091	141,36	2,00	M16 (1,5xD)	12	12,00	27,00	83	4	093129	220,82
0,75	M4,5 (1,5xD)	4	3,40	7,87	50	3	093092	100,56	2,00	M16 (2xD)	12	12,00	35,00	100	4	093130	243,02
0,75	M4,5 (2xD)	4	3,40	10,12	50	3	093093	110,64	2,00	M16 (2,5xD)	12	12,00	43,00	100	4	093131	267,12
0,80	M5 (1,5xD)	4	3,80	8,40	50	3	093096	100,56	2,00	M16 (3xD)	12	12,00	51,00	100	3	093132	293,97
0,80	M5 (2xD)	4	3,80	10,80	50	3	093097	110,64	2,50	M18 (1,5xD)	12	12,00	31,25	100	3	093136	243,02
0,80	M5 (2,5xD)	4	3,80	13,20	50	3	093098	121,67	2,50	M18 (2xD)	12	12,00	38,75	100	3	093137	267,12
0,80	M5 (1,5xD)	6	3,80	8,40	63	3	093099	116,87	2,50	M18 (2,5xD)	12	12,00	48,75	100	3	093138	293,97
0,80	M5 (2xD)	6	3,80	10,80	63	3	093100	128,60	2,50	M18 (1,5xD)	14	14,00	33,75	89	4	093139	274,52
0,80	M5 (2,5xD)	6	3,80	13,20	63	3	093101	141,36	2,50	M20 (2xD)	14	14,00	43,75	100	4	093140	301,85
1,00	M6 (1,5xD)	6	4,50	10,50	63	3	093102	116,87	2,50	M20 (2,5xD)	16	15,00	53,75	120	4	093141	384,30
1,00	M6 (2xD)	6	4,50	13,50	63	3	093103	128,60	2,50	M20 (3xD)	16	15,00	63,75	120	3	093142	349,34

FRAISES CARBURE | FRAISES À FILETER

INCONEL | TITANE | INOX | ACIER | ALUMINIUM

UNE DENT



M	M FIN	UNC UNF	d	D	Z	I	L	Code	Prix promo € net HT
M2	0,35 - 0,40	N°2 (2,0xD)	4	1,50	4	4,4	50	093161	64,58
M2	0,35 - 0,40	N°2 (3,0xD)	4	1,50	4	6,4	50	093162	71,03
M2,2	0,45	N°2 (2,0xD)	4	1,65	4	5	50	093163	64,58
M2,2	0,45	N°2 (3,0xD)	4	1,65	4	7,1	50	093164	71,03
M2,5	0,45 - 0,50	N°3 (2,0xD)	4	1,90	4	5,5	50	093165	64,58
M2,5	0,45 - 0,50	N°3 (3,0xD)	4	1,90	4	8	50	093166	71,03
		N°4 (2,0xD)	4	2,10	4	6,4	50	093167	64,58
		N°4 (3,0xD)	4	2,10	4	9,2	50	093168	71,03
M3	0,50 - 0,60	N°5 (2,0xD)	4	2,30	4	6,5	50	093169	64,58
M3	0,50 - 0,60	N°5 (3,0xD)	4	2,30	4	9,5	50	093170	71,03
M3,5	0,50 - 0,75	N°6 (2,0xD)	4	2,60	4	7,6	50	093171	71,03
M3,5	0,50 - 0,75	N°6 (3,0xD)	4	2,60	4	11,1	50	093172	64,58
M4	0,70 - 0,75	N°8 (2,0xD)	4	3,00	4	9	50	093173	64,58
M4	0,70 - 0,75	N°8 (3,0xD)	4	3,00	4	13	50	093174	71,03
M4,5	0,75 - 1,00	N°10 (2,0xD)	4	3,60	4	10	50	093175	64,58
M4,5	0,75 - 1,00	N°10 (3,0xD)	4	3,60	4	14,3	50	093176	71,03
M5	0,75 - 1,00	N°12 (2,0xD)	4	4,00	4	11	50	093177	64,58
M5	0,75 - 1,00	N°12 (3,0xD)	4	4,00	4	16	50	093178	71,03

INCONEL | TITANE | INOX | ACIER | ALUMINIUM

DEUX DENTS



M GROS		d	D	Z	I	L	Code	Prix promo € net HT
M2	x 0,40 (2,0xD)	4	1,50	4	4,40	50	093143	77,49
M2	x 0,40 (3,0xD)	4	1,50	4	6,40	50	093144	85,21
M2,2	x 0,45 (2,0xD)	4	1,65	4	5,00	50	093145	77,49
M2,2	x 0,45 (3,0xD)	4	1,65	4	7,10	50	093146	85,21
M2,5	x 0,45 (2,0xD)	4	1,90	4	5,50	50	093147	77,49
M2,5	x 0,45 (3,0xD)	4	1,90	4	8,00	50	093148	85,21
M3	x 0,50 (2,0xD)	4	2,30	5	6,50	50	093149	77,49
M3	x 0,50 (3,0xD)	4	2,30	5	9,50	50	093150	85,21
M3,5	x 0,60 (2,0xD)	4	2,60	5	7,60	50	093151	77,49
M3,5	x 0,60 (3,0xD)	4	2,60	5	11,10	50	093152	85,21
M4	x 0,70 (2,0xD)	4	3,00	5	9,00	50	093153	77,49
M4	x 0,70 (3,0xD)	4	3,00	5	13,00	50	093154	85,21
M5	x 0,80 (2,0xD)	4	3,40	5	10,00	50	093155	77,49
M5	x 0,80 (3,0xD)	4	3,40	5	14,30	50	093156	85,21
M6	x 1,00 (2,0xD)	4	3,80	5	11,00	50	093157	90,02
M6	x 1,00 (3,0xD)	4	3,80	5	16,00	50	093158	99,00
M8	x 1,25 (2,0xD)	4	4,50	5	13,00	63	093159	90,02
M8	x 1,25 (3,0xD)	4	4,50	5	19,00	76	093160	99,00

FRAISES HSS | FRAISE FINITION ACIER FRITTÉ WX6 - 505



TITANE | INOX | ACIER



FRAISES DEUX TAILLES FINITION
SÉRIE MOYENNE

- NORME USINE
- COUPE AU CENTRE
- HÉLICE 40°



D Js14	Lt	LT	d h8	Z	Code	Prix promo € net HT
3	8	52	6	4	015597	11,22
4	11	55	6	4	015598	11,22
5	13	57	6	4	015599	13,93
6	16	60	6	4	015600	13,93
7	22	72	10	4	015601	21,31
8	25	75	10	4	015602	21,31
9	25	75	10	4	015603	21,31
10	28	78	10	4	015604	21,31
11	28	85	12	4	015605	27,86
12	32	89	12	4	015606	27,86
13	32	89	12	4	015607	32,78
14	32	92	16	4	015617	36,08
15	36	96	16	4	015618	36,08
16	36	96	16	4	015608	36,08
17	40	100	16	4	015609	38,48
18	40	100	16	4	015610	41,00
19	45	105	16	4	015611	46,75
20	45	111	20	4	015612	49,08
22	46	111	20	5	015613	71,44
25	50	126	25	5	015614	72,16
30	63	139	25	6	015615	93,86
32	63	143	32	6	015616	104,16

FRAISES HSS | FRAISE D'ÉBAUCHE ACIER FRITTÉ WX6 - 630C



TITANE | INOX | ACIER



FRAISES RAVAGEUSES DEUX TAILLES
SÉRIE MOYENNE

- NORME USINE
- COUPE AU CENTRE
- HÉLICE 30°



D Js14	Lt	LT	d h6	Z	Code	Prix promo € net HT
6	13	57	6	3	015530	23,76
8	19	69	10	3	015532	32,78
10	22	72	10	3	015534	32,78
12	26	83	12	3	015536	36,08
14	26	83	12	4	015538	38,84
16	32	92	16	4	015540	40,81
18	32	92	16	4	015541	53,80
20	38	104	20	4	015543	54,95
25	45	121	25	4	015544	97,26

FRAISES HSS | FRAISE D'ÉBAUCHE ACIER FRITTÉ WX6 - 635C



TITANE | INOX | ACIER



FRAISES RAVAGEUSES DEUX TAILLES
SÉRIE MOYENNE

- NORME USINE
- COUPE AU CENTRE
- HÉLICE 30°



D Js14	Lt	LT	d h6	Z	Code	Prix promo € net HT
6	16	60	6	3	015690	23,76
7	22	72	10	3	015691	32,78
8	25	75	10	3	015692	32,78
9	25	75	10	4	015693	32,78
10	28	78	10	4	015694	32,78
11	28	85	12	4	015695	36,08
12	32	89	12	4	015696	36,08
13	32	89	12	4	015697	40,18
14	32	92	16	4	015698	45,91
15	36	96	16	4	015699	45,91
16	36	96	16	4	015700	48,21
17	40	100	16	4	015701	53,39
18	40	100	16	4	015702	53,39
19	45	105	16	4	015703	57,69
20	45	111	20	4	015704	57,69
22	45	111	20	4	015705	72,33
25	50	126	25	5	015706	87,82
26	56	132	25	5	015709	116,25
30	63	139	25	5	015707	129,18
32	63	143	32	5	015708	142,11
35	63	143	32	6	015710	206,70
36	63	143	32	6	015711	236,83

FRAISES A CHANFREINER | HSSE-CO ULTIMATECUT

D1	ANGLE	HSS E		HSS TiAIN		HSS E *		HSSE RUnATEC *	
		CODE	PRIX € HT	CODE	PRIX € HT	CODE	PRIX € HT	CODE	PRIX € HT
4,30	90°	011860	13,03	011879	21,88				
4,80	90°			011880	21,88				
5,00	90°	011861	13,03	011881	21,88				
5,30	90°	011862	13,36	011882	22,72				
5,80	90°			011883	23,75				
6,00	90°	011863	13,36	011884	25,24				
6,30	90°	011864	13,36	011885	26,06	011904	41,50	011915	59,06
7,00	90°			011886	27,29				
7,30	90°			011887	28,43				
8,00	90°	011865	14,95	011888	28,57				
8,30	90°	011866	15,41	011889	29,47	011905	45,63	011916	65,39
9,40	90°			011890	31,46				
10,00	90°	011867	17,27	011891	34,67				
10,40	90°	011868	17,85	011892	35,32	011906	46,62	011917	66,96
11,50	90°	011869	19,45	011893	37,11				
12,40	90°	011870	19,64	011894	38,33	011907	55,68	011918	79,99
13,40	90°			011895	39,73				
15,00	90°	011871	21,64	011896	44,16	011908	58,47	011919	83,55
16,50	90°	011872	23,00	011897	47,19	011909	64,81	011920	60,60
19,00	90°	011873	32,93	011898	57,58	011910	72,50	011921	103,69
20,50	90°	011874	33,57	011899	63,89	011911	80,40	011922	115,55
23,00	90°	011875	41,85	011900	77,04	011912	88,11	011923	127,39
25,00	90°	011876	46,42	011901	86,36	011913	96,99	011924	139,26
28,00	90°	011877	65,03	011902	103,03				
31,00	90°	011878	65,03	011903	114,21	011914	123,24	011925	170,88



* La fraise à chanfreiner ULTIMATECUT est un outil haute performance pour un travail optimal : jusqu'à 30% de gain de temps, deux fois plus de chanfreins qu'avec les chanfreins standards et un résultat de chanfreinage optimal et lisse sur presque tous les matériaux.

Ceci est possible grâce à la fraise à chanfreiner de Ruko, avec sa géométrie d'arête de coupe unique, sa dépouille variable spécialement développée, ses rayons de transition et sa goujure extra-large



FRAISES A CHANFREINER | YT



**REMISE 20%
À DÉDUIRE**

D	D1	d	L	AP	M	Z	INSERT	SCREW	KEY	Articles	Prix tarif € HT
18	11	12	90	3		2	SD 06	C025045	T08P	MC 1218	140,08
25	19	16	100	3		3	SD 06	C025045	T08P	MC 1625	143,98
32	22	20	100	6		2	SD 09	C04011	T15P	MC 2032	155,88
45	32	32	110	6		3	SE 13T3	C03508	T10P	MC 3245	165,10
18	11	11	20	3	6	2	SD 06	C025045	T08P	HMC 18	132,30
25	19	15	30	3	8	3	SD 06	C025045	T08P	HMC 25	136,20
32	22	19	30	6	10	2	SD 09	C04011	T15P	HMC 32	147,71
45	32	31	40	6	16	3	SE 13T3	C03508	T10P	HMC 45	155,88

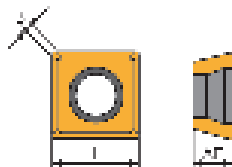

I	AE	B	Articles	Prix tarif € HT
6,00	2,30	1,0	SDET060208N ME B100	13,93
9,00	3,97	1,2	SDET09T308TN M B100	15,33
9,00	3,97	1,2	SDET09T308TN ME B100	15,33
13,40	3,97	1,5	SEHT13T3AFTN M B100	11,75
13,40	3,97	1,5	SEHT13T3AFTN ME B100	11,75

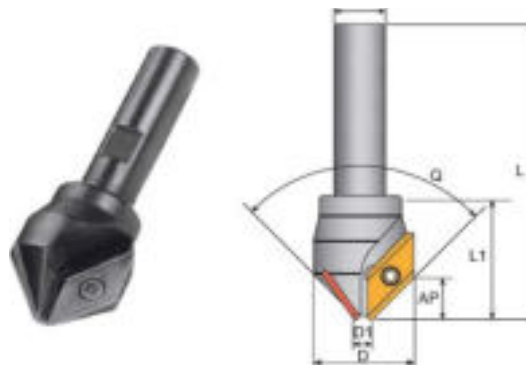

D1	D	d	L	AP	L1	Q	INSERT	SCREW	KEY	Articles	Prix tarif € HT
7,00	17,00	10,00	65,00	8,50	27,00	60°	XDGT120308	C03506	T10P	CI 17 60°	155,95
15,50	31,00	12,00	78,00	13,00	35,00	60°	XDGT19408	C04011	T15P	CI 31 60°	212,17
4,00	10,00	10,00	60,00	3,00	14,00	90°	ADGT060204	C01804	T06P	CI 12 90°	137,78
4,00	10,00	10,00	90,00	3,00	14,00	90°	ADGT060204	C01804	T06P	CI 12 90° L	142,44
5,50	22,00	10,00	65,00	8,00	27,00	90°	XDGT12308	C03506	T10P	CI 22 90°	155,95
15,00	36,00	12,00	78,00	10,00	38,00	90°	XDGT19408	C04011	T15P	CI 36 90°	223,85

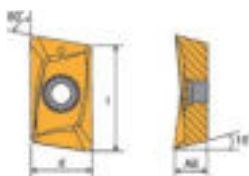

I	d	AE	Articles	Prix tarif € HT
12,00	8,50	3,18	XDGT120308TR ME C B100	25,73
19,00	10,60	4,76	XDGT190408TR ME B100	32,92
40,00	10,60	4,76	XDGT400408TR ME B100	66,77
6,95	4,05	24,00	ADGT060204TR ME C B100	21,56

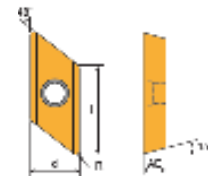

| TARIF ACTUEL EN VIGUEUR |

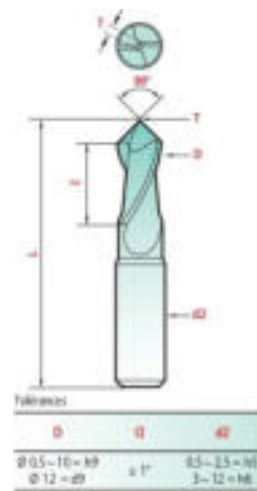
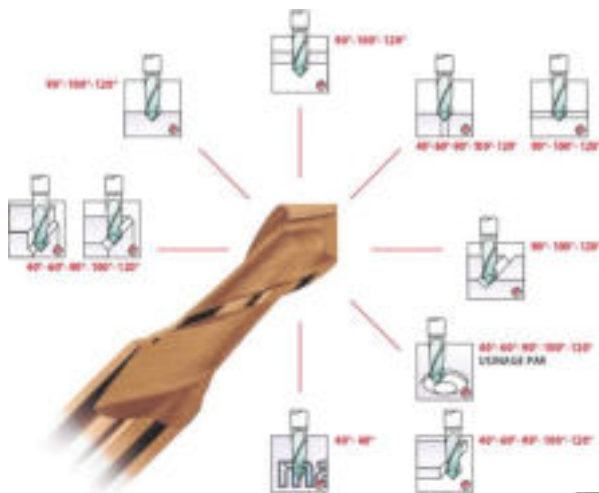

D	L	I	D2	T*	ANGLE	MULTI-V 8090	HARD'X 8090-H
0,50	39	1	3	0,05	90°	23,688	27,08
1,00	39	2	3	0,10	90°	23,688	27,08
1,50	39	3	3	0,15	90°	23,688	27,08
2,00	39	4	3	0,20	90°	23,688	27,08
2,50	39	5	3	0,25	90°	24,3705	32,37
3,00	50	6	4	0,30	90°	25,389	28,76
4,00	50	8	5	0,40	90°	26,229	29,61
5,00	50	10	6	0,50	90°	30,4605	33,84
6,00	60	12	8	0,60	90°	33,8415	37,22
8,00	70	16	10	0,80	90°	49,749	54,48
10,00	70	18	12	1,00	90°	61,929	69,37
12,00	70	20	12	1,20	90°	60,228	67,68

ÉBAVURAGE | POUR ACIERS, ALUMINIUM ET PLATIQUES

NNG 8150
1 MANCHE NOGAGRIP
10 LAMES FORTES Ø 3 / 2 S10



NNG 8150

14,52 €

NNG 9100
LE MANCHE NOGAGRIP-3
LES PORTES-LAMENETS AVEC
LES LAMES PIVOTANTES : N1 |
N2 | S10 | S20 | S30 | S150



NNG 9100

23,47 €



GAMME SB | SBL | 3T

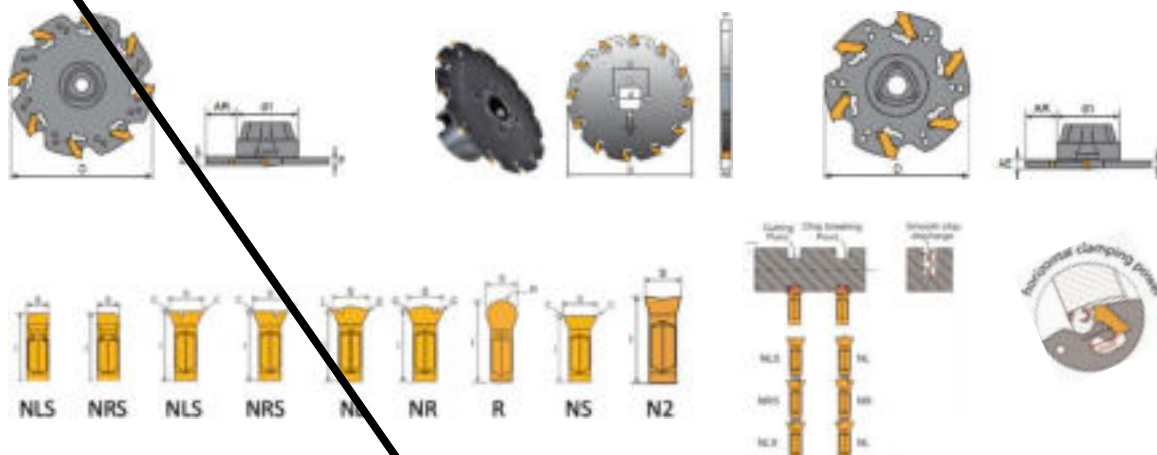

40 20 PLAQUETTES ACHETÉES = LE CORPS À 2,50€ DU MM*

* CLEF ET ENTRETOISE NON INCLUS

| OFFRE PROMOTIONNELLE VALABLE JUSQU'AU 30 JUIN 2022 SUR LES RÉFÉRENCES CI-DESSOUS |

SB
Dia. 50-160 mm
Epaisseur 1.4-5.5mm

SBL
Dia. 80-160mm
Epaisseur 1.4-5.5mm

3T16/3T25
Dia. 32-80mm
Epaisseur 1.4-8mm

PRIX PROMOTIONNELS NET HT - OFFRE VALABLE DANS LA LIMITE DES STOCKS DISPONIBLES - 31-12-2022*

* TECHMO SATECH NE PEUT GARANTIR LES PRIX SUR L'ANNÉE 2022

Nous nous donnons la possibilité de modifier les prix promotionnels en fonction des éventuels changements de prix de nos partenaires.

TECHMO

30 rue de Montaran
45400 FLEURY LES AUBRAIS
commercial.techmo@techmo.fr
☎ 02 38 61 48 10
☎ 02 38 84 39 63

TECHMO TOULOUSE

18 chemin de la Violette
31240 L'UNION
magasin.toulouse@techmo.fr
☎ 05 61 61 34 35
☎ 05 61 61 34 44

TECHMO BORDEAUX

9 rue Laplace
33700 MERIGNAC
magasin.toulouse@techmo.fr
☎ 05 61 61 34 35
☎ 05 61 61 34 44

SATECH

28 rue Alain Gerbault
72100 LE MANS
magasin@satech.fr
☎ 02 43 40 05 05
☎ 02 43 40 00 99