

# OPTI PROD 2022

PRIX PROMOTIONNELS NET HT  
OFFRE VALABLE JUSQU'AU 31-12-2022\*

SOUS RÉSERVE  
DE VARIATIONS  
TARIFAIRES

HAUSSE TARIFAIRE DE 5% AU 1<sup>ER</sup> OCTOBRE 2022



**TeCHMO**  
GROUPE **SaTeCH**  
Partenaire d'usage

\* TECHMO SATECH NE PEUT GARANTIR LES PRIX SUR L'ANNÉE 2022  
Nous nous donnons la possibilité de modifier les prix promotionnels en fonction des éventuels changements de prix de nos partenaires.



HSS 5% COBALT  
< 2,5 D



HSS 5% COBALT  
< 2,5 D



FRITTÉ  
< 3 D



FRITTÉ  
< 3 D

**A15S TIN**

**A70S TIN**

**P15 TIN**

**P70 TIN**

TOLÉRANCE  
ENTRÉE  
GOUJURE

6H  
B = 4 5 FILETS  
DROITE

6H  
C = 2 3 FILETS  
HÉLICOÏDALE 40°

6HX  
B = 4 5 FILETS  
DROITE

6HX  
C = 2 3 FILETS  
HÉLICOÏDALE 45°

		CODE	Prix promo € HT	CODE	Prix promo € HT	CODE	Prix promo € HT	CODE	Prix promo € HT
M2	x 0,40					042510	24,88		
M2,5	x 0,45					042511	24,88		
M3	x 0,50	041452	13,12	047504	13,12	042512	22,16	042528	24,48
M4	x 0,70	041453	13,12	047505	13,12	042513	22,16	042529	24,49
M5	x 0,80	041454	13,12	047506	13,12	042514	22,16	042530	24,49
M6	x 1,00	041455	13,12	047507	13,12	042515	22,62	042531	24,49
M8	x 1,25	041456	14,45	047508	14,45	042516	28,28	042532	31,21
M10	x 1,50	041457	17,87	047509	17,87	042517	35,26	042533	38,13
M12	x 1,75	041458	22,43	047510	22,43	042518	44,58	042534	48,83
M14	x 2,00	041459	37,83	047511	37,83	042519	59,42	042535	65,86
M16	x 2,00	041460	37,83	047512	37,83	042520	67,01	042536	75,71
M18	x 2,50					042521	92,42	042537	96,60
M20	x 2,50	041462	53,60	047515	53,60	042522	121,69	042538	125,55



HSS 5% COBALT



HSS 5% COBALT



HSS 5% COBALT

**A20S TiCN**

**A34 TIN**

**A61**

		CODE	Prix promo € HT	CODE	Prix promo € HT	CODE	Prix promo € HT
2	64 UNF	040919	29,69	040831	26,24	047429	24,28
3	56 UNF	040920	28,49	040832	25,19	047430	22,81
4	48 UNF	040921	27,73	040833	24,35	047431	21,88
5	44 UNF	040922	27,73	040834	24,35	047432	21,88
6	40 UNF	040923	26,66	040835	23,79	047433	20,85
8	36 UNF	040924	26,66	040836	23,79	047434	20,85
10	32 UNF	040925	27,73	040837	24,55	047435	21,88
12	28 UNF	040926	29,97	040838	26,46	047436	24,55
1/4	UNF	040927	29,97	040839	26,46	047437	24,55
5/16	UNF	040928	33,90	040840	30,16	047438	25,34
3/8	UNF	040929	36,63	040841	32,98	047439	25,90
7/16	UNF	040930	46,53	040842	41,67	047440	34,52
1/2	UNF	040931	48,12	040843	43,07	047441	35,58
9/16	UNF	040932	69,60	040844	61,82	047442	53,88
5/8	UNF	040933	68,70	040845	61,54	047443	51,08
3/4	UNF	040934	107,48	040846	97,80	047444	68,55
7/8	UNF	040935	134,51	040847	121,79	047445	88,34
1" 12	UNF	040936	207,47	040848	188,87	047447	130,22

# TARAUDS MACHINE VERGNANO | HSS 5% COLBALT - UNC



A19S TiCN

A60S TiCN

A33 TiN

			CODE	Prix promo € HT	CODE	Prix promo € HT	CODE	Prix promo € HT
2	56	UNC	040867	28,49	040849	28,76	040885	25,19
3	48	UNC	040868	27,44	040850	27,86	040886	24,35
4	40	UNC	040869	25,90	040851	26,10	040887	22,95
5	40	UNC	040870	25,90	040852	26,10	040888	22,95
6	32	UNC	040871	24,92	040853	25,26	040889	22,31
8	32	UNC	040872	24,92	040854	25,26	040890	22,31
10	24	UNC	040873	26,95	040855	27,17	040891	23,86
12	24	UNC	040874	27,30	040856	27,73	040892	24,21
1/4	20	UNC	040875	28,15	040857	29,97	040893	24,92
5/16	18	UNC	040876	31,99	040858	32,36	040894	28,71
3/8	16	UNC	040877	34,94	040859	35,36	040895	31,58
7/16	14	UNC	040878	43,64	040860	44,06	040896	39,15
1/2	13	UNC	040879	45,04	040861	45,60	040897	40,41
9/16	12	UNC	040880	65,39	040862	65,89	040898	58,38
5/8	11	UNC	040881	65,19	040863	65,81	040899	58,38
3/4	10	UNC	040882	101,31	040864	102,23	040900	92,61
7/8	9	UNC	040883	128,19	040865	129,46	040901	116,60
1"	8	UNC	040884	195,12	040866	195,12	040902	177,16

# TARAUDS MACHINE VERGNANO | HSS FRITTÉ - G



P18 TiH1

P59 TiH1

		CODE	Prix promo € HT	CODE	Prix promo € HT
1/8	28F	040807	44,62	040800	45,04
1/4	19F	040808	65,10	040801	65,66
3/8	19F	040809	79,84	040802	80,54
1/2	14F	040810	134,92	040803	136,67
5/8	14F	040811	160,80	040804	162,63
3/4	14F	040812	231,75	040805	233,56
1"11	11F	040813	332,98	040806	335,72

# TARAUDS À REFOULER VERGNANO | HSSK FRITTÉ - M



INOX | ACIER



TOLÉRANCE ENTRÉE	P80 TIN		P80N TIN		P80 V MAXX	
	6HX		6HX		6HX	
	C = 2	3 FILETS	C = 2	3 FILETS	C = 2	3 FILETS
	CODE	Prix promo € HT	CODE	Prix promo € HT	CODE	Prix promo € HT
M2 x 0,40	042592	33,34	042608	35,07	047841	37,20
M2,5 x 0,45	042593	30,87	042609	33,13	047842	35,13
M3 x 0,50	042594	27,62	042610	30,15	047843	31,48
M3,5 x 0,60	042595	27,62	042611	29,54	047844	31,48
M4 x 0,70	042596	28,15	042612	29,54	047845	31,48
M5 x 0,80	042597	27,62	042613	30,15	047846	31,48
M6 x 1,00	042598	27,62	042614	29,54	047847	31,48
M8 x 1,25	042599	34,80	042615	37,92	047848	39,65
M10 x 1,50	042600	44,04	042616	46,91	047849	50,11
M12 x 1,75	042601	52,10	042617	56,82	047850	59,29
M14 x 2,00	042602	69,99	042618	74,78	047851	79,84
M16 x 2,00	042603	87,10	042619	93,28	047852	99,13
M18 x 2,50			042620	145,91		
M20 x 2,50			042621	216,89		

# TARAUDS MACHINE BASS | INOX | ACIER | TITANE



INOX | ACIER | ALUMINIUM

**DOMINANT 1 VA45**



TARAUDS INOX   ACIER   ALU.	CODE	Prix promo € net HT
TAR BASS TH 16.6141 REV HL M3	043020	27,48
TAR BASS TH 16.6141 REV HL M4	043021	27,48
TAR BASS TH 16.6141 REV HL M5	043022	28,82
TAR BASS TH 16.6141 REV HL M6	043023	29,19
TAR BASS TH 16.6141 REV HL M8	043024	36,26
TAR BASS TH 16.6141 REV HL M10	043025	41,22
TAR BASS TH 16.6241 REV HL M12	043026	55,35
TAR BASS TH 16.6241 REV HL M14	043027	71,37
TAR BASS TH 16.6241 REV HL M16	043028	79,38
TAR BASS TH 16.6241 REV HL M20	043029	116,78

- HSSE PM
- ENTRÉE : C (2 -3)
- REVÊTEMENT : TiAlN
- GOUJURE : HÉLICOÏDALE 45°

**BASS**  
TECHNIK FÜR GEWINDE

INOX | ACIER | ALUMINIUM

VARIANT 1 VA



TARAUDS INOX   ACIER   ALU.	CODE	Prix promo € net HT
TAR BASS GUN 14.2311 REV HL M3	043035	24,61
TAR BASS GUN 14.2311 REV HL M4	043036	25,58
TAR BASS GUN 14.2311 REV HL M5	043037	27,29
TAR BASS GUN 14.2311 REV HL M6	043038	27,66
TAR BASS GUN 14.2311 REV HL M8	043039	34,16
TAR BASS GUN 14.2311 REVHL M10	043040	37,98
TAR BASS GUN 14.2411 REVHL M12	043041	52,29
TAR BASS GUN 14.2411 REVHL M16	043042	66,79
TAR BASS GUN 14.2411 REVHL M20	043043	103,04

- HSSE PM
- ENTRÉE : B (3,5 - 5)
- REVÊTEMENT : TIALN
- GOUJURE : DROITE

**BASS**  
TECHNIK FÜR GEWINDE

TITANE | INOX

AVANT 1 TIH13



TARAUDS TITANE   ACIER	CODE	Prix promo € net HT
TAR BASS TH 25.2131 M3 TICN	043050	29,00
TAR BASS TH 25.2131 M4 TICN	043051	29,77
TAR BASS TH 25.2131 M5 TICN	043052	31,87
TAR BASS TH 25.2131 M6 TICN	043053	32,06
TAR BASS TH 25.2131 M8 TICN	043054	38,93
TAR BASS TH 25.2131 M10 TICN	043055	45,03
TAR BASS TH 25.2231 M12 TICN	043056	61,82

- HSSE PM
- ENTRÉE : C (2 -3)
- REVÊTEMENT : TICN
- GOUJURE : HÉLICOÏDALE 13°

**BASS**  
TECHNIK FÜR GEWINDE

TITANE | INOX

VARIANT 1 TIH



TARAUDS TITANE   ACIER	CODE	Prix promo € net HT
TAR BASS GUN 25.2311 M3 TICN	043060	28,43
TAR BASS GUN 25.2311 M4 TICN	043061	29,19
TAR BASS GUN 25.2311 M5 TICN	043062	32,06
TAR BASS GUN 25.2311 M6 TICN	043063	33,21
TAR BASS GUN 25.2311 M8 TICN	043064	38,93
TAR BASS GUN 25.2311 M10 TICN	043065	46,19
TAR BASS GUN 25.2411 M12 TICN	043066	60,69

- HSSE PM
- ENTRÉE : B (3,5 - 5)
- REVÊTEMENT : TICN
- GOUJURE : DROITE

## VARIANT TIH TICN



TYPE	EXÉCUTION	PAS	DIAM	PAS	CODE	Prix promo € net HT
VARIANT 1 TIH	TICN	MJ	4	0,70	043069	59,88
VARIANT 1 TIH	TICN	MJ	5	0,80	043070	66,30
VARIANT 1 TIH	TICN	MJ	6	1,00	043071	68,01
VARIANT 1 TIH	TICN	MJ	8	1,25	043087	80,84
VARIANT 1 TIH	TICN	MJ	10	1,50	043088	95,80
VARIANT 1 TIH	TICN	UNJC	No6	32	043089	48,76
VARIANT 1 TIH	TICN	UNJC	No8	32	043072	49,19
VARIANT 1 TIH	TICN	UNJC	No10	24	043073	53,47
VARIANT 1 TIH	TICN	UNJC	1/4"	20	043074	55,60
VARIANT 1 TIH	TICN	UNJC	5/16"	18	043090	65,45
VARIANT 1 TIH	TICN	UNJC	3/8"	16	043091	76,98
VARIANT 1 TIH	TICN	UNJF	No6	40	043092	51,76
VARIANT 1 TIH	TICN	UNJF	No8	36	043075	52,18
VARIANT 1 TIH	TICN	UNJF	No10	32	043076	56,89
VARIANT 1 TIH	TICN	UNJF	1/4"	28	043077	59,46
VARIANT 1 TIH	TICN	UNJF	5/16"	24	043093	70,14
VARIANT 1 TIH	TICN	UNJF	3/8"	24	043094	82,12

## VARIANT TIH13 TICN



TYPE	EXÉCUTION	PAS	DIAM	PAS	CODE	Prix promo € net HT
AVANT 1 TIH13	TICN	MJ	4	0,70	043095	56,89
AVANT 1 TIH13	TICN	MJ	5	0,80	043078	62,44
AVANT 1 TIH13	TICN	MJ	6	1,00	043079	65,01
AVANT 1 TIH13	TICN	MJ	8	1,25	043080	77,84
AVANT 1 TIH13	TICN	MJ	10	1,50	043096	89,82
AVANT 1 TIH13	TICN	UNJC	No6	32	043097	46,19
AVANT 1 TIH13	TICN	UNJC	No8	32	043098	46,63
AVANT 1 TIH13	TICN	UNJC	No10	24	043081	50,91
AVANT 1 TIH13	TICN	UNJC	1/4"	20	043082	52,18
AVANT 1 TIH13	TICN	UNJC	5/16"	18	043083	62,44
AVANT 1 TIH13	TICN	UNJC	3/8"	16	043099	73,15
AVANT 1 TIH13	TICN	UNJF	No6	40	043100	49,19
AVANT 1 TIH13	TICN	UNJF	No8	36	043101	50,05
AVANT 1 TIH13	TICN	UNJF	No10	32	043084	52,18
AVANT 1 TIH13	TICN	UNJF	1/4"	28	043085	56,04
AVANT 1 TIH13	TICN	UNJF	5/16"	24	043086	66,30
AVANT 1 TIH13	TICN	UNJF	3/8"	24	043102	77,42

## VARIANT H VAP



TARAUDS INOX   ACIER	CODE	Prix promo € net HT
TAR BASS LP 882103 GUN VAP M3	043010	13,73
TAR BASS LP 882104 GUN VAP M4	043011	14,13
TAR BASS LP 882105 GUN VAP M5	043012	15,15
TAR BASS LP 882106 GUN VAP M6	043013	15,15
TAR BASS LP 882108 GUN VAP M8	043014	17,58
TAR BASS LP 882110 GUN VAP M10	043015	21,00
TAR BASS LP 882112 GUN VAP M12	043016	24,44
TAR BASS LP 882114 GUN VAP M14	043019	31,90
TAR BASS LP 882116 GUN VAP M16	043017	35,13
TAR BASS LP 882120 GUN VAP M20	043018	53,31

- HSSE PM
- ENTRÉE : B (3,5 - 5,4)
- REVÊTEMENT : VAP
- TROU BORGNE DÉBOUCHANT

## DOMINANT HZ38 VAP



TARAUDS INOX   ACIER	CODE	Prix promo € net HT
TAR BASS LP 884503 TH VAP M3	043001	14,13
TAR BASS LP 884504 TH VAP M4	043002	14,75
TAR BASS LP 884505 TH VAP M5	043003	15,75
TAR BASS LP 884506 TH VAP M6	043004	15,75
TAR BASS LP 884508 TH VAP M8	043005	18,17
TAR BASS LP 884510 TH VAP M10	043006	21,81
TAR BASS LP 884512 TH VAP M12	043007	25,25
TAR BASS LP 884514 TH VAP M14	043031	30,09
TAR BASS LP 884516 TH VAP M16	043008	36,35
TAR BASS LP 884520 TH VAP M20	043009	48,46

- HSSE PM
- ENTRÉE : C (2 - 3)
- REVÊTEMENT : VAP
- TROU BORGNE DÉBOUCHANT



INOX | ACIER | ALUMINIUM | FONTE



HSSE

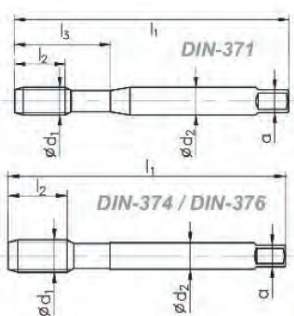

800X

C-R40-TN2

B-TN2



< 2,5 D



< 3 D

TYPE DE MATÉRIEL  
REVÊTEMENT  
ENTRÉE  
GOUJURE

M	P	L1	L2	L2 R40	L3	D2	a	
M3	0,50	56	10	5	18	3,5	2,7	2,50
M4	0,70	63	12	7	21	4,5	3,4	3,30
M5	0,80	70	14	8	25	6,00	4,90	4,20
M6	1,00	80	18	10	35	6,00	4,90	5,00
M8	1,25	90	20	13	35	8,00	6,20	6,80
M10	1,50	100	20	15	39	10,00	8,00	8,50

INDEX

HSSE  
TIALN + TiN  
C / 2 3F  
HÉLICOÏDALE 45°

HSSE  
TIALN + TiN  
B / 4 5F  
DROITE

C2 513X01		C2 113X01	
CODE	PRIX PROMO	CODE	PRIX PROMO
DIN 371			
045751	9,43	045362	9,03
045753	9,51	045364	9,09
045756	10,37	045367	9,95
045758	10,74	045369	10,31
045761	12,89	045372	12,34
045765	16,93	045376	16,25

M8x1	1,00	90	20	10	6,00	4,90	7,00	0083
M10x1	1,00	90	20	13	7,00	5,50	9,00	0103
M10x1,25	1,25	100	20	15	7,00	5,50	8,80	0104

C2 513X01		C2 113X01	
CODE	PRIX PROMO	CODE	PRIX PROMO
DIN 371			
045492	16,62	045486	15,88
045493	20,43	045487	19,55
045494	17,87	045488	16,70

M12	1,75	110	24	18	9,00	7,00	10,20	0120
M14	2,00	110	25	20	11,00	9,00	12,00	0140
M16	2,00	110	32	20	12,00	9,00	14,00	0160
M18	2,50	125	32	25	14,00	11,00	15,50	0180
M20	2,50	140	32	25	16,00	12,00	17,50	0200
M22	2,50	140	32	25	18,00	14,50	19,50	0220
M24	3,00	160	38	30	18,00	4,50	21,00	0240
M27	3,00	160	38	30	20,00	16,00	24,00	0270
M30	3,50	180	40	35	22,00	18,00	26,00	0300
M33	3,50	180	45	35	25,00	22,00	29,50	0330
M36	4,00	200	50	40	28,00	22,00	32,00	0360

D2 513X01		D2 113X01	
CODE	PRIX PROMO	CODE	PRIX PROMO
DIN 376			
045778	24,23	045389	22,52
045782	32,03	045393	29,72
045787	34,71	045399	32,19
045790	47,17	045402	43,71
045794	51,53	045406	47,86
045798	69,66	045410	64,49
045802	70,82	045414	66,00
045808	90,48	045420	88,26
045813	106,31	045425	103,71
045818	152,54	045430	148,53
045823	205,38	045435	199,86

M12x1,5	1,50	100	20	5	9,00	7,00	10,20	0125
M14x1,5	1,50	100	20	7	11,00	9,00	12,00	0145
M16x1,5	1,50	100	20	8	12,00	9,00	14,00	0162

D2 513X01		D2 113X01	
CODE	PRIX PROMO	CODE	PRIX PROMO
DIN 374			
045495	28,03	045489	25,99
045496	37,25	045490	34,46
045497	38,91	045491	36,04

# TARAUDS MACHINE FANAR | MASTER TAP - M



TITANE | INOX | ACIER | ALUMINIUM | FONTE - TARAUDS FRITTÉ



HSSE  
PM

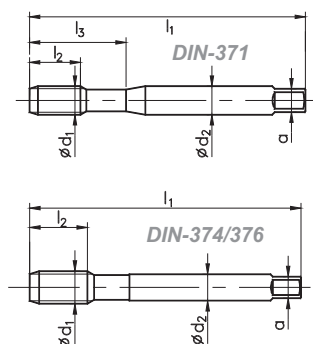

**MASTER TAP**

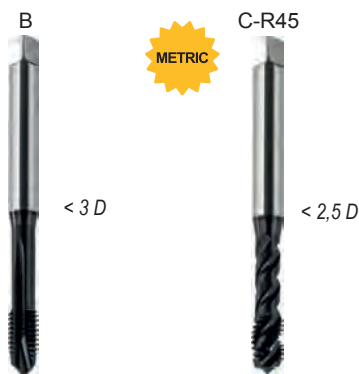

TOLÉRANCE  
REVÊTEMENT  
ENTRÉE  
GOUJURE

ISO2 (H6)  
TIALN  
B = 4 5 FILETS  
DROITE

ISO2 (H6)  
TIALN  
C = 2 3 FILETS  
HÉLICOÏDALE 45°

M	P	L1	L2	L3	D2	a		C4 118M01 CODE	PRIX PROMO	C4 528M01 CODE	PRIX PROMO		
2	0,4	45	8	12	2,8	2,1	1,6	045711	19,26	045719	21,40		
2,5	0,45	50	5	14	2,8	2,1	2,05	045712	19,26	045720	21,40		
3	0,50	56	5	18	3,5	2,1	2,50	045713	14,90	045721	16,56		
4	0,70	63	7	21	4,5	3,4	3,30	045714	15,68	045722	17,43		
5	0,80	70	8	25	6	4,9	4,20	045715	17,05	045723	18,95		
6	1,00	80	10	30	6	4,9	5,00	045716	17,63	045724	19,62		
8	1,25	90	13	35	8	6,2	6,80	045717	21,22	045725	23,57		
10	1,50	100	15	39	10	8	8,50	045718	27,86	045726	30,96		
								D4 118M31 DIN 376					D4 528M01 DIN 376
12	1,75	110	18		9	7	10,20	045727	41,08	045730	45,68		
14	2,00	110	20		11	9	12,00	045728	53,88	045731	59,85		
16	2,00	110	20		12	9	14,00	045729	57,91	045732	64,36		

# TARAUDS MACHINE FANAR | MASTER TAP - UNC



INOX | ACIER | ALUMINIUM | FONTE - TARAUDS FRITTÉ



HSSE  
PM

HL

DIN  
371

DIN  
376

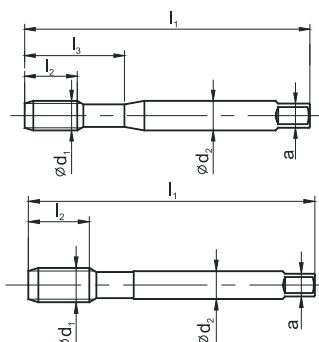

TYPE DE TROU  
QUALITÉ  
REVÊTEMENT  
ENTRÉE  
GOUJURE

MASTERTAP

B-HL

C-R45-HL



< 3 D



< 2,5 D

HSSE PM  
TIALN  
B / 4 5P  
DROITE

HSSE PM  
TIALN  
C / 2 3P  
HÉLICOÏDALE 45°

UNC	D1	1"/P	P	L1	L2	L3	D2	a		INDEX	C4 118M01 CODE PRIX PROMO DIN 371	C4 528M01 CODE PRIX PROMO DIN 371
No 2 56	2,184	56	0,455	45	10	13	2,8	2,1	1,85	4102	044055 11,94	044067 28,17
No 4 40	2,844	40	0,635	56	5	18	3,5	2,7	2,35	4104	045983 19,42	044068 22,15
No 5 40	3,175	40	0,635	56	7	8	3,5	2,7	2,65	4105	044056 18,69	044069 21,60
No 6 32	3,505	32	0,794	56	6	20	4,0	3,0	2,85	4106	045989 18,69	044070 21,60
No 8 32	4,165	32	0,794	63	7	21	4,5	3,4	3,50	4108	044057 16,82	044071 20,32
No 10 24	4,826	24	1,058	70	8	25	6,0	4,9	3,90	4110	044058 18,66	044072 20,24
No 12 24	5,486	24	1,058	80	10	30	6,0	4,9	4,50	4112	044059 19,55	044073 21,23
1/4 20	6,350	20	1,270	80	13	30	7,0	5,5	5,10	4127	044060 20,37	044074 26,48
5/16 18	7,938	18	1,411	90	13	35	8,0	6,0	6,60	4128	044061 22,78	044075 26,48
3/8 16	9,525	16	1,588	100	15	39	10,0	8,0	8,00	4129	044062 30,29	044076 33,20
7/16 14	11,112	14	1,814	100	15		8,0	6,2	9,40	4130	044063 37,38	044077 40,43
1/2 13	12,700	13	1,954	110	18		9,0	7,0	10,80	4131	044064 52,53	044078 56,33
9/16 12	14,288	12	2,117	110	20		11,0	9,0	12,20	4132	044065 51,92	044079 56,22
5/8 11	15,875	11	2,309	110	22		12,0	9,0	13,50	4133	044066 48,03	044080 51,87

D4 118M31 DIN 376	D4 528M01 DIN 376
044063 37,38	044077 40,43
044064 52,53	044078 56,33
044065 51,92	044079 56,22
044066 48,03	044080 51,87

# TARAUDS MACHINE FANAR | MASTER TAP - UNF



INOX | ACIER | ALUMINIUM | FONTE - TARAUDS FRITTÉ



HSSE  
PM

HL

DIN  
371

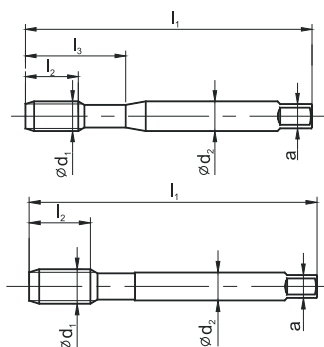

TYPE DE TROU  
QUALITÉ  
REVÊTEMENT  
ENTRÉE  
GOUJURE

**MASTERTAP**

B-HL

C-R45-HL



< 3 D



< 2,5 D

HSSE PM  
TIALN  
B / 4 5P  
DROITE

HSSE PM  
TIALN  
C / 2 3P  
HÉLICOÏDALE 45°

UNF	D1	1"/P	P	L1	L2	L3	D2	a		INDEX	C4 118M01		C4 528M01		
											CODE	PRIX PROMO	CODE	PRIX PROMO	
												DIN 371		DIN 371	
No 4	48	2,844	48	0,529	56	5	18	3,50	2,7	2,40	4204	044081	21,94	044094	25,02
No 5	44	3,175	44	0,557	56	7	18	3,50	2,7	2,70	4205	044082	21,13	044095	24,44
No 6	40	3,505	40	0,635	56	6	20	4,00	3,0	2,95	4206	044083	21,13	044096	24,44
No 8	36	4,185	36	0,705	63	7	21	4,50	3,4	3,50	4208	044084	18,98	044097	22,97
No 10	32	4,826	32	0,794	70	8	25	6,00	4,9	4,10	4210	044085	25,05	044098	27,25
No 12	28	5,486	28	0,907	80	10	30	6,00	4,9	4,60	4212	044086	22,08	044099	23,97
1/4	28	6,350	28	0,907	80	10	30	7,00	5,5	5,50	4227	044087	22,81	044100	30,45
5/16	24	7,938	24	1,058	90	13	35	8,00	6,0	6,90	4228	044088	25,54	044101	30,45
3/8	24	9,525	24	1,058	100	15	39	10,00	8,0	8,50	4229	044089	33,92	044102	38,19
												D4 118M01		D4 528M01	
												DIN 376		DIN 376	
7/16	20	11,112	20	1,270	100	15		8,00	6,2	9,90	4230	044090	41,85	044103	45,30
1/2	20	12,700	20	1,270	110	15		9,00	7,0	11,50	4231	044091	59,06	044104	64,41
9/16	18	14,288	18	1,411	100	15		11,00	9,0	12,90	4232	044092	59,67	044105	64,66
5/8	18	15,875	18	1,411	100	15		12,00	9,0	14,50	4233	044093	54,73	044106	59,11

# TARAUDS MACHINE FANAR | MASTER TAP - G



INOX | ACIER | ALUMINIUM | FONTE - TARAUDS FRITTÉ



HSSE  
PM

HL

DIN  
5156

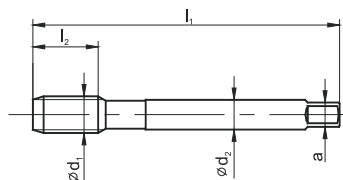

TYPE DE TROU  
QUALITÉ  
REVÊTEMENT  
ENTRÉE  
GOUJURE

MASTERTAP

B-HL

C-R45-HL



< 3 D



< 2,5 D



HSSE PM  
TIALN  
B / 4 5P  
DROITE

HSSE PM  
TIALN  
C / 2 3P  
HÉLICOÏDALE 45°

G	D1	1"/P	P	L1	L2	L3	D2	a		INDEX	D4 118M01		D4 528M01	
											CODE	PRIX PROMO	CODE	PRIX PROMO
											DIN 371		DIN 371	
G1/8	9,728	28	0,907	90	10		7	5,5	8,80	3123	044107	35,95	044115	38,83
G1/4	13,157	19	1,337	100	14		11	9,0	11,80	3127	044108	59,23	044116	64,27
G3/8	16,662	19	1,337	100	15		12	9,0	15,25	3129	044109	65,73	044117	70,53
G1/2	20,955	14	1,814	125	17		16	12,0	19,00	3131	044110	80,96	044118	87,17
G5/8	22,911	14	1,814	125	20		18	14,5	21,00	3133	044111	122,51	044119	132,37
G3/4	26,441	14	1,814	140	20		20	16,0	24,50	3135	044112	137,60	044120	148,48
G7/8	30,201	14	1,814	150	22		22	18,0	28,25	3137	044113	180,31	044121	194,59
G1	33,249	11	2,309	160	24		25	20,0	30,75	3139	044114	247,85	044122	268,85

## LUBRIFIANTS POUR TARAUDAGE

LUBRIFIANT	Articles	Code	Prix tarif € HT
RTD SPRAY LUBRIFIANT   AEROSOL 400 ML	R53011	049002	30,54
RTD PÂTE LUBRIFIANTE   POT 500G	R53023	049003	21,28
RTD LUBRIFIANT LIQUIDE   BURETTE 400G	R53072	049004	30,54
RTD 5 LITRES LIQUIDE	R53076	049006	287,49



# TARAUDS À REFOULER FANAR | INOX | ACIER



INOX | ACIER | ALUMINIUM

AVEC GOUJURE LUBRIFICATION

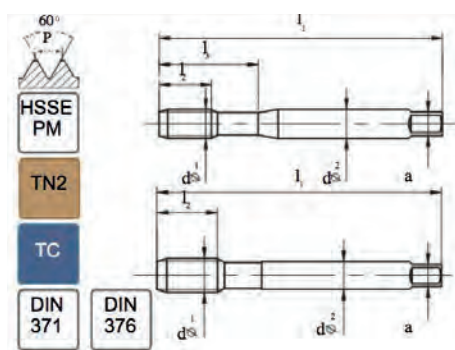

C-SR-TN2



C-SR-TC  
METRIC



QUALITÉ DU MATÉRIEL  
REVÊTEMENT  
ENTRÉE

M	P	L1	L2	L3	D2	a	INDEX	HSSE PM TIALN + TiN C / 2 3 P		HSSE PM TIALN + TiN C / 2 3 P	
								C4 923005 CODE	PRIX PROMO	C4 925005 CODE	PRIX PROMO
D1								DIN 371		DIN 371	
3	0,50	59	18	18	3,5	2,7	2,80	045735	15,19	045973	15,42
4	0,70	63	21	21	4,5	3,4	3,70	045736	15,19	045974	15,42
5	0,80	70	25	25	6	4,9	4,65	045737	16,75	045975	16,93
6	1,00	80	30	30	6	4,9	5,60	045738	17,61	045976	17,80
8	1,00	90	35	35	8	6,2	7,45	045739	21,45	045977	21,76
10	1,50	100	35	35	10	8	9,35	045740	26,21	045978	26,63

## BRAS DE TARAUDAGE PNEUMATIQUE

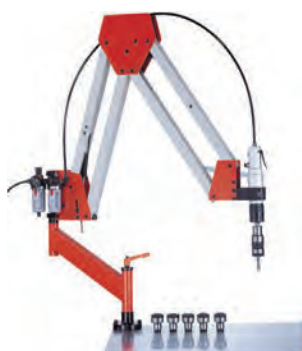

MODÈLE	MPD 12/II P0 130000 10312	MPD 16/II P0 130000 10316	MPD 22/II P0 130000 10322
CAP	M3 M12	M3 M16	M3 M22
N (TR/MIN)	400	300	120/300
SURFACE DE TRAVAIL	RMAX = 1900 MM		RMIN = 200 MM
POIDS (KG)	23	27	39
COUPLE <MAX. (NM)	32	12	100
DÉBIT AIR	840	840	935
ADAPTATEURS LIVRÉS	FZS19/M4,5,6,8,10,12	FZS19/M6,8,10,12,14,16	FZS19/M6,8,10,12,16,20
ADAPTATEURS EN OPTION	FZS19/M3	FZS19/M3,4,5 + FR31/19	FZS19/M3,4,5 + FR31/19 + FZS31/M14,18,22
CODE	045745	045746	045747
PRIX PROMO € NET HT	<del>2 946,25</del> 2 027,20	<del>4 426,37</del> 3 128,58	<del>6 192,73</del> 4 259,13

| LIVRÉ AVEC CLÉ DE SERRAGE LARDON ET BUTÉE LATÉRAL |

# SETS TARAUDS MACHINE



## SET DE TARAUD M4-M8

TYPE HRC60 C-HH-TC



Référence fournisseur	Qualité	Goujure	Type de trou	Revêtement	Entrée	Code	Prix € net HT
C9 135F01	CARBURE	DROITE		TiCN	D / 4 5P	045710	242,55

## TARAUDS CARBURE

TARAUD FANAR CARBURE TiCN HRC60	Code	Prix promo € HT
C9 135F01 0030 M3	045700	53,26
C9 135F01 0040 M4	045701	54,94
C9 135F01 0050 M5	045702	56,59
C9 135F01 0060 M6	045703	63,25
C9 135F01 0080 M8	045704	76,55

- HRC 60
- REVÊTEMENT : TiCN
- GOUJURE : DROITE

TARAUD VERGNANO CARBURE V MAXX H130	Code	Prix promo € HT
A000301309A1AV0 M3x0,5	042729	149,10
A000401309A1AV0 M4x0,7	042730	149,10
A000501309A1AV0 M5,08	042731	151,13
A000601309A1AV0 M6x1,00	042732	153,03
A000801309A1AV0 M8x1,25	042733	174,32
A001001309A1AV0 M10x1,5	042734	193,13
A001201309A1AV0 M12x1,75	042735	243,76

- H130
- REVÊTEMENT : V MAXX
- GOUJURE : DROITE

# BRAS DE TARAUDAGE ET PERÇAGE ÉLECTRIQUE



MODÈLE	BTE 1000-10T	BTE 1000-12T	BTE 1000-16T	BTE 1000-10PT
CAP	M3 M10	M3 M12	M3 M16	M3 M10
VITESSE	1 000 T/MIN	600 T/MIN	312 T/MIN	1 000 T/MIN
RAYON	1 100 MM	1 100 MM	1 100 MM	1 100 MM
DOUILLE	D19	D19	D19	D19 + MANDRIN AUTO SERRANT
MANDRIN	GR1	GR1	GR1	GR1
TÊTE	MULTIDIRECTIONNELLE	MULTIDIRECTIONNELLE	MULTIDIRECTIONNELLE	FIXE
PUISSANCE	600W 220V	600W 220V	600W 220V	600W 220V
CODE	0450000	0450001	0450002	0450003
PRIX € NET HT	1 433,25	1 501,50	1 617,00	1 751,40

PRIX PROMOTIONNELS NET HT - OFFRE VALABLE DANS LA LIMITE DES STOCKS DISPONIBLES - 31-12-2022\*

\* TECHMO SATECH NE PEUT GARANTIR LES PRIX SUR L'ANNÉE 2022

Nous nous donnons la possibilité de modifier les prix promotionnels en fonction des éventuels changements de prix de nos partenaires.

## TECHMO

30 rue de Montaran  
**45400 FLEURY LES AUBRAIS**  
commercial.techmo@techmo.fr  
☎ 02 38 61 48 10  
☎ 02 38 84 39 63

## TECHMO TOULOUSE

18 chemin de la Violette  
**31240 L'UNION**  
magasin.toulouse@techmo.fr  
☎ 05 61 61 34 35  
☎ 05 61 61 34 44

## TECHMO BORDEAUX

9 rue Laplace  
**33700 MERIGNAC**  
magasin.toulouse@techmo.fr  
☎ 05 61 61 34 35  
☎ 05 61 61 34 44

## SATECH

28 rue Alain Gerbault  
**72100 LE MANS**  
magasin@satech.fr  
☎ 02 43 40 05 05  
☎ 02 43 40 00 99